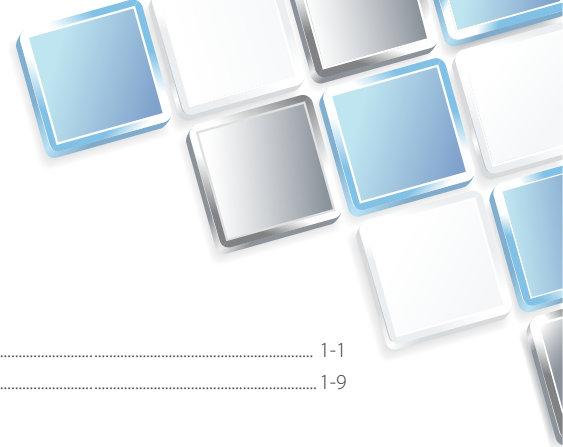

Table of Contents

2016



Chapter 1 Management Software

SmartView™ EMS	1-1
SmartView™ Central EMS	1-9

Chapter 2 iAccess™ Multi-Service Platform

In-Band Managed Multi-Service Platform.....	CH20, CH08 & CH04A	2-1
Network Management Controller.....	FRM220-NMC	2-3
Slide-in-Card Chassis for FRM220 Series.....	Standalone Chassis	2-6
Transponder (40G/16G/10G/4G/2.7G)		
NEW 40G Transponder (3R).....	FRM220-40G-1Q4S	2-8
16G Multi-rate Transponder (3R).....	FRM220-16G-3R	2-9
NEW 10G FEC Multi-rate Transponder.....	FRM220-10G-FEC	2-10
10G Multi-rate Transponder (3R) with Optical Line Protection.....	FRM220-10G-SXX	2-12
10G Multi-rate Transponder (3R)	FRM220-10G-SS	2-14
4 G Multi-rate Transponder (2R) with Optical Line Protection.....	FRM220-4G-3S	2-16
2.7G Multi-rate Transponder (3R) with Optical Line Protection.....	FRM220-2.7G-3S	2-18
EDFA		
NEW Optical Fiber Amplifiers	FRM220-OAB15	2-19
WDM		
DWDM Mux/DeMUX.....	FRM220-DWDM	2-20
CWDM Mux/DeMUX	FRM220-CWDM	2-22
Optical Protection Switch		
Fiber Optical Protection Switch (OPS Module Inside).....	FRM220-OPS52	2-24
NEW Fiber Optical Protection Switch (Splitter Inside).....	FRM220-OPS51	2-24
10G Converter		
10G Base-T to 10G Base-R SFP+ Media Converter	FRM220-10GC-TS	2-25
NID/EDD		
4x GbE, RJ45 + 4x Dual Rate L2+ OAM Managed Switch.....	FRM220-MSW404	2-26
2x GbE, RJ45 + 2x Dual Rate L2+ OAM Managed Switch.....	FRM220-MSW202	2-28
10/100/1000Base-T + 2x 100/1000/2500Base-X and 100/1000Base-X OAM Managed Switch.....	FRM220-MX210	2-30
Ethernet Switch		
2x 10/100/1000Base-T + 2x 100/1000Base-X SFP GbE Switch	FRM220A-1002ES	2-31
OAM/IP Managed 2x 10/100/1000Base-T + 2x 100/1000Base-X SFP GbE Switch.....	FRM220A-1000EAS/X	2-32
Media Converter		
10/100Base-TX to 100Base-FX Media Converter	FRM220-10/100	2-34
1000Base-X to 1000Base-X SFP Media Converter.....	FRM220-1000DS	2-35
1000Base-T to 1000Base-X SFP Media Converter	FRM220-1000TS	2-37
Web Smart OAM Managed 10/100/1000Base-T to 1000Base-X GbE Media Converter.....	FRM220-1000M	2-38
Web Smart OAM Managed 10/100/1000Base-T to 100/1000Base-X SFP GbE Media Converter.....	FRM220-1000MS	2-39
OAM/IP Managed 10/100/1000Base-T to 100/1000Base-X SFP GbE Media Converter	FRM220-1000EAS/X-1	2-40

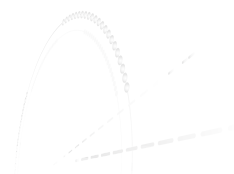

Table of Contents

2016



OAM/IP Managed 10/100Base-TX to 100Base-FX SFP FE Media Converter	FRM220-100EAS/X-1	2-41
In-Band Management 10/100Base-TX to 100Base-FX FE/SFP FE Media Converter.....	FRM220-10/100i	2-42
Dual Channels 10/100Base-TX to 100Base-FX In-Band Managed Converter	FRM220-10/100iS-2	2-43
Voice over Fiber		
4x FXO over Fiber.....	FRM220-FXO-4	2-44
4x FXS over Fiber.....	FRM220-FXS-4	2-44
FXO/FXS over Fiber.....	FRM220-FXO/FXS	2-45
Inverse Mux		
Ethernet over Bonded E1 NTU	FRM220A-iMux	2-46
Fiber Multiplexer		
8x E1/T1 + GbE Fiber Multiplexer	FRM220-GFOM08	2-48
4x E1/T1 + GbE Fiber Multiplexer	FRM220-GFOM04	2-49
4x E1/T1 + FE Fiber Multiplexer	FRM220-FOM04	2-50
E1/T1 + FE Fiber Multiplexer.....	FRM220-FOM01	2-51
Fiber Converters (DS3/E3, Serial)		
DS3/E3 over Fiber	FRM220-DS3/E3	2-52
RS232/485 over Fiber	FRM220-Serial	2-53
E1/T1 Cross Rate Converter		
E1/T1 Cross Rate Converter	FRM220-FTEC	2-54
E1/T1 DSU/CSU		
E1 to DATA.....	FRM220-E1/DATA	2-55
Ethernet over E1 Converters		
Ethernet Bridge over E1	FRM220A-Eoe1	2-56
Fiber Modem (E1/T1, Data, Ethernet)		
E1/T1 over Fiber.....	FRM220-E1/T1	2-57
RS232/530/V35 over Fiber.....	FRM220-DATA	2-58
Ethernet over E1 Fiber	FRM220-ET100	2-59

Chapter 3 SFP Patching Hub & Simple Media Converter

SFP Patching Hub

20x 100/1000Base-T to 20x 100/1000Base-X SFP Patching Hub.....	PHB-200M, PHB-200	3-1
--	-------------------	-----

FMC Series

Converter Chassis

Simple Converter Chassis.....	FMC-CH17	3-2
-------------------------------	----------	-----

Non-managed Converter

10/100/1000Base-T to 1000Base-X SFP Media Converter	FMC-1000S	3-3
10/100Base-TX to 100Base-FX Media Converter.....	FMC-10/100	3-4

Managed Converter

10/100/1000Base-T to 1000Base-X Web Smart OAM Managed Converter.....	FMC-1000M	3-5
10/100/1000Base-T to 100/1000Base-X SFP Web Smart OAM Managed Converter.....	FMC-1000MS	3-6
10/100Base-TX to 100Base-FX In-Band Managed Converter.....	FMC-10/100i	3-7

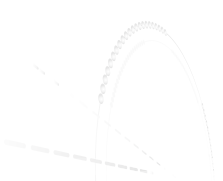

Table of Contents 2016



Chapter 4 L2+ Ethernet Switch

NEW 24x 100/1000Base-X SFP + 4x GbE (RJ-45) with 4x 10G Base-X Dual Speed SFP+	MSW-4428X	4-1
24x GbE, SFP + 4x 10GE (SFP+) L2+ Carrier Ethernet Switch with SyncE.....	MSW-4424S	4-3
24x GbE, SFP + 4x 10GE (SFP+) L2+ Carrier Ethernet Switch	MSW-4424A	4-5
20x GbE, SFP + 4x GbE Combo + 4x 10GE (SFP+) L2+ Managed Carrier Ethernet Switch with SyncE.....	MSW-4424CS	4-7
20x GbE, SFP + 4x GbE Combo + 4x 10GE (SFP+) L2+ Managed Carrier Ethernet Switch.....	MSW-4424C	4-9
24x GbE, SFP + 4x GbE RJ45 + 4x 1G/10G, SFP+ L2+ Managed Ethernet Switch	GSW-3424FM	4-11
20x GbE, SFP + 4x GbE Combo (SFP or RJ45) L2+ Managed Ethernet Switch.....	GSW-3420FM	4-13
24x GbE, RJ45 + 4x GbE Combo (SFP or RJ45) L2+ Managed Switch.....	GSW-3424M1	4-15
16x GbE, RJ45 + 2x GbE, SFP L2+ Managed Switch.....	GSW-3216M1	4-17
8x GbE, RJ45 + 2x GbE, SFP L2+ Managed Switch.....	GSW-3208M2	4-19
NID/EDD		
4x GbE, RJ45 + 4x Dual Rate SFP L2+ Carrier Ethernet Switch with SyncE.....	MSW-404SE	4-21
4x GbE, RJ45 + 4x Dual Rate SFP L2+ Carrier Ethernet Switch	MSW-404	4-23
2x GbE, RJ45 + 2x Dual Rate SFP L2+ Carrier Ethernet Switch	MSW-202	4-25
CPE Switch		
8x GbE, RJ45 + 2x Dual Rate SFP L2+ Managed Switch w/Cable Tray.....	GSW-2008MS	4-27
5x GbE, RJ45 + 1x Dual Rate SFP L2+ Managed Switch w/Cable Tray.....	GSW-1005MS	4-29
4x FE, RJ45 + 1x FE, Fiber Switch.....	FSW-2104	4-31
Fiber IAD		
Gigabit Fiber IAD with IEEE 802.11ac WiFi.....	GW-732FW	4-32
Gigabit Fiber IAD with IEEE 802.11n WiFi.....	GW-532FW	4-34

Chapter 5 PoE Switch/Converter/Injector

PoE Switch		
16x GbE, RJ45 + 2 Dual Rate SFP L2+ Managed PoE Switch	GSW-3216MP	5-1
8x GbE, RJ45 + 2 Dual Rate SFP L2+ Managed PoE Switch.....	GSW-3208MP	5-3
PoE Media Converter		
10/100/1000Base-T to 1000/1000Base-X SFP with PoE+ (PSE) Fiber Converter	FMC-1000S-PH	5-5
100/1000Base-T to 1000Base-X SFP PoE PSE Converter with AC Power built-in.....	IFC-1000PSE	5-7
100/1000Base-T to 1000Base-X SFP PoE PSE Converter with AC Adapt	IFC-1000PSE/A	5-7
10/100Base-TX to 100Base-FX PoE PD Media Converter.....	IFC-100PD	5-8
PoE Injector		
Gigabit Ethernet IEEE802.3af/at High Power PoE Injector	INJ-G30	5-9

Chapter 6 Fiber Optical Multiplexer

Modularized 16E1/T1 + 4x GbE Managed Fiber Multiplexer.....	FMUX1001	6-1
Modularized 16E1/T1 + 4x FE Managed Fiber Multiplexer.....	FMUX101	6-2
16 or 8x E1/T1 + 4x GbE, Managed Fiber Multiplexer.....	FMUX1600/FMUX800	6-4
16 or 8x E1/T1 + 4x FE, Managed Fiber Multiplexer.....	FMUX160/FMUX80	6-5
4E1/T1 + 3x FE Fiber Multiplexer.....	FMUX04E	6-7
4E1/T1 Fiber Multiplexer	FMUX04	6-8

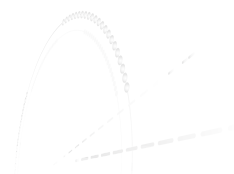

Table of Contents 2016



Chapter 7 SFP Transceiver

SFP Transceiver.....	7-1
----------------------	-----

Chapter 8 LAN Extender

LAN Extender with 4 Ports Gigabit Ethernet	VDTU2A-404	8-1
LAN Extender with 4 Ports Fast Ethernet	VDTU2A-304	8-2
LAN Extender with 1 Port Fast Ethernet.....	VDTU2A-301	8-3

Chapter 9 EFM Modem

G.SHDSL bis EFM Modem with 4 Ports Ethernet.....	EFM10, EFM20 , EFM40	9-1
--	----------------------	-----

Chapter 10 VDSL2 DSLAM/Modem

VDSL2 DSLAM

24x VDSL2 IP DSLAM.....	VDSM2-1524	10-1
8x VDSL2 IP DSLAM	VDSM2-1008	10-2

VDSL2 Bridge/Router

VDSL2 802.11n Wireless Router.....	VDTU2-R240W	10-3
VDSL2 Router with 4 Ports Ethernet	VDTU2-R140	10-5
VDSL2 Ethernet Bridge.....	VDTU2-B110	10-6

Chapter 11 TDM Series

STM1/E1 Access Multiplexers

STM1/E1, Data, Ethernet, Voice Managed Multiplexer (4.5U).....	iSAP5100	11-1
E1, Data, Ethernet, Voice Managed Multiplexer (2U).....	iSAP2000	11-3
STM1/E1 Multiplexer.....	iSAP1000	11-5

E1 Access Unit /Multiplexers

4x E1 Multiplexer.....	ERM-MUX-Plus	11-7
E1 Multiplexer	ETU02-MUX	11-9
Single Modular Port E1 CSU/DSU w/ LCD and SNMP.....	ETU01A	11-10
Single Modular Port E1 CSU/DSU.....	ETU011	11-11
Single V.35 Port E1 CSU/DSU	ETU01-Plus	11-13
Ethernet over E1 with SNMP Management.....	Eoe1A	11-14

Ethernet Bridge

Ethernet to WAN (V.35/RS530/449/232/X.21) Bridge.....	ET100A	11-15
---	--------	-------

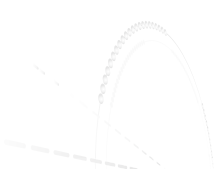

Table of Contents

2016



Chapter 12 TDM over IP

E1/V.35 over Ethernet Access Unit.....	IPM-1SE/V35	12-1
E1 over Ethernet.....	IPM-1E1	12-2
4x E1 over Ethernet.....	IPM-4E1	12-2
8x E1 over Ethernet.....	IPM-8E1	12-3
16x E1 over Ethernet.....	IPM-16E1	12-3

Chapter 13 IP Device Server

RS232 Serial Server.....	STE100A-232	13-1
RS485/232 Serial Server.....	STE100A-Serial	13-1

Appendix

FRM220 Standalone Selection Table.....	P.171
FRM220 Slide-in Card vs Standalone Chassis Compatible Table.....	P.172

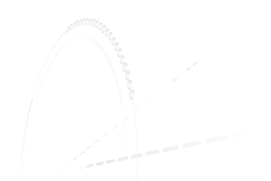



EMS SmartView™

Superior Design with Real-Time Monitor and Control

Fault Management

- Trap Collection
- Active Alarm
- Alarms sent by E-mail & SMS

Configuration Management

- Network Topology
- Network Element Configuration
- Network Element Discovery

Accounting Management

- Location, status and serial numbers of all assets can be managed and exported

Performance Management

- Device Performance is plotted over time using standard PM data such as ES UAS, etc.

Security Management

- User Privilege
- User Activity



SmartView™ EMS Element Management System

- Centralized Device Management Platform
- Real-time visual representations and processing of alarms
- Easy and User-Friendly Operation Interface
- Long term event storage (up to 1 year)

Main Feature

- Main Functions (**FCAPS**): **F**ault, **C**onfiguration, **A**ccounting, **P**erformance and **S**ecurity Management
- Remote access control for efficient configuration
- Traffic / Performance monitoring and management
- Alarm Trap and event log management
- Auto Discovery and Device Viewer
- Allow up to 25 administrators to login

Network Scheme Diagram

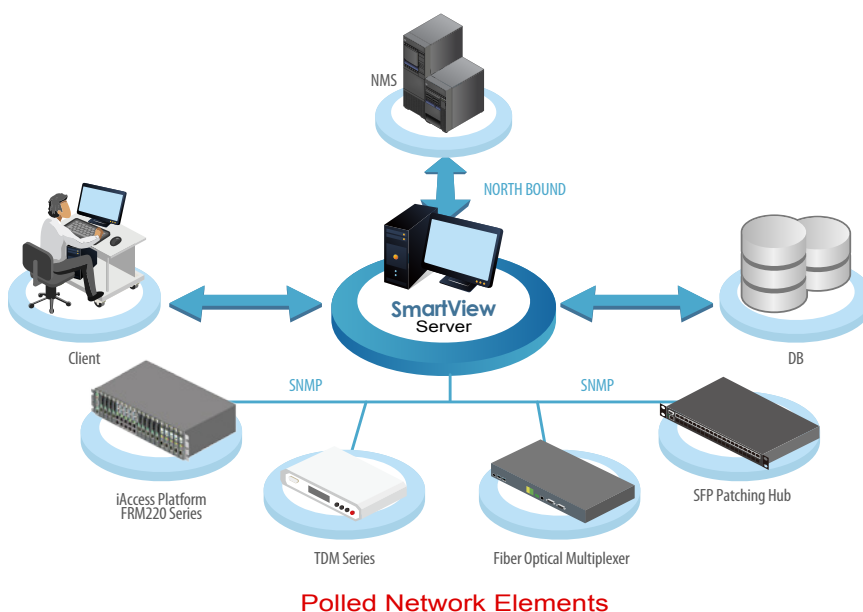

- User-Friendly Operation Interface
- Robust Client / Server architecture
- Network Monitoring and Management
- Database for persistent event storage
- Security Access Management

Agents

All of CTC Union's SNMP enabled products, such as FRM220 platform, FMUX series of fiber multiplexers and TDM are manageable by CTC Union SmartView™ EMS management Platform.

SmartView™ Server

The server handles connection with the network devices using SNMP protocol, and is responsible for communication of requests from management clients. SmartView™ Server collects the information data from specific SNMP agents, stores the information into a persistent database and updates that information to the management clients.

Microsoft® SQL Server for Persistent Storage

SQL Server is the place where the SmartView™ collected data, such as alarms, traps and user actions is stored for long term retrieval. SmartView™ requires Microsoft® SQL Server and is compatible with SQL Server 2005, SQL 2005 Express, SQL 2008 Server, SQL 2008 Express, SQL 2012 Server and SQL 2012 Express. (The EMS installer will install the free version Microsoft® SQL 2008 Express by default.)

Workstation-Clients

Management clients are provided with the JAVA applet GUI to monitor and control the agents at far end. They also receive the Alarm and Traps from the corresponding SNMP Agents. Multiple workstations are allowed, with a maximum of 25 concurrent logged in users.

Features at a Glance

- Fault Management

Trap Collection

All traps will be stored in SQL database. When an SNMP agent experiences an abnormal condition it will send an SNMP trap message to SmartView™ which then receives the message, and records it in the database. Depending on preset conditions, SmartView™ may sound an audible alarm, send an email or SMS alert message or just simply flash the trap message on the administrative console screen.

No.	Ack	Time	Device	Address	Message
1	✓	2013-10-31 16:43:25	FRM220-44	10.1.1.44	Chassis1_Slot06_Local: Fiber Link Down.
2	✓	2013-10-31 16:43:25	FRM220-44	10.1.1.44	Chassis1_Slot07_Local: Fiber Link Down.
3	✓	2013-10-31 16:43:25	FRM220-44	10.1.1.44	Chassis1_Slot10_Local: Fiber1 Link Down.
4	✓	2013-10-31 16:43:25	FRM220-44	10.1.1.44	Chassis1_Slot10_Local: Fiber2 Link Down.
5	✓	2013-10-31 16:43:25	FRM220-44	10.1.1.44	Chassis1_Slot11_Local: Fiber Link Down.
6	✓	2013-10-31 16:43:25	FRM220-44	10.1.1.44	Chassis1_Slot11_Local: UTP Link Down.
7	✓	2013-10-31 16:43:26	FRM220-44	10.1.1.44	Chassis1_Slot12_Local: Fiber Link Down.
8	✓	2013-10-31 16:43:26	FRM220-44	10.1.1.44	Chassis1_Slot12_Local: UTP Link Down.
9	✓	2013-10-31 16:43:26	FRM220-44	10.1.1.44	Chassis1_Slot13_Local: Fiber1 Link Down.
10	✓	2013-10-31 16:43:26	FRM220-44	10.1.1.44	Chassis1_Slot13_Local: Fiber2 Link Down.
11	▲	2013-10-31 16:43:26	FRM220-44	10.1.1.44	Chassis1_Slot13_Local: Fiber3 Link Down.
12	▲	2013-10-31 16:43:26	FRM220-44	10.1.1.44	Chassis1_Slot15_Local: UTP Link Down.
13	▲	2013-10-31 16:43:26	FRM220-44	10.1.1.44	Chassis1_Slot15_Local: E1 Signal Loss.
14	▲	2013-10-31 16:43:26	FRM220-44	10.1.1.44	Chassis1_Slot16_Local: UTP Link Down.
15	▲	2013-10-31 16:43:26	FRM220-44	10.1.1.44	Chassis1_Slot16_Local: E1 Signal Loss.
16	▲	2013-10-31 16:43:26	FRM220-44	10.1.1.44	Chassis1_Slot17_Local: Fiber Link Down.
17	▲	2013-10-31 16:43:26	FRM220-44	10.1.1.44	Chassis1_Slot17_Local: UTP Link Down.
18	▲	2013-10-31 16:43:26	FRM220-44	10.1.1.44	Chassis1_Slot18_Local: Fiber Link Down.
19	▲	2013-10-31 16:43:26	FRM220-44	10.1.1.44	Chassis1_Slot18_Local: UTP Link Down.
20	▲	2013-10-31 16:43:26	FRM220-44	10.1.1.44	Chassis1_Slot19_Local: Fiber Link Down.
21	▲	2013-10-31 16:43:26	FRM220-44	10.1.1.44	Chassis1_Slot19_Local: UTP Link Down.
22	▲	2013-10-31 16:43:26	FRM220-44	10.1.1.44	Chassis1_Slot20_Local: Fiber Link Down.
23	▲	2013-10-31 16:43:27	FRM220-44	10.1.1.44	Chassis1_Slot20_Local: UTP Link Down.
24	▲	2013-10-31 16:43:27	FRM220-44	10.1.1.44	Chassis1_Slot02_Local: Card FRM220A-1000EAS/X Found.
25	▲	2013-10-31 16:43:27	FRM220-44	10.1.1.44	Chassis1_Slot03_Local: Card FRM220A-1000EAS/X Found.
26	▲	2013-10-31 16:43:27	FRM220-44	10.1.1.44	Chassis1_Slot04_Local: Card FRM220A-1000EAS/X Found.
27	▲	2013-10-31 16:43:39	FRM220-44	10.1.1.44	Chassis1_Slot05_Local: Card FRM220A-1000EAS/X Found.
28	▲	2013-10-31 16:44:10	FRM220-44	10.1.1.44	Chassis1_Slot02_Local: Fiber1 Link Down.
29	▲	2013-10-31 16:44:10	FRM220-44	10.1.1.44	Chassis1_Slot02_Local: Fiber2 Link Down.

Trap Messages

Active Alarm

SmartView™ continuously polls all network devices under its management and will visually display all alarm conditions found. Alarms will be categorized as Major, Minor or Warning, depending on severity. Although alarms may be acknowledged, they remain actively displayed on the alarm page until there is no longer an alarm condition.

No.	Ack	Time	Device	Address	Location	Message	Severity
1	✓	2013-10-31 16:40:28	FMUX04E-43	10.1.1.43	Local	Fiber2 port has no link.	Warning
2	✓	2013-10-31 16:48:28	FMUX04E-43	10.1.1.43	Local	E1 channel CH1 inactive.	Warning
3	✓	2013-10-31 16:48:28	FMUX04E-43	10.1.1.43	Local	E1 channel CH2 inactive.	Warning
4	✓	2013-10-31 16:48:28	FMUX04E-43	10.1.1.43	Local	E1 channel CH3 inactive.	Warning
5	✓	2013-10-31 16:48:28	FMUX04E-43	10.1.1.43	Local	E1 channel CH4 inactive.	Warning
6	✓	2013-10-31 16:48:28	FMUX04E-43	10.1.1.43	Local	RS232 port inactive.	Warning
7	✓	2013-10-31 16:48:28	FMUX04E-43	10.1.1.43	Local	LAN2 port inactive.	Warning
8	▲	2013-10-31 16:49:30	FMUX04E-43	10.1.1.43	Local	LAN3 port inactive.	Warning
9	▲	2013-10-31 17:06:01	FMUX04E-43	10.1.1.43	Remote	E5 error (Error seconds).	Minor
10	▲	2013-10-31 17:04:36	FMUX04E-43	10.1.1.43	Remote	Fiber2 port has no link.	Warning
11	▲	2013-10-31 17:04:36	FMUX04E-43	10.1.1.43	Remote	E1 channel CH1 inactive.	Warning
12	▲	2013-10-31 17:04:36	FMUX04E-43	10.1.1.43	Remote	E1 channel CH2 inactive.	Warning
13	▲	2013-10-31 17:04:36	FMUX04E-43	10.1.1.43	Remote	E1 channel CH3 inactive.	Warning
14	▲	2013-10-31 17:04:36	FMUX04E-43	10.1.1.43	Remote	E1 channel CH4 inactive.	Warning
15	▲	2013-10-31 17:04:36	FMUX04E-43	10.1.1.43	Remote	RS232 port inactive.	Warning
16	▲	2013-10-31 17:04:36	FMUX04E-43	10.1.1.43	Remote	LAN1 port inactive.	Warning
17	▲	2013-10-31 17:04:36	FMUX04E-43	10.1.1.43	Remote	LAN2 port inactive.	Warning
18	▲	2013-10-31 17:04:36	FMUX04E-43	10.1.1.43	Remote	LAN3 port inactive.	Warning
19	▲	2013-10-31 17:04:36	FMUX04E-43	10.1.1.43	Remote	Phone port inactive.	Warning
20	▲	2013-10-31 16:43:25	FRM220-44	10.1.1.44	Rack 1 Slot 1 Local	Power1 is not working or not installed.	Minor
21	▲	2013-10-31 16:43:25	FRM220-44	10.1.1.44	Rack 1 Slot 1 Local	Fan1 is not working or not installed.	Minor
22	▲	2013-10-31 16:43:25	FRM220-44	10.1.1.44	Rack 1 Slot 1 Local	Alarm1 setting is in alarm.	Minor
23	▲	2013-10-31 16:43:25	FRM220-44	10.1.1.44	Rack 1 Slot 1 Local	Alarm2 setting is in alarm.	Minor
24	▲	2013-10-31 16:43:58	FRM220-44	10.1.1.44	Rack 1 Slot 2 Local	Fiber1 port has no link.	Major
25	▲	2013-10-31 16:43:58	FRM220-44	10.1.1.44	Rack 1 Slot 2 Local	Fiber2 port has no link.	Major
26	▲	2013-10-31 16:43:58	FRM220-44	10.1.1.44	Rack 1 Slot 2 Local	UTP3 port has no link.	Major
27	▲	2013-10-31 16:43:58	FRM220-44	10.1.1.44	Rack 1 Slot 2 Local	UTP4 port has no link.	Major
28	▲	2013-10-31 16:43:58	FRM220-44	10.1.1.44	Rack 1 Slot 3 Local	Fiber1 port has no link.	Major
29	▲	2013-10-31 16:43:58	FRM220-44	10.1.1.44	Rack 1 Slot 3 Local	Fiber2 port has no link.	Major

Active Warnings

Alarms sent by E-mail & SMS

The SmartView™ is capable of sending emails and or SMS text messages to selected administrators when critical alarms occur. Prompt notification of system problems aid in getting problems in the network devices fixed in the shortest time possible.

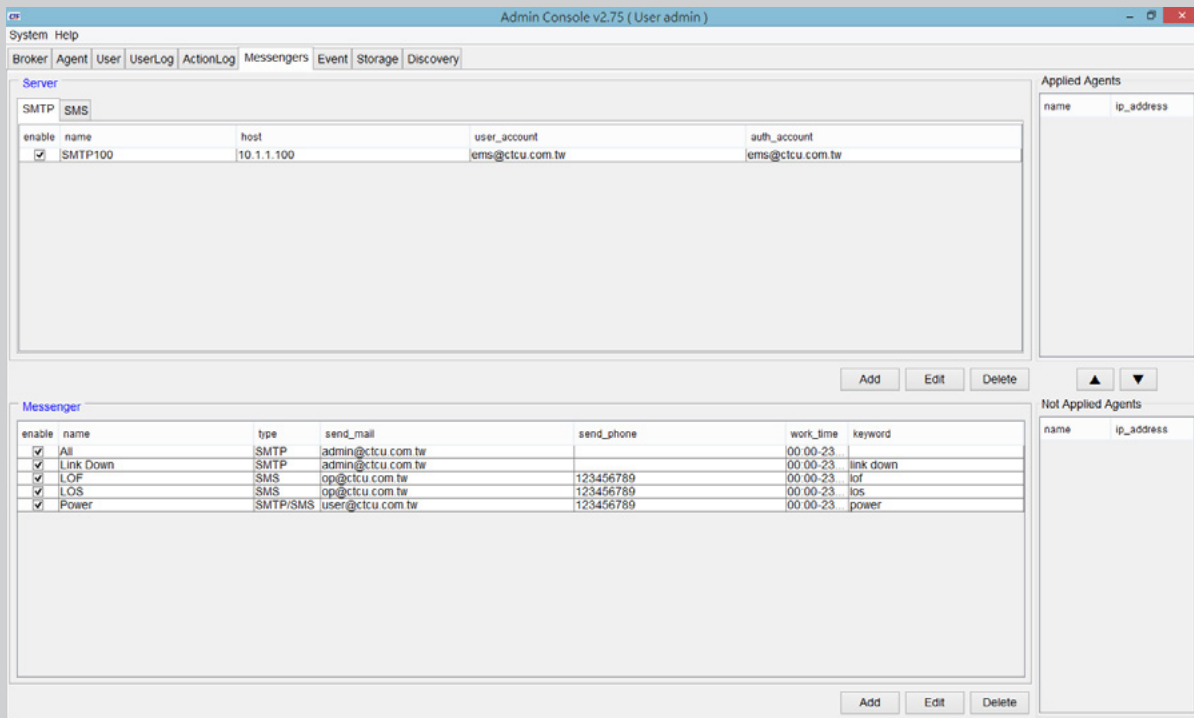

Alarms Sent by Email & SMS

• Configuration Management

Network Topology

User can load maps to SQL server, load maps from SQL server or delete attached maps. Download procedure is very simple. Map area may be used to layout any objects from Root and Node panel.

Using drag-and-drop, put any object to map area. Any label or network element location name may be added to object. Objects in red color indicate some alarm condition is present in the device. Right clicking an object brings a popup window to select Telnet or http management of the device directly.

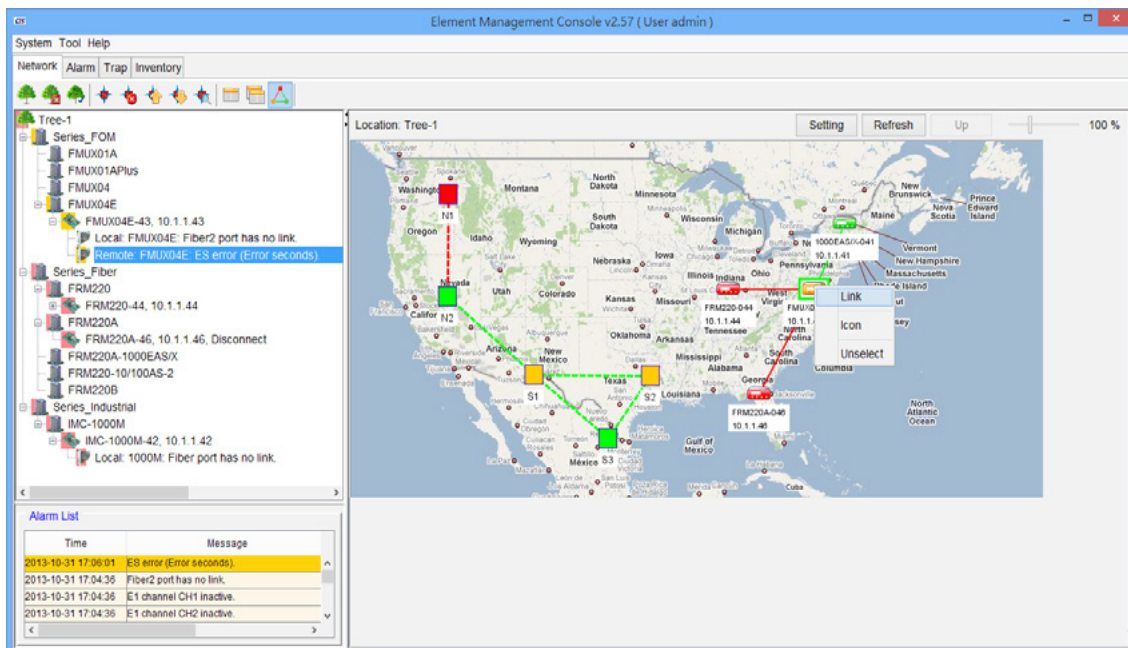

Network Topology

Network Element Configuration

SmartView™ is able to provide a single point of configuration for the network device elements. Most settings only require mouse clicks and by using a tab format, most scrolling is eliminated. Current settings and status are displayed along with hardware and firmware versions for each element.

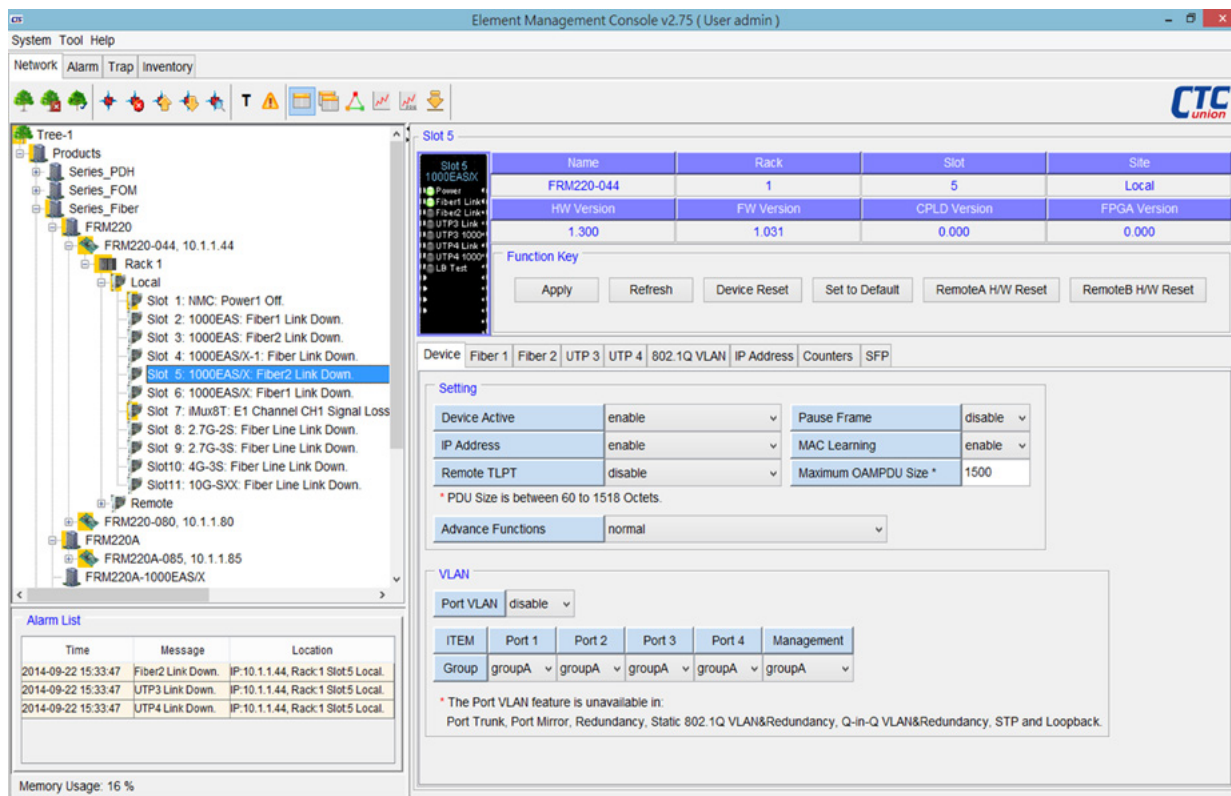

Network Element Configuration

Network Element Discovery

SmartView™ has a tool for automatically discovering SNMP agents on the network. Simply enter an IP address range and the discovery program will ping every IP address looking for SNMP agents. Once discovered, the agents can be selected and brought into the broker for polling.

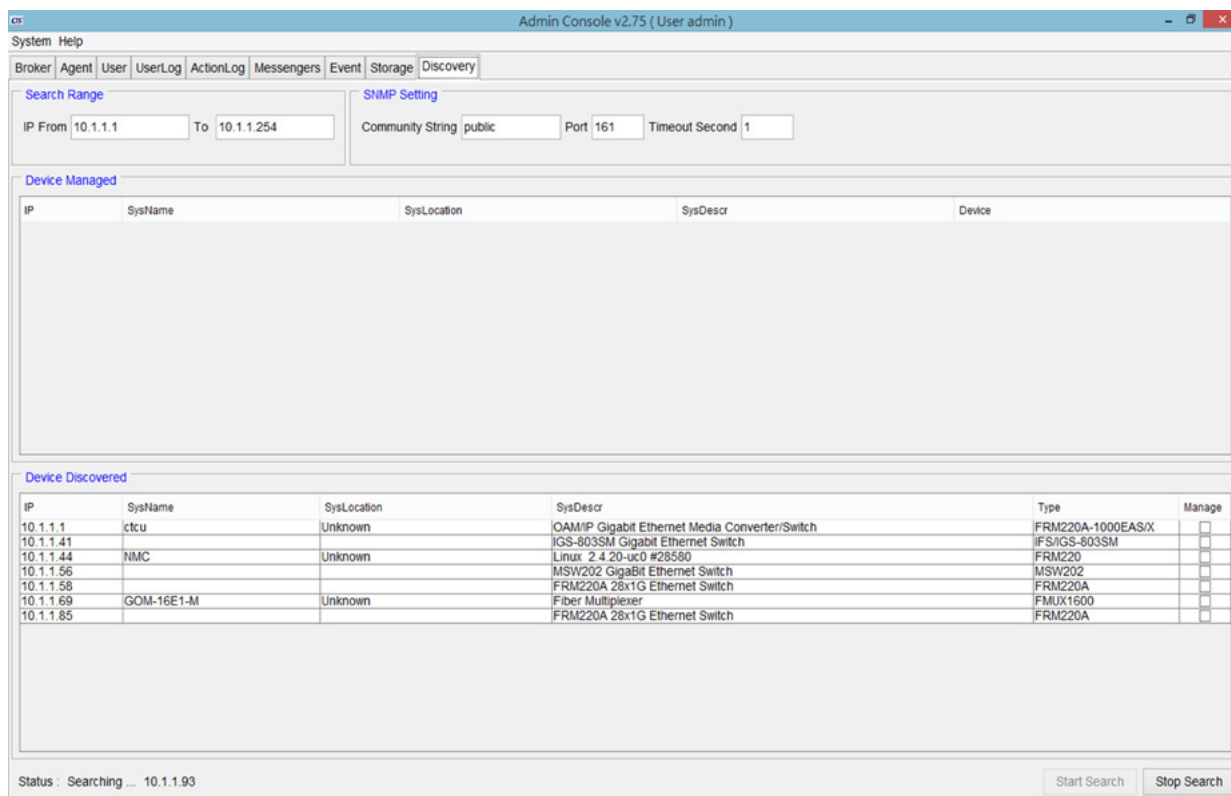

Network Element Discovery

- Accounting Management

The accounting management supports reading a factory programmed serial number specific for each line card. The location, status and serial numbers of all assets can be managed and exported.

Element Management Console v2.57 (User admin)

System Tool Help

Network Alarm Trap Performance PMGraph Inventory

Type: Inventory Time: [] Device: All Status: All Serial Number: [] Identity: []
 Summary To: [] Location: All Racks All Slots All Sites Type: [] Alias: [] Remark: [] Clear

Inventory

Page : 1 / 2 [First] [Previous] [Next] [Last] [Refresh]

No.	Device	Address	Location	Type	HW Version	FW Version	Serial Number	Alias	Status	Date
1	FRM220-44	10.1.1.44	Rack:1 Slot:10 Local	Protection	1.100	1.050	098765432101234567890		On Line	2013-10-31
2	FRM220-44	10.1.1.44	Rack:1 Slot:19 Local	1002ES	1.100	1.000	888888888888888888888888		On Line	2013-10-31
3	FRM220-44	10.1.1.44	Rack:1 Slot:1 Local	NMC	1.01	3.54	F1234V012901313A00001		On Line	2013-10-31
4	FRM220-44	10.1.1.44	Rack:1 Slot:7 Local	8E1ET100S	1.300	1.226	10124A3680000003861		On Line	2013-10-31
5	FRM220-44	10.1.1.44	Rack:1 Slot:8 Local	100IS_2	1.100	2.000	F887B358D9198696ZNB0		On Line	2013-10-31
6	FRM220-44	10.1.1.44	Rack:1 Slot:9 Local	100IS	1.100	2.000	07203D1271246E6B2WS		On Line	2013-10-31
7	FRM220-44	10.1.1.44	Rack:1 Slot:12 Local	10GE_TS	1.100	1.001	W6000357937260927635		On Line	2013-10-31
8	FRM220-44	10.1.1.44	Rack:1 Slot:13 Local	10G_SXX	1.100	2.00B	None		On Line	2013-10-31
9	FRM220-44	10.1.1.44	Rack:1 Slot:14 Local	3R10G_SS	1.100	2.008	8885AC34D90429A0DDA		On Line	2013-10-31
10	FRM220-44	10.1.1.44	Rack:1 Slot:15 Local	EOE1G	1.100	1.023	None		On Line	2013-10-31
11	FRM220-44	10.1.1.44	Rack:1 Slot:16 Local	EOE1G	1.100	1.023	BE37559BB78FBE82FD0		On Line	2013-10-31
12	FRM220-44	10.1.1.44	Rack:1 Slot:17 Local	100M	1.000	1.050	0AD7BEB10B6BYC6T7C3		On Line	2013-10-31
13	FRM220-44	10.1.1.44	Rack:1 Slot:18 Local	100M	1.100	1.050	4PXRW2XKWBGYV33FB7		On Line	2013-10-31
14	FRM220-44	10.1.1.44	Rack:1 Slot:20 Local	1000M	1.100	1.070	A2C46823E6E44AWSW6		On Line	2013-10-31
15	FRM220A-46	10.1.1.46	Rack:0 Slot:1 Local	1000EASX	1.200	1.026	0003579372609276304CA		Off Line	2013-10-31
16	FRM220A-46	10.1.1.46	Rack:0 Slot:2 Local	1000EASX	1.300	1.029	None		Off Line	2013-10-31
17	FRM220A-46	10.1.1.46	Rack:0 Slot:3 Local	1000EASX	1.200	1.026	5F4B31307FB6BYC6T124		Off Line	2013-10-31
18	FRM220A-46	10.1.1.46	Rack:0 Slot:4 Local	1000EASX	1.200	1.026	A36800000038617C34PX		Off Line	2013-10-31
19	FRM220A-46	10.1.1.46	Rack:0 Slot:5 Local	1000EASX	1.300	1.026	RW2XKWBGYV33099E07		Off Line	2013-10-31
20	FRM220A-46	10.1.1.46	Rack:0 Slot:10 Local	5E1ET100S	1.300	1.226	437FB4C0EC93755FD100		Off Line	2013-10-31
21	FRM220A-46	10.1.1.46	Rack:0 Slot:11 Local	5E1ET100T	1.200	1.061	None		Off Line	2013-10-31
22	FRM220A-46	10.1.1.46	Rack:0 Slot:12 Local	5E1ET100T	1.200	1.061	None		Off Line	2013-10-31
23	FRM220A-46	10.1.1.46	Rack:0 Slot:13 Local	5E1ET100T	1.200	1.061	AL3T8C3QRBRK234CD		Off Line	2013-10-31
24	FRM220A-46	10.1.1.46	Rack:0 Slot:14 Local	5E1ET100S	1.300	1.226	7MG7D43TC3M392BWSW		Off Line	2013-10-31
25	FRM220A-46	10.1.1.46	Rack:0 Slot:15 Local	8E1ET100T	1.200	1.061	None		Off Line	2013-10-31
26	FRM220A-46	10.1.1.46	Rack:0 Slot:16 Local	8E1ET100S	1.200	1.061	6000357937260927632BC		Off Line	2013-10-31

[Export] [Edit] [Delete]

Inventory List

Element Management Console v2.57 (User admin)

System Tool Help

Network Alarm Trap Inventory

Type: Inventory Time: [] Device: All Status: All Serial Number: [] Identity: []
 Summary To: [] Location: All Racks All Slots All Sites Type: [] Alias: [] Remark: [] Clear

Summary [Refresh]

No.	Device	Type	On Line	Off Line	Total
1	FRM220				
2		NMC	1	0	1
3		1000M	1	0	1
4		1002ES	1	0	1
5		100IS_2	2	0	2
6		100M	2	0	2
7		10GE_TS	1	0	1
8		10G_SXX	1	0	1
9		3R10G_SS	1	0	1
10		8E1ET100S	2	0	2
11		EOE1G	2	0	2
12		Protection	1	0	1
13					
14	FRM220A				
15		1000EASX	0	4	4
16		1002ES	0	2	2
17		16E1ET100T	0	1	1
18		5E1ET100S	0	2	2
19		5E1ET100T	0	3	3
20		8E1ET100S	0	1	1
21		8E1ET100T	0	1	1
22		FSW103	0	1	1
23					

[Export]

Inventory Summary

- Performance Management

SmartView™ is able to monitor device performance parameters through polling of specific OIDs. Graphs of performance information (for example PDH PM data such as ES, UAS, etc. as well as hardware parameters such as fan speed, temperature, optical Tx/Rx power or RMON counters) can be generated on an XY axis showing different trend data.

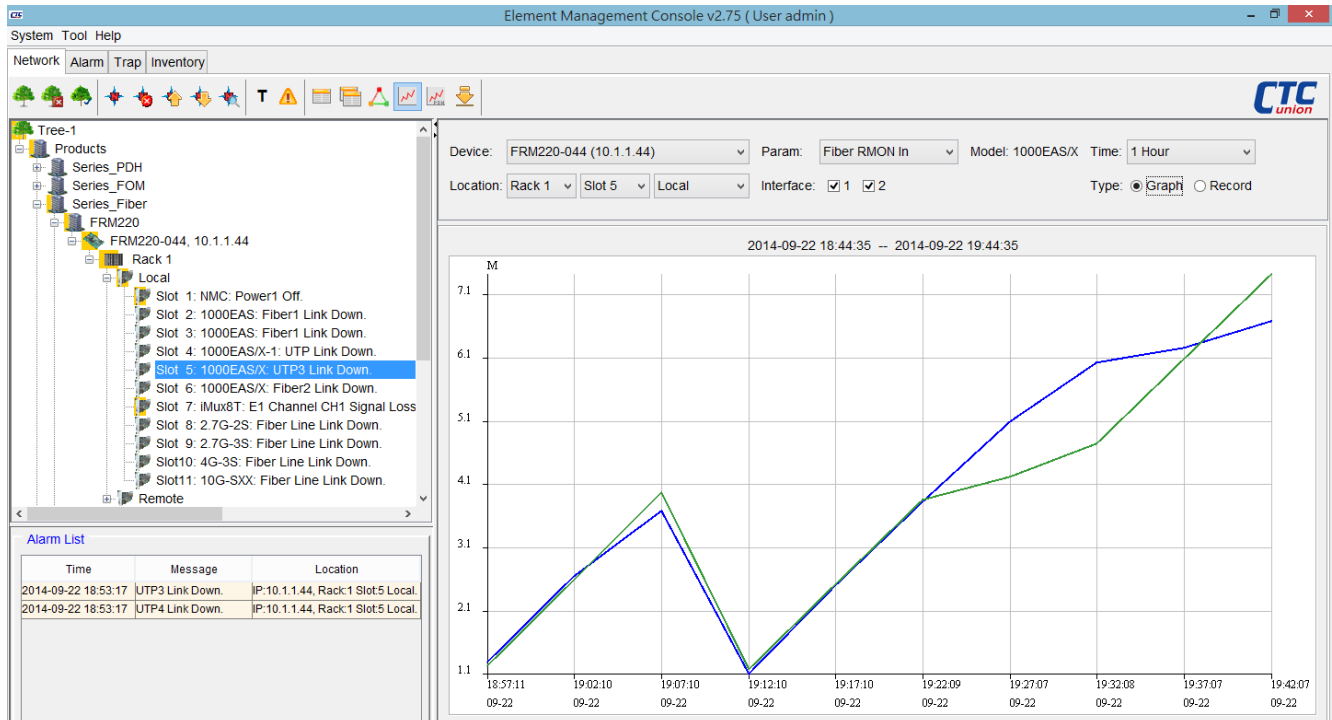

Performance Graphics

No.	Device	Address	Type	Location	Time	Param	Interface	Value
1	FRM220-044	10.1.1.44	FRM220	Rack:01 Slot:05 Local	2014-09-22 18:57:11	Fiber RMON In	1	1331040
2	FRM220-044	10.1.1.44	FRM220	Rack:01 Slot:05 Local	2014-09-22 18:57:11	Fiber RMON In	2	1270944
3	FRM220-044	10.1.1.44	FRM220	Rack:01 Slot:05 Local	2014-09-22 19:02:10	Fiber RMON In	1	2677120
4	FRM220-044	10.1.1.44	FRM220	Rack:01 Slot:05 Local	2014-09-22 19:02:10	Fiber RMON In	2	2621536
5	FRM220-044	10.1.1.44	FRM220	Rack:01 Slot:05 Local	2014-09-22 19:07:10	Fiber RMON In	1	3711872
6	FRM220-044	10.1.1.44	FRM220	Rack:01 Slot:05 Local	2014-09-22 19:07:10	Fiber RMON In	2	4005216
7	FRM220-044	10.1.1.44	FRM220	Rack:01 Slot:05 Local	2014-09-22 19:12:10	Fiber RMON In	1	1132512
8	FRM220-044	10.1.1.44	FRM220	Rack:01 Slot:05 Local	2014-09-22 19:12:10	Fiber RMON In	2	1210720
9	FRM220-044	10.1.1.44	FRM220	Rack:01 Slot:05 Local	2014-09-22 19:17:10	Fiber RMON In	1	2538752
10	FRM220-044	10.1.1.44	FRM220	Rack:01 Slot:05 Local	2014-09-22 19:17:10	Fiber RMON In	2	2547776
11	FRM220-044	10.1.1.44	FRM220	Rack:01 Slot:05 Local	2014-09-22 19:22:09	Fiber RMON In	1	3869792
12	FRM220-044	10.1.1.44	FRM220	Rack:01 Slot:05 Local	2014-09-22 19:22:09	Fiber RMON In	2	3887840
13	FRM220-044	10.1.1.44	FRM220	Rack:01 Slot:05 Local	2014-09-22 19:27:07	Fiber RMON In	1	5125632
14	FRM220-044	10.1.1.44	FRM220	Rack:01 Slot:05 Local	2014-09-22 19:27:07	Fiber RMON In	2	4259328
15	FRM220-044	10.1.1.44	FRM220	Rack:01 Slot:05 Local	2014-09-22 19:32:08	Fiber RMON In	1	6058112
16	FRM220-044	10.1.1.44	FRM220	Rack:01 Slot:05 Local	2014-09-22 19:32:08	Fiber RMON In	2	4776704
17	FRM220-044	10.1.1.44	FRM220	Rack:01 Slot:05 Local	2014-09-22 19:37:07	Fiber RMON In	1	6298752
18	FRM220-044	10.1.1.44	FRM220	Rack:01 Slot:05 Local	2014-09-22 19:37:07	Fiber RMON In	2	6116768
19	FRM220-044	10.1.1.44	FRM220	Rack:01 Slot:05 Local	2014-09-22 19:42:07	Fiber RMON In	1	6715360
20	FRM220-044	10.1.1.44	FRM220	Rack:01 Slot:05 Local	2014-09-22 19:42:07	Fiber RMON In	2	7452320

Performance Records

• Security Management

User Privilege

- The administrator can add necessary user logins with specific privileges, from Administrator to Operator and lastly to normal user.
- Radius Authentication. Supports authentication login provided by credentials stored on RADIUS server.

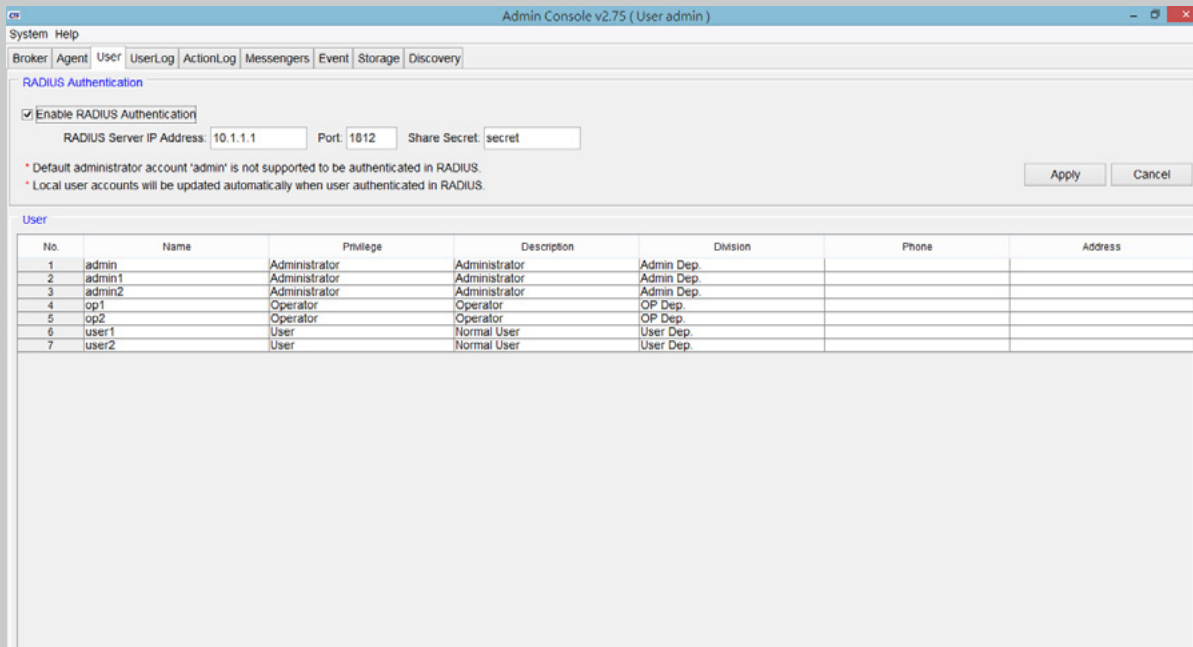

User Privilege

User Activity

Provides viewing and clearing of the user login and configuration action logs.

User client login & logouts are recorded, including the client's source IP address. All activities performed on any Network Element are logged with time-stamping, the user making changes and the changes made.

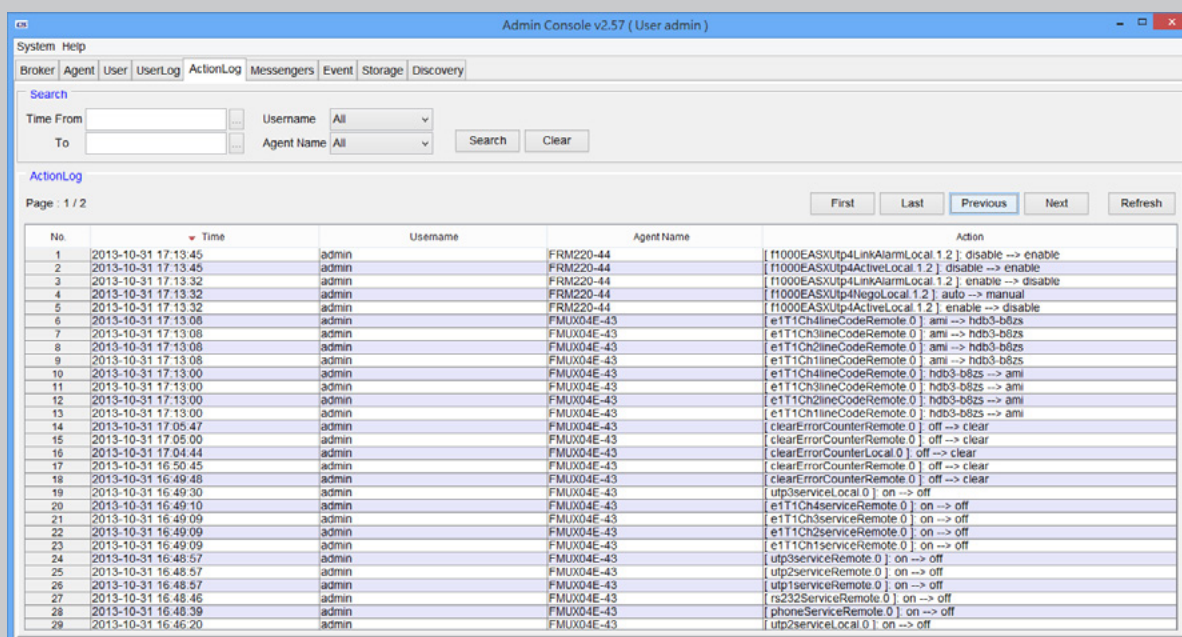

User Activity

Requirements

SmartView™	Hardware (minimum)	Software	Operating System
SmartView™ Server	Intel Core2 or higher processor, 2GB RAM, 40GB HD	JAVA JRE, SmartView™ Kit, MS-SQL Server	Windows 2008/2012 Server, Windows Vista, Win 7/8
SmartView™ Clients	Intel Core2 or higher processor, 2GB RAM, 20GB HD	JAVA JRE, SmartView™ Kit.	Windows Vista, Win 7/8
All-In-One	Intel Core2 or higher processor, 4GB RAM, 80GB HD	JAVA JRE, MS-SQL Server, SmartView™ Kit, SmartView™ Server/Client	Windows 2008/2012 Server, Windows Vista, Win 7/8

Ordering Information

SmartView™ Platform Server with Device Agents

Model Name	Description
SV1-AGT-50	SmartView™ Platform with 50 device agents
SV1-AGT-100	SmartView™ Platform with 100 device agents
SV1-AGT-200	SmartView™ Platform with 200 device agents
SV1-AGT-500	SmartView™ Platform with 500 device agents



Central EMS

Element Management System

- Allow central management of up to 50 SmartView™ servers
- Allow up to 25,000 devices management
- Long term historical query (up to 1 year)
- Easy and User-Friendly Operation Interface

Main Function

Centralized and Large Scale Network Management Platform

Central EMS provides centralized device management for large scale networks by supporting up to 50 SmartView EMS Servers and tens of thousands of network devices.

Hierarchical Network Management Architecture

Each area can deploy a proprietary SmartView EMS Server, responsible for collecting local information for up to 500 network devices, and relay to Central EMS management platform. Central EMS management platform can aggregate and manage SmartView EMS Server SNMP trap information for all regions and provide real time information and status of local and remote network devices.

Easy and rapid expansion of network management scale.

When the number of device elements is continuously expanding, operators can deploy one or more SmartView EMS Servers to cover new areas. Using Central EMS device management platform, new SmartView servers can be quickly and easily added to the expanding network.

Provides OSS (Operations Support System) Level Management Function.

Central EMS Management Platform provides Fault management, Configuration management, Accounting management, Performance management and Security management (FCAPS).

Server/Client Remote management architecture

Central EMS management platform can support 25 connections for remote operations managers at the same time.

Simple and convenient user interface

Using a user friendly GUI (Graphical User Interface), Central EMS provides a familiar point and click interface.

Architecture

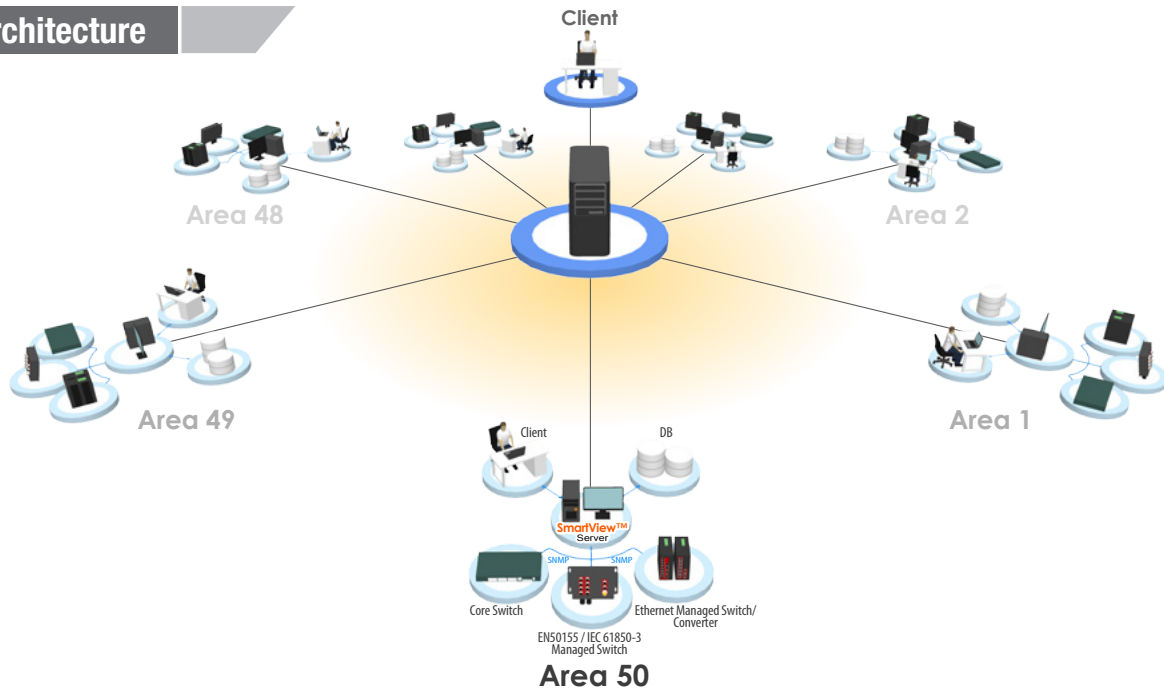

Central EMS

Supports 50 SmartView™ EMS (Max.)

Requirements

Central EMS	Hardware (minimum)	Operating System
Central EMS Server	Intel Core2 or higher processor, 4GB RAM, HD >2GB (free).	Windows 2008/2012 Server, Windows 7/8
Workstation-Clients	Intel Core2 or higher processor, 4GB RAM, HD >2GB (free).	Windows 7/8
All-In-One	Intel Core2 or higher processor, 8GB RAM, HD >20GB (free).	Windows 2008/2012 Server, Windows 7/8

Ordering Information

Model Name	Description
Central EMS-01	Central Element Management System

Access Transmission Solution

Mobile Backhaul



Cloud Services



Triple Play Services



Industry



Technology Park



Government



Data Center



Bank



Campus

iAccess™ Multi-Service Platform

- Mobile Fronthaul & Backhaul for 4G LTE
- 40G/10G Ethernet for Data Center Solution
 - Carrier Ethernet (NID & EDD)
 - CWDM & DWDM



iAccess™ Multi-Service Platform - FRM220 Series

In-Band Managed Multi-Service Platform-FRM220-CH20/08/04A



The FRM220 series is a multi-service chassis platform, which provides a reliable solution of high density media converter modules for applications such as telecom operator, enterprise, long haul transmission and factory automation. All of critical components of FRM220-CH20 and FRM220-CH08 chassis such as power modules, fans, management module and interface cards are hot swappable, allowing online field replacement. FRM220-CH04A is a fixed type AC, DC power built-in chassis. The available power options are built-in AC, DC power or built-in AC+DC, AC+AC, DC+DC redundant power.

FRM220 series is offered in three chassis densities, a 2U 20-slot (FRM220-CH20), a 1U 8-slot (FRM220-CH08), and a 1U 4-slot (FRM220-CH04A)

Feature

- Supports AC/DC power module hot swappable and power redundancy (CH20 & CH08)
- Supports fixed type AC/DC power built-in and power redundancy (CH04A)
- Two alarm relays contact for critical events warning
- Interface cards are hot swappable
- Chassis backplane consists of passive components

Specifications

Connectors	Console: RS232 (DB9), LAN 10/100Base-TX RJ45		Power	DC24	18~36VDC (CH20/CH08)
Physical Specifications	Dimensions (D x W x H)	303 x 438 x 88 mm (CH20)	DC48	36~75VDC (CH20/CH08)	
		310 x 440 x 44 mm (CH08)	AC	100~240V (CH04A)	
		170 x 310 x 44.7 mm (CH04A)	DC	18~75VDC (CH04A)	
Temperatures	Operating 0~60°C, Storage -10~70°C	Weight	Humidity	5%~90% non-condensing	
		5.2kg (CH20), 3.5kg (CH08) (w/o Power) 1.9kg (CH04AD), 1.5kg (CH04AC/DC)	MTBF	65,000 hrs	
Power	AC	100~240VAC (CH20/CH08)	Certification	FCC Class A, VCCI Class A, CE	
			Safety	UL 60950-1 (FRM220-CH20)	

iAccess Platform Solutions

iAccess™ Multi-Service Platform solutions offer a full range of solutions for service provider and enterprise, including high density 40G/16G connectivity, DWDM, CWDM, distance extension, Ethernet Switch/NID, Fiber Modem, Fiber Multiplexer and Media Converter. It is a fully modular product series that integrates a wide range of optical transport modules for any interface or protocol hosted in selection of Chassis size for simple and flexible operations.

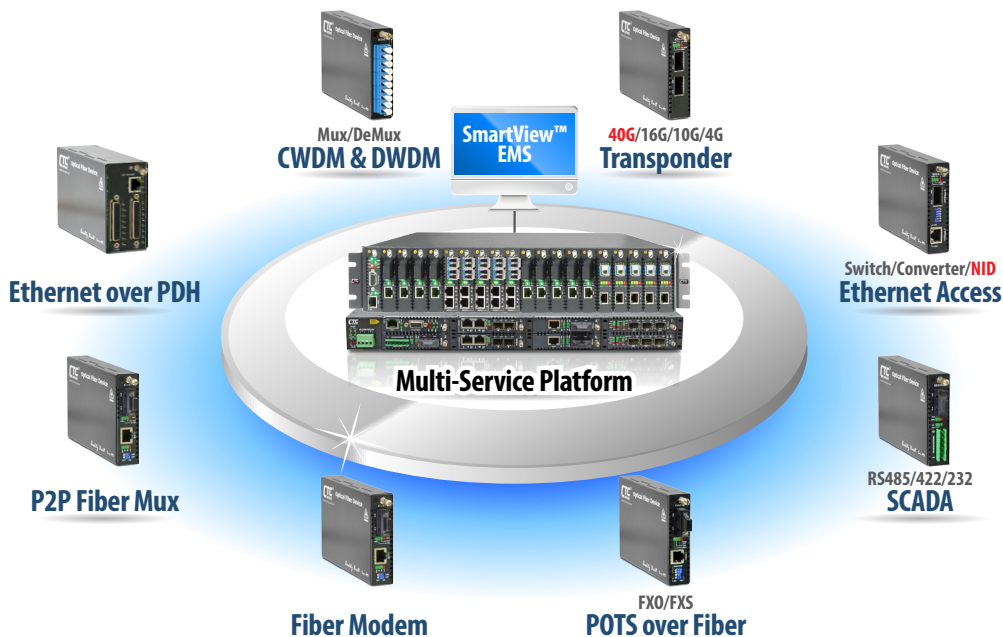

Main Features

• Module Cards for Deployment Scenarios

The FRM220-CH20, FRM220-CH08 and FRM220-CH04A have been designed as a Multi-service platform. This allows network administrators to deploy the chassis in a wide range of networks.

Technologies supported by the chassis include Fast/Gigabit Ethernet, E1/T1, V35/X21/RS-530, Serial RS-485/RS-422, Voice FXO/FXS, Repeater, Fiber Multiplexer, E1 Inverse Multiplexer, CWDM Mux/DeMUX and 10G/16G 3R Transponder

• Network Management

The FRM220-CH20, FRM220-CH08 and FRM220-CH04A require a NMC (Network Management Controller FRM220-NMC page: 2-3) card which must be installed into the first slot of chassis. The NMC card allows a network administrator the ability to configure and monitor the status of the blades. Management can be achieved locally over RS232, or over the network by Telnet, Web or SNMP. If the blades support Ethernet in the First Mile (IEEE 802.3ah), then the management module can also be monitored the status of a remote CPE.

Access Transmission Application

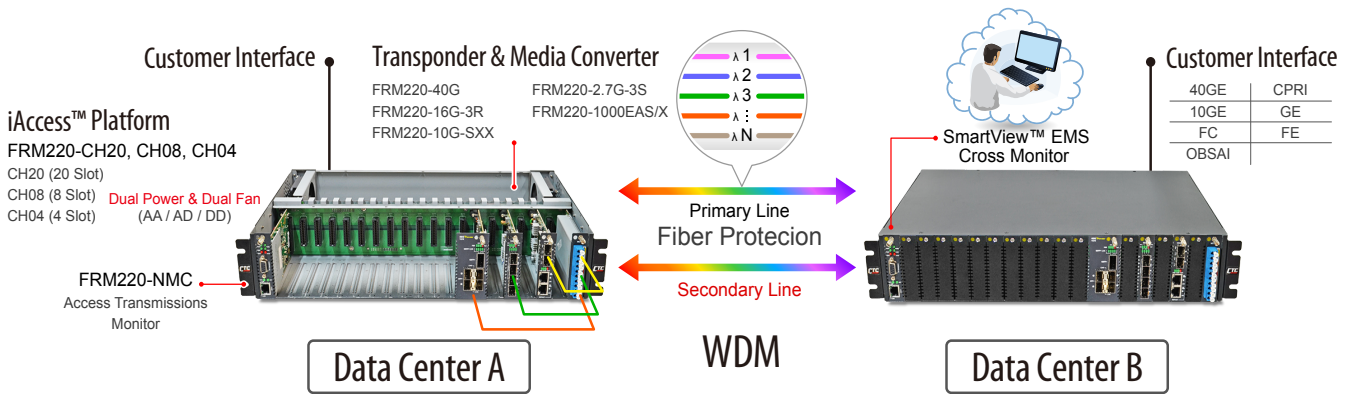

Chassis Overview

• FRM220-CH20 (2U 19" 20 Slots)

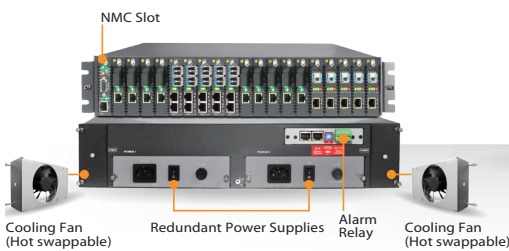

• FRM220-CH08 (1U 19" 8 Slots)

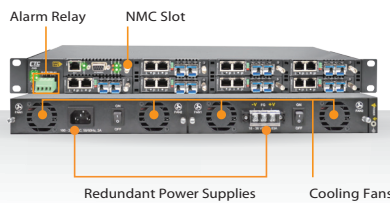

• FRM220-CH04A (1U 4 Slots)



Ordering Information

Model Name	Type	Description
FRM220-CH20	Chassis	2U 20-Slot rack mount chassis with 20 line card blank plate
CH20-AC	Power	Chassis power module 100 ~ 240 VAC, IEC connector
CH20-DC24	Power	Chassis power module 18 ~ 36 VDC, 3 pin terminal block, 200W
CH20-DC48	Power	Chassis power module 36 ~ 72 VDC, 3 pin terminal block, 200W
FRM220-CH08	Chassis	1U 8 slots rack mount chassis with 8 line card blank plate, 200W
CH08-AC	Power	Chassis power module 100 ~ 240 VAC, IEC connector, 120W
CH08-DC24	Power	Chassis power module 18 ~ 36 VDC, 3 pin terminal block, 200W
CH08-DC48	Power	Chassis power module 36 ~ 72 VDC, 3 pin terminal block, 200W
CH04A-AC	Power	Four slot chassis with built-in AC power, 65W
CH04A-DC	Power	Four slot chassis with built-in DC power, 50W
CH04A-AD	Power	Four slot chassis with built-in AC+DC power (65W/50W)



FRM220-NMC Network Management Controller

The FRM220-NMC is a Network Management Controller card that can be placed in a compatible FRM220 series chassis to provide device management functions. The management interface supports a local RS-232 serial console or remote TCP/IP management by Telnet, HTTP and SNMP protocols. The card is designed to be hot swapped so that it may be field replaced without affecting any online service of any other rack cards. The card also supports online firmware upgrade from TFTP server, using any user interface, without affecting any other inserted line card's transmissions. Support for any standard NMS is provided by the included enterprise MIB file. CTC Union also provides and maintains our own EMS (Element Management System) which is a Java based client/server manager for monitoring and maintaining a large number of network elements over a long period of time.

Feature

NMC provides central management for FRM220-CH20, FRM220-CH08, FRM220-CH04A and CH02-NMC

- User interfaces for serial console, Telnet & Web
- Configure, monitor and provide fault management for all installed line cards
- Monitor power and fan status in chassis
- Provides upgrade feature for most line card types
- SNMP agent for complete management by enterprise software
- Running System log with time stamping for SNTP (time server)
- Parameter management for quick configuration, configuration copy/backup/restore
- Card alias and inventory by type and serial number
- Linux Kernel based for high stability and reliability



◀ FRM220-NMC



(2U/19" rack mountable, 20 slots)

▪ FRM220-NMC must be installed in to the first slot of chassis.



◀ FRM220-NMC



(1U/19" rack mountable, 8 slots)



◀ FRM220-NMC



(1U, rack mountable, 4 slots)

The local area screen (Figure 1) is also the home page for the Web management of the NMC. An overview of all installed network interface cards (NIC) is shown with real-time status of LEDs. To enter the configuration screen for a NIC, simply click on the card.

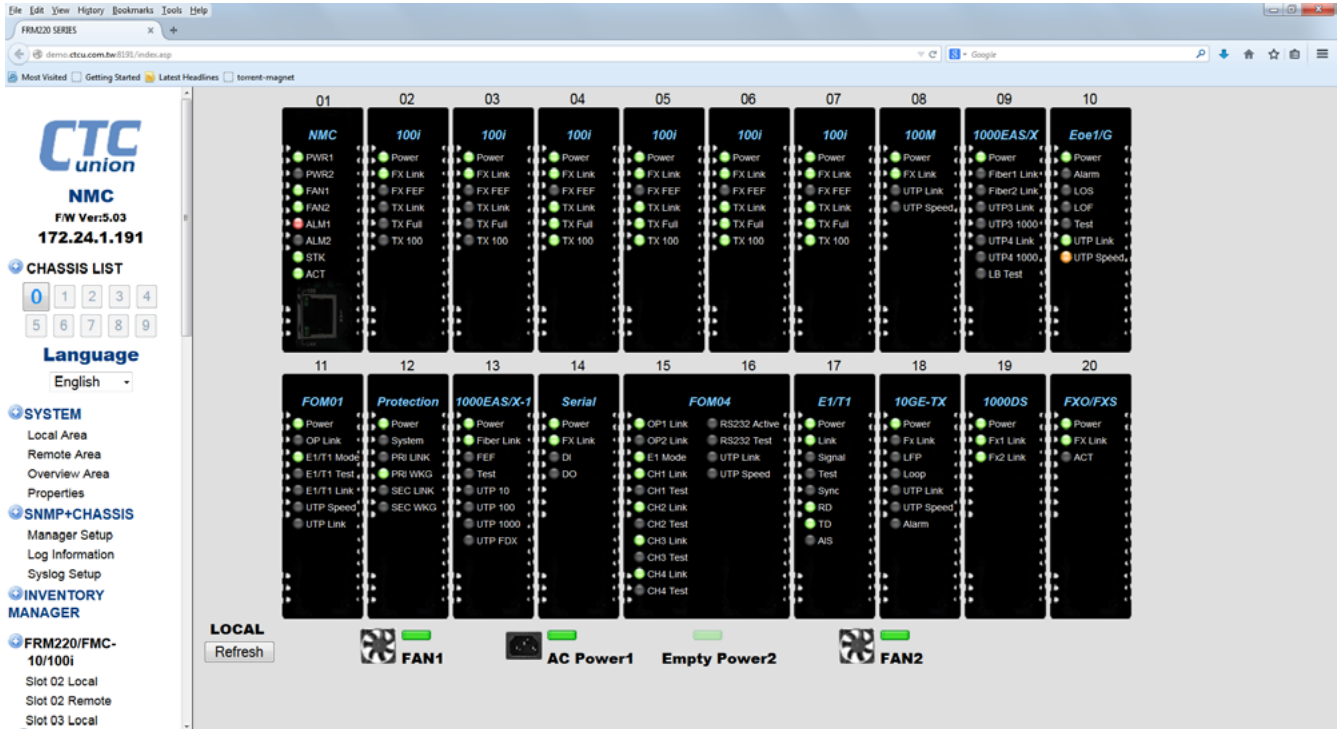

Figure 1

The SNMP+CHASSIS screen (Figure 2) gives a quick overview of the power and fan status in the chassis. This page is also used to assign the alarm conditions for the two programmable alarms. These alarms activate the electrical relays, display messages in the system log and can generate SNMP traps when a trap receiver is configured.

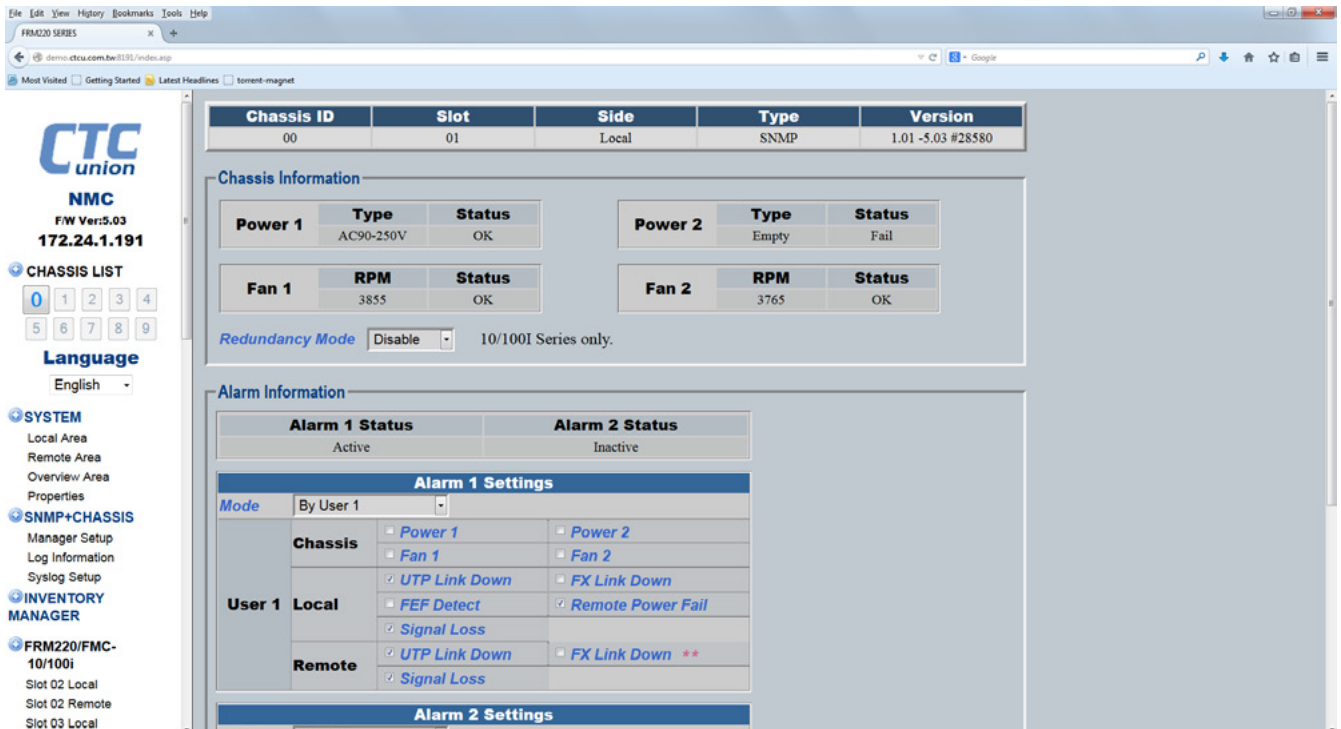

Figure 2

Network Management Controller

The system setting screen (Figure 3) has the functions for NMC upgrade, line card upgrade, system time and card parameter management.

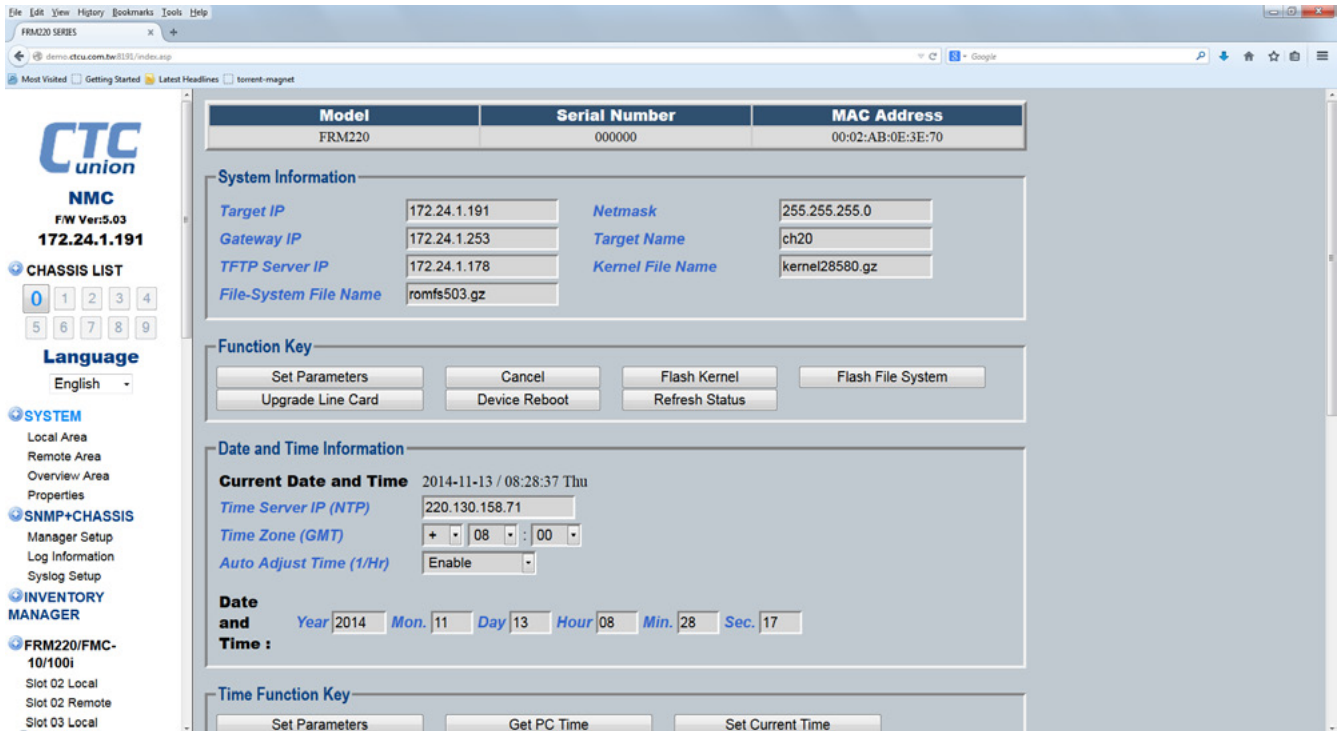

Figure 3

The management (Figure 4) can call up each line card to view detailed status and to make configuration changes to the card. By using a Web GUI, the settings can be made with simple mouse point and click actions.

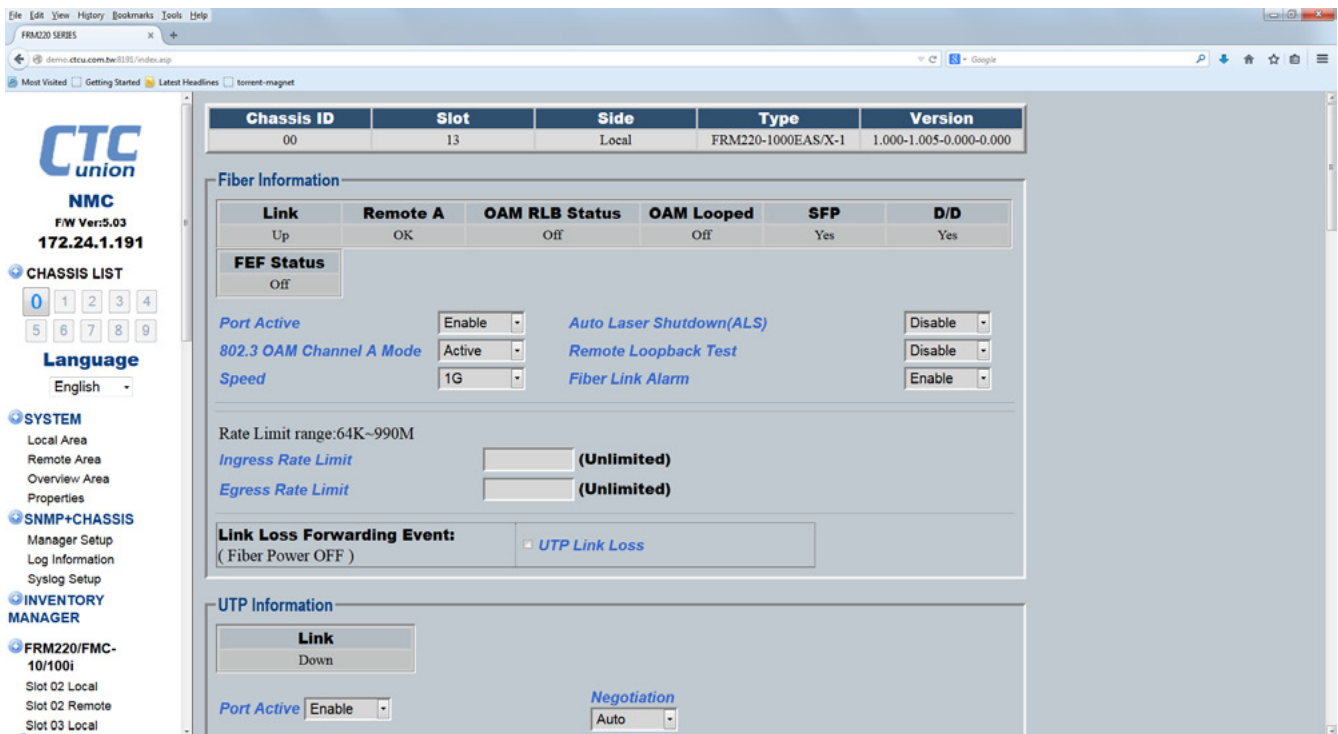

Figure 4

Ordering Information

Model Name	Type	Description
FRM220-NMC	Card	Network Management Controller card, support web, telnet, console, SNMP functions

Standalone Chassis for FRM220 Series

All of FRM220 series rack mount cards are hot-swappable and can be installed in a 20 slots (2U), or 8 slots (1U) rack-mountable chassis with any combination of redundant hot swappable AC, 24VDC or 48VDC power supplies, providing a scalable solution that is space-efficient and cost-effective. The rack mount cards can also be mounted in 4 slots, 2 slots, or 1 slot standalone housing with fixed AC/DC powered chassis.

The rack mount cards of FRM220 series provide telecommunication solutions for most applications. CTC union offers a universal and cost-efficient transmission series for a variety of fiber optic technologies (Multimode, Single mode, WDM, CWDM) starting from converters and switches, to modems and extending to intelligent voice/data multiplexer systems. The products are designed as rack mount cards in combination with various chassis types. The concept is to ensure an extremely variable mixture of products at low storage costs for spares.

Power Build-in Type

Power Build-in Type

FRM220-CH01



FRM220-CH01M



FRM220-CH02M & CH02M-2

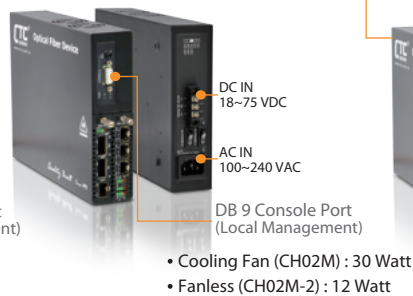

FRM220-CH02/NMC

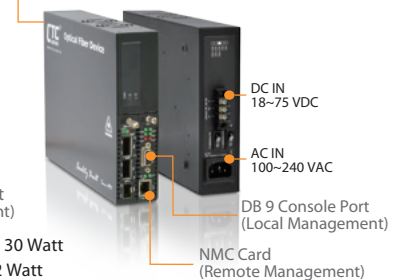

Adapter Type

FRM220-CH01



FRM220-CH02



Feature

- Fanless (CH01, CH01M, CH02, CH02M-2)
- Cooling Fan (CH02M, CH02/NMC)
- Supports DB9 console port for local management (CH01M, CH02M, CH02M-2)
- Telnet, Web, Console, SNMP management via NMC Card (CH02/NMC)

Power Type:

- External Power: DC12
- Internal Power: AC, DC, AD, AA or DD redundant power (option)

Standalone Chassis

Specifications

Power Input (Option)	External Adapter	Input Voltage 100~240VAC 50/60Hz
		Output Voltage 120VDC 1A
	Internal Power	AC: 100~240VAC
		DC: 18~75VDC
Weight	0.5~0.8kg (CH01) , 0.9kg (CH01M)	
	0.8kg (CH02), 1.3kg (CH02M), 1.2kg (CH02M-2), 1kg (CH02/NMC)	

Dimensions (D x W x H)	External Adapter	139x 23.2x 88mm (CH01)
		139x 44.5x 88mm (CH02)
	Internal Power	180x 30x 135mm (CH01)
		185x 30x 135mm (CH01M)
		222.7x 45.5x 167.4mm (CH02M, CH02M-2, CH02/NMC)

FRM220 Slide-In Card Chassis Order Information

Model Name	Description
CH01	1 Slot Chassis with 100 ~240VAC to 12VDC Adapter, Fanless
CH01-AC,DC,AD	1 Slot Chassis with AC: 100 ~240VAC DC: 18 ~72VDC or Dual Power (AC+DC), Fanless
CH01M-AC,DC,AD	1 Slot Chassis with Console port and AC: 100 ~240VAC, DC: 18 ~72VDC or Dual Power (AC+DC), Fanless
CH02	2 Slots Chassis with 100 ~240VAC to 12VDC Adapter, Fanless
CH02M-AC,DC,AD	2 Slots Chassis with Console port and AC: 30W 100 ~240VAC, DC:30W 18 ~72VDC or Dual Power (AC+DC), with Cooling Fan
CH02M-2-AC,DC,AD	2 Slots Chassis with Console port and AC:12W 100 ~240VAC, DC:12W 18 ~72VDC or Dual Power (AC+DC), Fanless
CH02/NMC (S)-AC,DC,AD	2 Slots Chassis with NMC card and AC:100 ~240VAC, DC:18 ~72VDC or Dual Power (AC+DC), with Cooling Fan

FRM220 – □□□□ – □□

Example: FRM220 – CH01 – AD

NEW



FRM220-40G-1Q4S

40G QSFP to 4x 10G SFP+ Transponder

2

40G Transponder

The FRM220-40G-1Q4S is a 40G QSFP to 4x 10G SFP+ transponder that provides media conversion and distance extension for 40G over 10G links. The FRM220-40G-1Q4S meets the growing need for more bandwidth for data centers and enterprises. The emergence of high-end servers and Ethernet switches with 40G Ethernet interfaces increases the need for media conversion (multi-mode to single-mode) and link range extension. The FRM220-40G-1Q4S is hot-swappable with one QSFP slot for QSFP 40G transceiver and four SFP+ slots for SFP+ 10G transceiver. The installation and setup is simple plug and play. The FRM220-40G-1Q4S can be inserted into any powered FRM220-CH20 chassis with QSFP and SFP+ transceivers required for the application.

Feature

- Network Management via FRM220 Chassis
- Multiple functions in one module: 40G converter/repeater and Quad 10G optical multiplexer
- 40G link interface --Ethernet/IEEE: 802.3ba 40GE-LR4
- 40G multi-link (fiber) interfaces --Ethernet/IEEE: 802.3ba XLAUI and OIF: CEI-11G
- Aggregate Data Rate: 10G x 4
- Data Rate per Lane: 8 ~ 14.2G
- QSFP ports for flexibility and scalability
- Hot-swap support (module and interfaces)
- Supports 1x 40G Mode and 4x 10G Modes
- Supports DMI function for QSFP fiber module
- Supports Loopback test function
- 3R function.

Specifications

Equipment function	3R Transponder, Regenerator, Reshaper, Retimer	Protocol	Ethernet 10G
Protocol	Multiple functions in one module: 40G converter/repeater—Quad 10G optical multiplexer 40G link interface	Interface Type	40Gbps : QSFP (1 port), 10Gbps : SFP+ (4 ports)
Aggregate Data Rate	32 - 56.8 Gbps	Transmission Distance	Up to QSFP module
Data Rate per Lane	8 - 14.2 Gbps	Power requirement	Power input 12VDC Power consumption: ≤12W
Ethernet/IEEE CPRI	802.3ba 40GBASE-LR4/SR4 x16	Work Environment	Operating Temperature 0 ~ 50°C Storage Temperature -10 ~ 70°C Humidity 10 ~ 90% (non-condensing)
STM	64	Dimension	Card: 155 x 23 x 88mm (D x W x H)
OC	192		
FC	8G, 10G, 16G		

Application

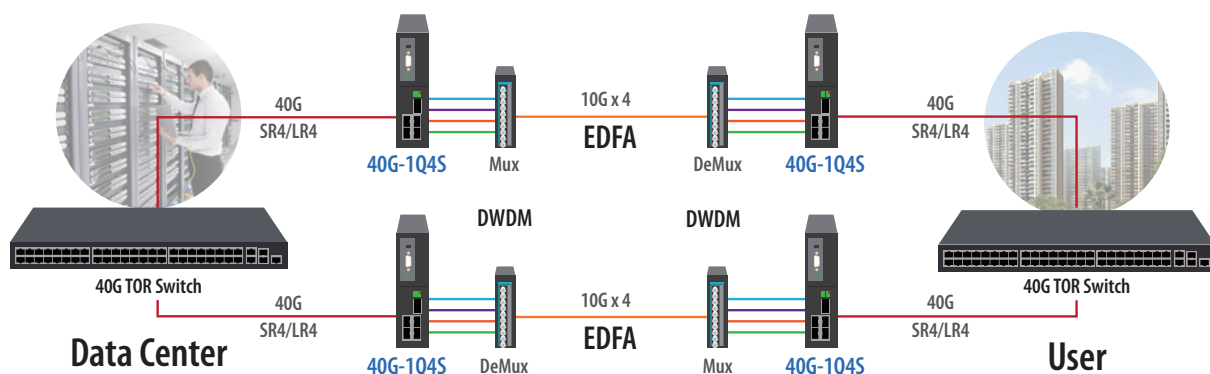

Ordering Information

Model Name	Description
FRM220-40G-1Q4S	40G converter/repeater, Quad 10G Optical Multiplexer module with QSFP Interfaces

Accessories

10G SFP+ Transceiver Module

SFM-1000-SR85	10G SFP+ SR/SW MMF 300m, 850nm VCSEL, 10G Ethernet/FC/SDH/SONET
SFS-1010-LR31	10G SFP+ LR/LW SMF 10km, 1310nm DFB DML, 10G Ethernet/FC/SDH/SONET
SFS-1040-ER55	10G SFP+ ER/EW SMF 40km, 1550nm DFB EML, 10G Ethernet/FC/SDH/SONET
SFS-1080-ZR55	10G SFP+ ZR/EW SMF 80km, 1550nm DFB EML, 10G Ethernet/FC/SDH/SONET



FRM220-16G-3R

16G 3R Multi-rate Transponder

The FRM220-16G-3R has 4 SFP+ slots that can be configured as a dual channel 16G 3R multi-rate transponder or in a 1-to-2 port protection mode. The device provides a flexible transmission of various protocols, such as 1G/10G Ethernet, SDH STM16/STM64, OTU1/OTU1e/OTU2/OTU2e, Fiber Channel 1/2/4/8/10/16, ODU, OBSAI, CPRI, etc. Using SFP+ ports with dedicated CWDM or DWDM wavelengths, the 16G transponder supports multi-rate functionality with optical data rates from 1Gbps up to 14Gbps. With its functionality the FRM220-16G-3R transponder is also suitable as a repeater for transmission over extended distances. In addition, the use of state of the art components greatly reduces the power requirements and heat dissipation factors over our previous transponders.

Feature

- Multi-rate supports 1Gbps ~ 14Gbps
- Protocol Transparent 3R fiber Media Transponder / Repeater
- Supports 1+1 Optical Line Protection
- Supports 2 channels with different bit rate.
- Supports Loopback Test.
- SFP DDM Information
- Firmware Upgrade
- Setting from DIP Switch, Console, NMC
- Supports FRM220 -CH01M, CH02M, CH04A, CH08, CH20
- FRM220-CH20, Full Load (19 Slots)

Specifications

Optical Interface	Connector	LC (SFP+, SFP)
	Wavelength	CWDM 1271 ~ 1611nm DWDM 1529.5~1565.50nm
Operation mode	Dual channel mode : Ch 1 SFP1 line / SFP2 client. Ch2 SFP3 line/ SFP4 client. Protection mode : SFP1 line / SFP2, SFP3 client	
Protocol	SONET	OC-24, OC-48, OC-192
	SDH	STM-16, STM-64
	Ethernet	1G, 2.5G, 10G
	OTU	OTU1, OTU1e, OTU2, OTU2e
	ODU	ODU1, ODU1e, ODU2, ODU2e
	OBSAI	OBSAI x1, x2, x4, x8
	CPRI	CPRI x1, x2, x4, x5, x8, x10, x16
	Fiber Channel	1/ 2/4/8/10/16 GFC
Regeneration	Re-Amplification, Re-Shaping, Re-Timing	

Indication	LED	Power, System, Mode, Test, FX1 Link, FX2 Link, FX3 Link, FX4 Link
Power	Input	12V / 1A
	Power Consumption	< 8W
Size	Dimensions	Card: 155 x 20.8 x 88mm (D x W x H)
	Weight	150g
Environment	Operating Temperature	0 ~ 50°C
	Storage Temperature	-10 ~ 70°C
	Humidity	10 ~ 90%
	Certification	CE, FCC
	MTBF	65000 hrs

Application

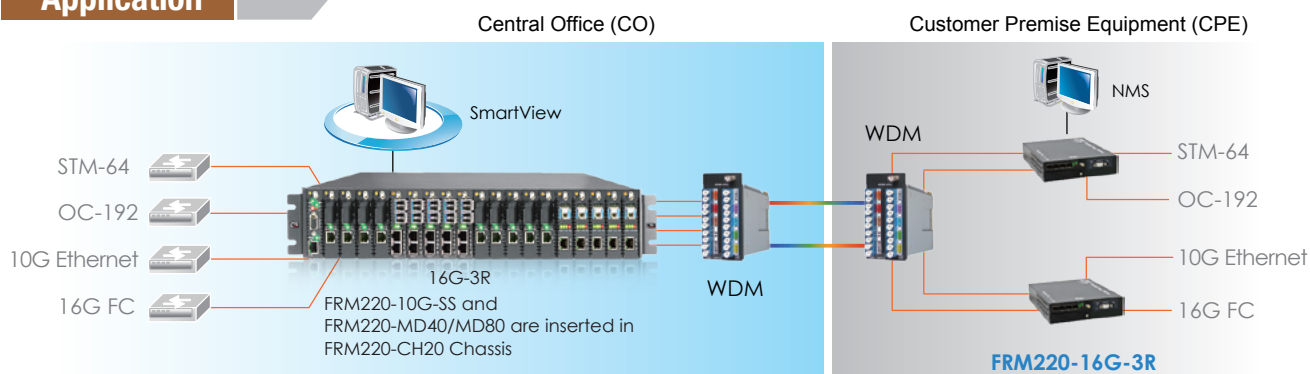

Ordering Information

Model Name	Description
FRM220-16G-3R	2 Channels 16Gbps 3R multi-rate transponder (optional SFP+)

Accessories

10G SFP+ Transceiver Module

SFM-1000-SR85	10G SFP+ SR/SW MMF 300m, 850nm VCSEL, 10G Ethernet/FC/SDH/SONET
SFS-1010-LR31	10G SFP+ LR/LW SMF 10km, 1310nm DFB DML, 10G Ethernet/FC/SDH/SONET
SFS-1040-ER55	10G SFP+ ER/EW SMF 40km, 1550nm DFB EML, 10G Ethernet/FC/SDH/SONET
SFS-1080-ZR55	10G SFP+ ZR/EW SMF 80km, 1550nm DFB EML, 10G Ethernet/FC/SDH/SONET

Note: This card may be placed in CH02M, CH01M or CH04A chassis with fan. For SNMP management, place this card in CH02/NMC or CH04A Chassis.

NEW



FRM220-10G-FEC

10G Ethernet FEC Multi-rate Transponder

FRM220-10G-FEC is a conversion module suitable for high-speed 10G signals with Forward-Error-Correction (FEC). The module supports four flexible SFP+ ports suitable for wavelength conversion and the transferring application for 10GbE and STM-64. The main field of FRM220-10G-FEC application is cost-optimized CWDM and DWDM networks. As an intelligent transponder module, the FRM220-10G-FEC converts a transparent data channel to a corresponding CWDM/DWDM wavelength. By means of the implemented 3R functionality (re-amplification, re-shaping, re-timing) for signal processing, the module is also suited for the use as a repeater. The data rates between 9.95Gbps and 11.32Gbps can be provided. Two types of housings are available for installation in a 19" FRM220 chassis. 20 slots are provided by using the FRM220-CH20 chassis 2U while the FRM220-CH08 1U supports up to 8 modules. Both housings can be monitored and configured through SNMP, Web GUI or Telnet using a NMC management module.

Feature

- Protocol transparent (9.95 – 11.32Gbps)
- 10Gbps signal repeating for 10GbE and STM-64
- 10Gbps conversion: Multimode, Single mode, CWDM, DWDM
- Future-proof and flexible SFP+ technology
- 3R functionality (Re-amplification, Re-shaping and Re-clocking)
- Low power consumption
- Wide range of applications
 - Dual OTN transponder or OTN repeater
 - Lambda conversion with FEC exchange
- Multiple clients data rate support
 - 10G Ethernet LAN/WAN PHY
 - 10G OC-192/ STM-64 SONET/SDH*
- Non OTN/FEC
 - 10G Ethernet LAN-PHY to LAN-PHY
 - 10G Ethernet LAN-PHY to WAN-PHY
- Per interface Forward Error Correction (FEC) encoding selection:
 - ITU-T G.709 Standard RS(255,239) (GFEC) – 6.2 dB
 - ITU-T G.975.1 Section I.7 Ultra-strong FEC with scaled - overhead (UFEC 7%) – 8.1 dB
 - ITU-T G.975.1 Section I.4 Ultra-strong FEC with scaled - overhead (UFEC 10%) – 8.3 dB
 - Zero FEC (wrapper done, FEC is zero)
 - No FEC (wrapper done, FEC is disabled)
- Comprehensive access performance monitoring
 - 10G Ethernet, 10G SONET/SDH*
- Comprehensive G.709 line and service performance monitoring
- Connection testing tools
 - Loopback
 - Notification or fault propagation
- SNMP management through NMC management module
- SFP+ transceivers for flexible configuration including DWDM
- SFP+ Digital Diagnostics

Specifications

General	1-slot module for integration in a FRM220 platform Operating temperature: 0°C – 40°C Dimensions (D x W x H): 155 x 88 x 23mm	Management	SNMP, Telnet and Web management using a NMC management module SFP+ management information provided by integrated DMI functions: input/output power, wavelength, bit rate, status, supported protocols, temperature
Interfaces	4x SFP+ ports (1 x line, 1 x client) Protocol : STM-64, 10G Ethernet Data rate: 9.92Gbps – 11.32Gbps depending on SFP+ type and application used	Housing Types	FRM220-CH08 1U 8-slot chassis FRM220-CH20 2U 20-slot chassis FRM220-CH02M, FRM220-CH02/NMC, 2-slot chassis
SFP+ Types	Optical (LC) 10Gigabit Ethernet (with or without FEC) STM-64 (with or without FEC) Multi-rate for 10Gigabit, STM-64 Wavelengths: 850nm, 1310nm, 1550nm, DWDM or tunable optics		

10G FEC Transponder

Application

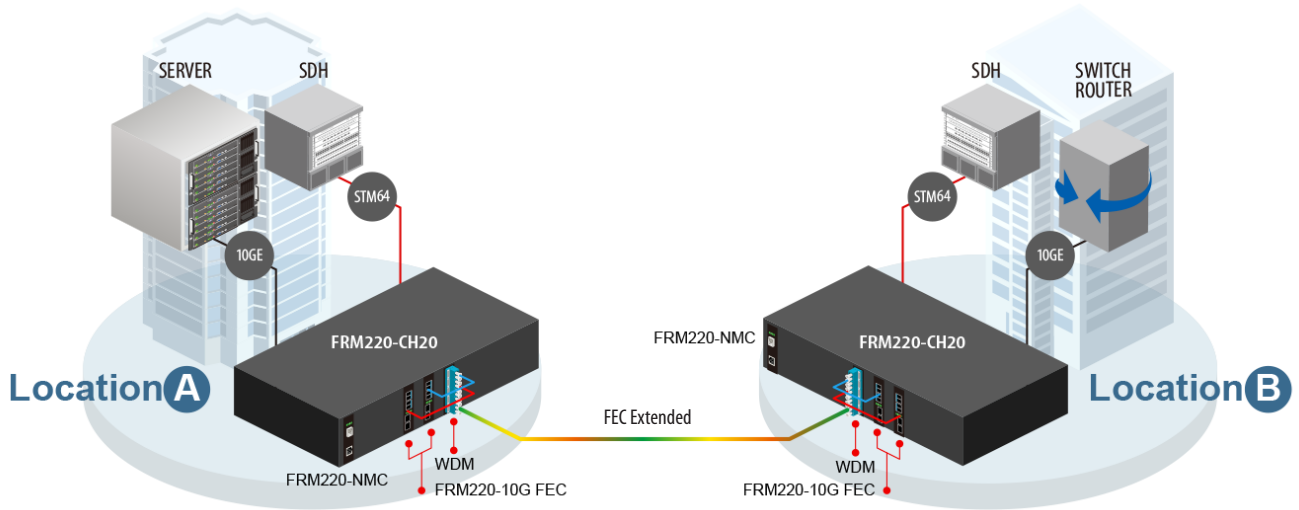

Ordering Information

Model Name	Description
FRM220-10G-FEC	10G Ethernet FEC Transponder

Note: This card MUST be placed in CH02M chassis with fan.
For SNMP management, place this card in CH02/NMC or CH04A Chassis.



FRM220-10G-SXX

10G 3R Multi-rate Transponder with Optical Line Protection

The FRM220-10G-SXX is a 10G fiber to fiber 3R repeater and transponder. Based on 10 Gigabit fiber standards, this transponder supports SFP+ to XFP (SX) or XFP to XFP (XX) fiber connections. 1+1 Automatic optical line Protection Switching is supported for the aggregate XFP fiber ports. The transponder is protocol transparent, providing 3R (Re-amplification, Re-shaping and Re-clocking) between these different optical module types. One of the major applications for this converter is in connecting proprietary transceiver equipment to CWDM or DWDM when these 'colored' optical modules are not available for the proprietary equipment. With transparent bi-directional forwarding capability between the 2 fiber media, the FRM220-10G-SXX brings you the best and simplest solution for your 10G conversion between fiber and fiber.

Feature

- Protocols Transparent at discrete bit rates of 1Gbps to 10Gbps
- Network management via Web, Telnet, SNMP in central FRM220-CH20 chassis (10 cards in chassis max.)
- Protocol transparent 3R fiber media transponder / repeater (Re-amplification, Re-shaping and Re-clocking)
- Promotes flexibility and eases management with pluggable SFP+ or XFP transceiver
- Features two 10G ports offering multiservice 10G transponder and regenerator function
- Supports 1+1 optical line protection
- Built-in self test (BIST) function
- Provides superior optics capabilities resulting in extended transport distances for regional application.
- Extend 10G Ethernet transmission over fiber useful as a 'Transponder' in CWDM or DWDM systems for 10G Ethernet/ Fiber Channel/STM-64
- Supports Client / Line loop back tests
- Serial console for stand-alone management when inserted in CH02M dual slot chassis
- XFP power supplies: +5.0V, -5.2V, +3.3V and +1.8V
- Supports reference clock output
- Supports 10G Tunable XFP module

Specifications

Optical Interface	Connector	LC	Power Input	12VDC
		1x Line SFP+ to 2x Client XFP 1x Line SFP+ to 1x Client XFP 1x Line XFP to 1x Client XFP		Power
	Protocol	OC-192/STM-64 (9.95328Gbps)	Consumption	
		1 Gigabit Ethernet (1.25Gbps) 10 Gigabit Ethernet LAN(10.3125Gbps) G.709 OTU2 (10.709225Gbps) Fiber Channel 1x FC(1.062 Gbps); 2x FC(2.125 Gbps); 4x FC(4.25 Gbps); 8x FC(8.5 Gbps); 10xFC(10 Gbps)	Dimensions	Card: 155 x 20.8 x 88mm (D x W x H)
	Regeneration	Re-amplification Re-shaping, Re-timing	Weight	150g
Power	Loopback	Line / Client	Temperature	0 ~ 50°C (Operating), -10 ~ 70°C (Storage)
	Fiber	SM 9/125µm MM 50/125µm or 62.5/125µm	Humidity	10 ~ 90% non-condensing
	Wavelength	Depends on SFP+ or XFP	Certification	CE, FCC
Indications	LED (Power, Line Link, Client Link, Test, Loop back, Port Active, Alarm)		MTBF	65,000 hrs

Application

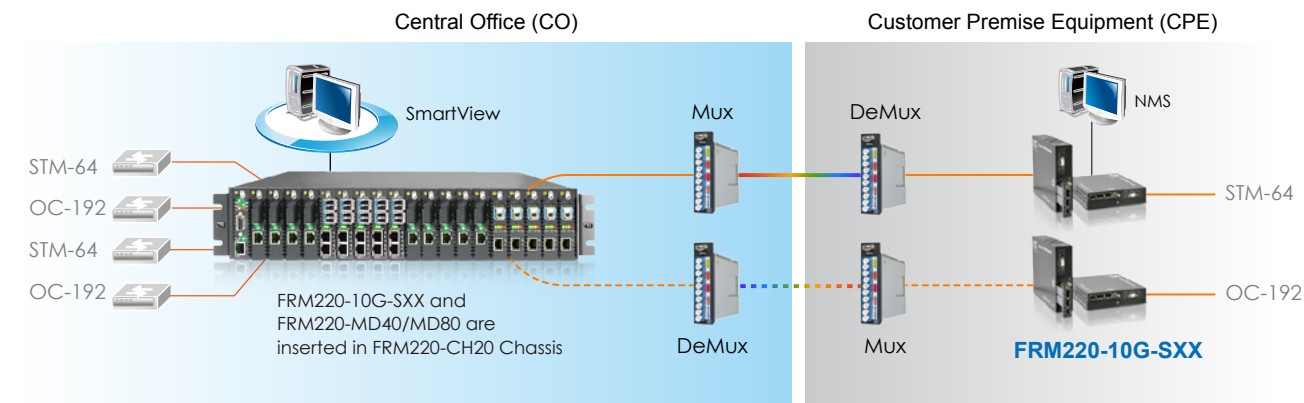

Ordering Information

Model Name	Description
FRM220-10G-SXX	10G 3R SFP+ to XFP fiber protection (optional SFP+, XFP module)

Accessories

10G XFP Transceiver Module

XFM-1000-SR85	10G XFP SR/SW MMF 300m, 850nm VCSEL, Ethernet / Fiber Channel only
XFS-1010-LR31	10G XFP LR/LW SMF 10km, 1310nm DFB DML, Ethernet/Fiber Channel/SDH/SONET
XFS-1040-ER55	10G XFP ER/EW SMF 40km, 1550nm DFB EML, Ethernet/Fiber Channel/SDH/SONET
XFS-1080-ZR55	10G XFP ZR/ZW SMF 80km, 1550nm DFB EML APD, Ethernet/Fiber Channel/SDH/SONET

10G SFP+ Transceiver Module

SFM-1000-SR85	10G SFP+ SR/SW MMF 300m, 850nm VCSEL, 10G Ethernet/FC/SDH/SONET
SFS-1010-LR31	10G SFP+ LR/LW SMF 10km, 1310nm DFB DML, 10G Ethernet/FC/SDH/SONET
SFS-1040-ER55	10G SFP+ ER/EW SMF 40km, 1550nm DFB EML, 10G Ethernet/FC/SDH/SONET
SFS-1080-ZR55	10G SFP+ ZR/EW SMF 80km, 1550nm DFB EML, 10G Ethernet/FC/SDH/SONET

Note: This card may be placed in CH02M or CH04A chassis with fan.
For standalone SNMP management, place this card in CH02/NMC or CH04A chassis.



FRM220-10G-SS

10G 3R Multi-rate Transponder

2

10G Transponder

The FRM220-10G-SS is a 10G fiber to fiber 3R repeater and transponder. Based on a number of 10 Gigabit Fiber standards, these transponders support SFP+ to SFP+ (SS) fiber connections. The transponders are protocol transparent, providing 3R (Re-amplification, Re-shaping and Re-clocking) regeneration between these different optical module types. One of the major applications for this converter is in connecting proprietary transceiver equipment to CWDM or DWDM when these 'colored' optical modules are not available for the proprietary equipment. With transparent bi-directional forwarding capability between the 2 fiber media, the FRM220-10G-SS brings you the best and simplest solution for your 10G conversion between fiber and fiber.

Feature

- Protocols Transparent at discrete bit rates of 1Gbps to 10Gbps
- Network management via Web, Telnet, SNMP in central FRM220 chassis(10 cards in chassis max.)
- Protocol transparent 3R fiber media transponder / repeater (Re-amplification, Re-shaping and Re-clocking)
- Promotes flexibility and eases management with pluggable SFP+ transceiver
- Features two 10G ports offering multiservice 10G transponder and regenerator function
- Provides superior optics capabilities resulting in extended transport distances for regional application.
- Extend 10G Ethernet transmission over fiber
- Useful as a 'Transponder' in CWDM or DWDM systems for 10G Ethernet/Fiber Channel/STM-64
- Supports Client / Line loop back tests
- Serial console for stand-alone management when inserted in CH02M Single Slot Chassis
- SFP+ power supplies: +3.3V

Specifications

Optical Interface	Connector	LC, 1x Line SFP+ to 1x Client SFP+	Power Input	12VDC							
	Protocol	OC-192/STM-64 (9.95328Gbps)		Power Consumption	< 12W						
		10 Gigabit Ethernet			Dimensions	Card: 155 x 20.8 x 88mm (D x W x H)					
		LAN(10.3125Gbps)				Weight	150g				
		G.709 OTU2 (10.709225Gbps)					Temperature	0 ~ 50°C (Operating), -10 ~ 70°C (Storage)			
		Fiber Channel						Humidity	10 ~ 90% non-condensing		
		1xFC (1.062 Gbps); 2xFC (2.125 Gbps)							Certification	CE, FCC	
		4xFC (4.25 Gbps); 8xFC (8.5 Gbps)								MTBF	65,000 hrs
		10xFC (10.51875 Gbps)									
		Regeneration									Re-amplification
		Re-shaping, Re-timing									
	Loopback	Line / Client									
	Fiber	SM 9/125µm									
		MM 50/125µm or 62.5/125µm									
Optical Interface	Wavelength	CWDM 1470 ~ 1610nm									
		DWDM 1529.55 ~ 1565.50nm									
Indications	LED (Power, Line Link, Client Link, Test, Loop back, Port Active, Alarm)										

10G Transponder

Application

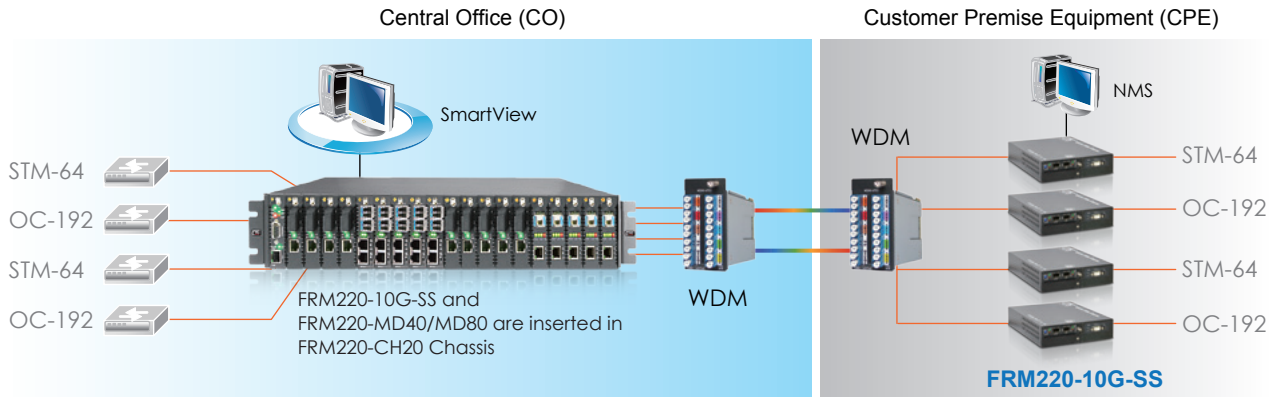

Ordering Information

Model Name	Description
FRM220-10G-SS	10G 3R transponder, SFP+ to SFP+ (optional SFP+ module)

Accessories

10G SFP+ Transceiver Module

SFM-1000-SR85	10G SFP+ SR/SW MMF 300m, 850nm VCSEL, 10G Ethernet/FC/SDH/SONET
SFS-1010-LR31	10G SFP+ LR/LW SMF 10km, 1310nm DFB DML, 10G Ethernet/FC/SDH/SONET
SFS-1040-ER55	10G SFP+ ER/EW SMF 40km, 1550nm DFB EML, 10G Ethernet/FC/SDH/SONET
SFS-1080-ZR55	10G SFP+ ZR/EW SMF 80km, 1550nm DFB EML, 10G Ethernet/FC/SDH/SONET

Note: This card may be set by DIP switch or console, but **MUST** be placed in CH02M chassis with fan. For SNMP management, place this card in CH02/NMC or CH04A Chassis.



FRM220-4G-3S

4G 2R Multi-rate Transponder with Optical Line Protection

The FRM220-4G-3S is a 2R 4G optical regeneration device, which consists of Re-amplification and Re-shaping. The transponder card converts a data signal to the correct wavelength for transmission on a specific channel by supporting SFP optics on both line side and client side interfaces. 1+1 Automatic optical line Protection Switching is supported for the aggregate fiber ports. When the FRM220-4G-3S card is placed in the FRM220 rack with SNMP management, the management can view the converter card's status, type, version, fiber link status and alarms. The card can be configured to enable or disable the port, reset the port and perform diagnostic loop backs.

Feature

- Multi-rate supports 28Mbps to 4.25Gbps
- Network management via Web, Telnet, SNMP in central FRM220 chassis
- Local configuration via DB9 console port (when placed in CH01M or CH02M)
- Digital diagnostic monitoring of SFP module
- Perform optical repeater function (Re-amplification, Re-shaping)
- Facility loopback on both Client / Line sides
- 1+1 optic fiber protection
- Link Fault Pass-Through (LFPT)
- Auto Laser Shutdown (ALS)
- Detect transceiver transmitter error alarm

Specifications

Optical Interface	Connector	SFP LC
	Protocol	OC -3, OC -6, OC -12, STM-1, STM-4, STM-16, FC -1, FC -2, FC -4
	Regeneration	Re-amplification Re-shaping
	Loop back	Line/Client
	Fiber	MM 62.2/125μm, 50/125μm. SM 9/125μm
	Wavelength	MM 850, 1310nm SM 1310, 1550nm WDM 1310T/1550R, 1550T/1310R CWDM 1470 ~ 1610nm
	Indications	LED (PWR, Line Link, Client Link, Test, Loop back, Port Active, Alarm)
Power Input	12VDC	
Power Consumption	< 12W	

Dimensions	Card: 155 x 20.8 x 88mm (D x W x H)
Weight	120g
Temperature	0 ~ 50°C (Operating), -10 ~ 70°C (Storage)
Humidity	10 ~ 90% non-condensing
Certification	CE, FCC
MTBF	65,000 hrs

Application

Managed 4G 2R Transponder with Fiber Protection

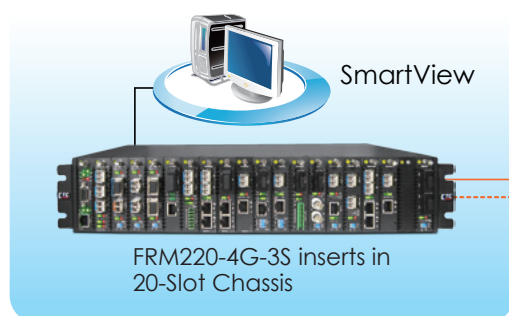

1+1 Fiber Protection



Protocols: Fast Ethernet, Gigabit Ethernet, OC-3, OC-6, OC-12, STM-1, STM-4, STM-16, FC-1, FC-2

4G Transponder

Ordering Information

Model Name	Description
FRM220-4G-3S	4G 2R Transponder with fiber protection, (optional SFP module)

Accessories

Multi-Mode 1.25Gbps SFP

SFM-7000-S85	1.25G SX, MM, 550m, 850nm, 8.5dB, 3.3V, LC
SFM-7000-S85-DD	1.25G SX, MM, 550m, 850nm, 8.5dB, 3.3V, LC, DD
SFM-7000-L31	1.25G LX, MM, 2km, 1310nm, 10dB, 3.3V, LC
SFM-7000-L31-DD	1.25G LX, MM, 2km, 1310nm, 10dB, 3.3V, LC, DD

Single-Mode 1.25Gbps SFP

SFS-7020-L31	1.25G LX, SM, 20km, 1310nm, 15dB, 3.3V, LC
SFS-7020-L31-DD	1.25G LX, SM, 20km, 1310nm, 15dB, 3.3V, LC, DD
SFS-7040-L31	1.25G LX, SM, 40km, 1310nm, 20dB, 3.3V, LC, DFB LD
SFS-7040-L31-DD	1.25G LX, SM, 40km, 1310nm, 20dB, 3.3V, LC, DFB LD, DD

Single Fiber 1.25Gbps SFP

SFS-7020-WA	1.25G WDM, 20km, Tx1310nm / Rx1550nm (A type), 3.3V, LC
SFS-7020-WA-DD	1.25G WDM, 20km, Tx1310nm / Rx1550nm (A type), 3.3V, LC, DD
SFS-7020-WB	1.25G WDM, 20km, Tx1550nm / Rx1310nm (B type), 3.3V, LC
SFS-7020-WB-DD	1.25G WDM, 20km, Tx1550nm / Rx1310nm (B type), 3.3V, LC, DD
SFS-7040-WA	1.25G WDM, 40km, Tx1310nm / Rx1550nm (A type), 3.3V, LC
SFS-7040-WA-DD	1.25G WDM, 40km, Tx1310nm / Rx1550nm (A type), 3.3V, LC, DD
SFS-7040-WB	1.25G WDM, 40km, Tx1550nm / Rx1310nm (B type), 3.3V, LC
SFS-7040-WB-DD	1.25G WDM, 40km, Tx1550nm / Rx1310nm (B type), 3.3V, LC, DD

Note: This card may be set by DIP switch and placed in CH02M chassis with fan, or set by serial console if placed in CH01M chassis



FRM220-2.7G-3S

2.7G Transponder (3R) with Optical Line Protection

The FRM220-2.7G-3S is a 3R 2.7G optical repeater and transponder, which consists of Re-amplification, Re-shaping and Re-timing. The transponder card converts a data signal to the correct wavelength for transmission on a specific channel by supporting SFP optics on both line side and client side interfaces. 1+1 Automatic optical line Protection Switching are supported for the aggregate fiber ports. When the FRM220-2.7G-3S card is placed in the FRM220 rack with SNMP management, the management can view the converter card's status, type, version, fiber link status and alarms. The card can be configured to enable or disable the port, reset the port and set the desired data rate to match the transmitted protocol.

Feature

- Multi-rate supports 34.3Mbps to 2.7Gbps
- Network management via Web, Telnet, SNMP in central FRM220 chassis
- Link Fault Pass-Through (LFPT)
- Auto Laser Shutdown (ALS)
- Local configuration via DB9 craft port In Stand-alone
- Digital diagnostic monitoring of SFP module
- Perform optical repeater function (Re-amplification, Re-shaping, and Re-clocking)
- Facility loopback on both Client / Line sides
- 1+1 optic fiber protection
- Dip switch setting data rate
- Detect transceiver transmitter error alarm

Specifications

Optical Interface	Connector	SFP LC	Indications	LED (PWR, Line Link, Client Link, Test, Loop back, Port Active, Alarm)	
	Protocol	OC -3, OC -6, OC -12, OC-24, OC-48, STM-1, STM-4, STM-16, FC -1, FC -2		Power Input	12VDC
Regeneration	Re-amplification	Loop back	Line/Client	Power Consumption	< 12W
	Re-shaping		Fiber	Dimensions	Card: 155 x 20.8 x 88mm (D x W x H)
	Re-clocking		MM 62.2/125μm, 50/125μm SM 9/125μm	Weight	120g
Wavelength	MM 850, 1310nm SM 1310, 1550nm WDM 1310T/1550R, 1550T/1310R CWDM 1470 ~ 1610nm		Temperature	0 ~ 50°C (Operating), -10 ~ 70°C (Storage)	
			Humidity	10 ~ 90% non-condensing	
			Certification	CE, FCC	
			MTBF	65,000 hrs	

Application

Managed 2.7G 3R Transponder with Fiber Protection

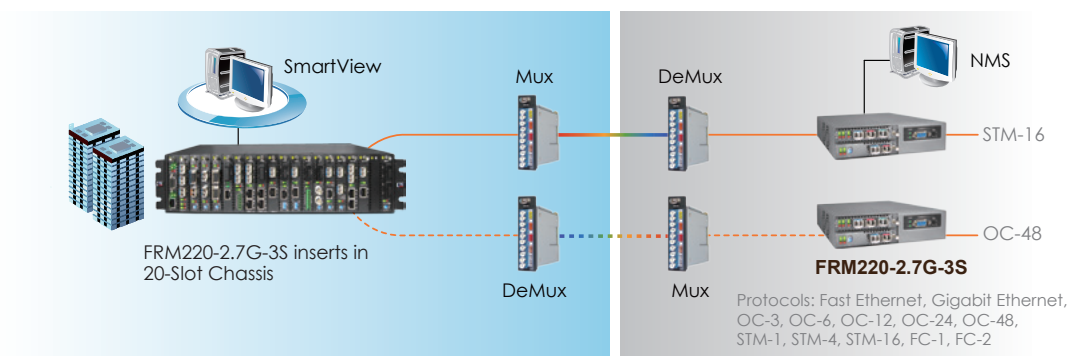

Ordering Information

Model Name	Description
FRM220-2.7G-3S	2.7G 3R Transponder with fiber protection, (optional SFP module)

Multi-Rate 2.67G SFP Module

SFM-9000-S85-DD	2.67G SX, MM, 300m, 850nm, 3.3V, LC, VCSEL (DD)
SFS-9002-L31-DD	2.67G LX, SM, 2km, 1310nm, 11dB, 3.3V, LC, FP (DD)
SFS-9015-L31-DD	2.67G LX, SM, 15km, 1310nm, 15dB, 3.3V, LC, DFB (DD)
SFS-9030-Z55-DD	2.67G ZX, SM, 30km, 1550nm, 15dB, 3.3V, LC, DFB (DD)
SFS-9050-Z55-DD	2.67G ZX, SM, 50km, 1550nm, 20dB, 3.3V, LC, DFB (DD)
SFS-9080-Z55-DD	1.25G WDM, 40km, Tx1310nm / Rx1550nm (A type), 3.3V, LC, DD
SFS-9100-Z55-DD	2.67G ZX, SM, 100km, 1550nm, 30dB, 3.3V, DFB (DD)

Note: This card may be set by DIP switch or console, but **MUST** be placed in CH02M chassis with fan. For SNMP management, place this card in CH02/NMC or CH04A Chassis.

NEW



FRM220-OAB15

Single Channel EDFA Booster NIC

The FRM220-OAB15 is a FRM220 chassis rack managed single channel Erbium Doped Fiber Amplifier (EDFA) booster line card for C-band. It has a large dynamic range while providing excellent broadband noise performance. It provides Automatic constant output Power Control (APC) and Automatic Constant Current (ACC) via rack management or RS-232 console interface. Its fast transient suppression feature allowing the output power to be kept constant level when there are fast changes in input power.

Feature

- Single channel EDFA with FRM220 chassis rack management
- Up to 15 dBm output power
- Output level constant control mode
- Output current constant control mode
- Low noise figure
- Low power dissipation

Applications

Booster Amplifier for 10Gbps, 40Gbps, and 100Gbps applications
Long haul C-band DWDM applications

Specifications

Parameter	Units	Specifications		Remarks
		Min.	Max.	
Wavelength Bandwidth	nm	1528	1562	
Input Power Range	dBm	-10	0	
Output Power Range	dBm		+15	@ Input Power = -6~0dBm
Noise Figure	dB		7.0	@ -6dBm input with 16dB gain
PDG	dB		0.5	
PMD	ps		0.5	
Power Consumption	W		2	
Operation Temperature	Degree C	-5	+70	
Storage Temperature	Degree C	-20	+70	
Transportation Temperature	Degree C	-40	+85	72 hrs max.
Dimensions	mm	155 x 88 x 23mm		

Application

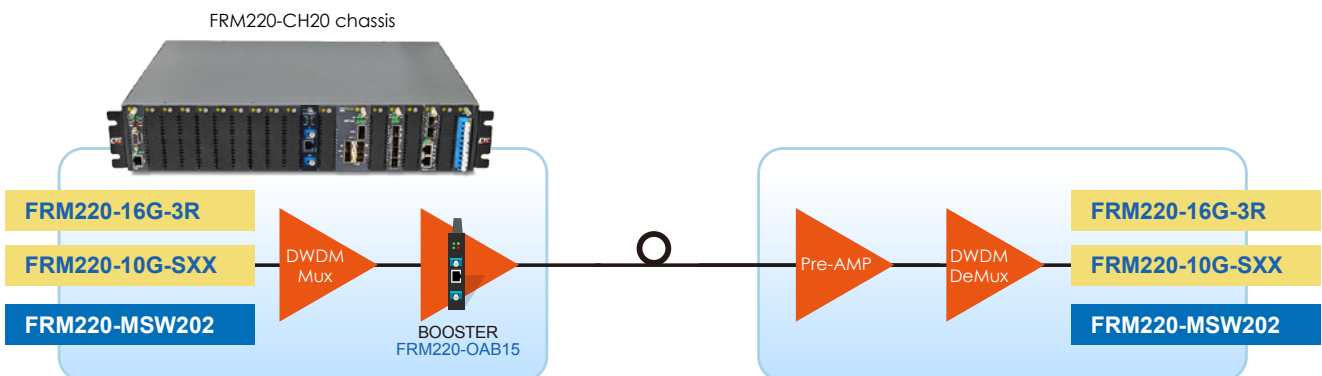

Ordering Information

Model Name	Description
FRM220-OAB15	FRM220 Chassis Single Channel EDFA Booster NIC

Naming Rule

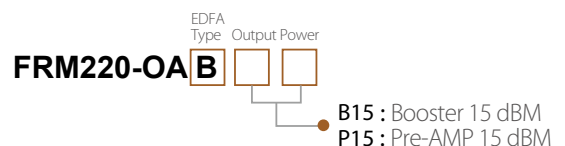



FRM220-DWDM

DWDM Mux/DeMUX

CTC Union DWDM MUX DEMUX Modules, with 100GHz channel spacing, can be used to combine or separate wavelength channels at standard ITU grid. We supply the common configuration including 4, 8, 16 channels. These DWDM modules passively multiplex the optical signal outputs from 4 or more electronic devices, and send them over a single optical fiber and then de-multiplex the signals into separate, distinct signals for input into electronic devices at the other end of the fiber optic link. All the DWDM MUX DEMUX modules provide excellent optical performance and high reliability to ease of fiber handling and power saving solution.

Feature

- Low Optical Insertion Loss
- High channel isolation
- Low PDL
- Good channel-to-channel uniformity
- Exceptional reliability and stability
- Reliable passive WDM optical technology
- Scales easily for ring networks
- Compliance with RoHS

Specifications

Item	100GHz DWDM	
	Mux	DeMux
Type		
Channel No.	4 / 8 / 16	
Center Wavelength, nm	Ch 21~60 or ITU Standard (specity)	
Channel Spacing, nm	0.8	
Channel Spacing, GHz	100	
Passband @0.5dB, nm	ITU ± 0.1	
Insertion Loss, dB for 4 channel	≤2.0	
Insertion Loss, dB for 8 channel	≤3.5	
Insertion Loss, dB for 16 channel	≤4.5	
Adjacent Channel Isolation, dB	N/A	≥25
Non-adjacent Channel Isolation, dB	N/A	≥35
Uniformity, dB	≤1.5 (Mux-DeMux Pair only)	
Directivity, dB	≥45	
Optical Input Return Loss, dB	≥45	
Polarization Dependent Loss, dB	≤0.15	
Polarization Mode Dispersion (PMD), ps	≤0.1	
Thermal Stability Drift, pm/°C	≤1	
Max. Optical Power, mW	300	
Max. Tensile Load, N	5	
Storage Temperature, °C	-40~85	
Operating Temperature, °C	0~70	

Application

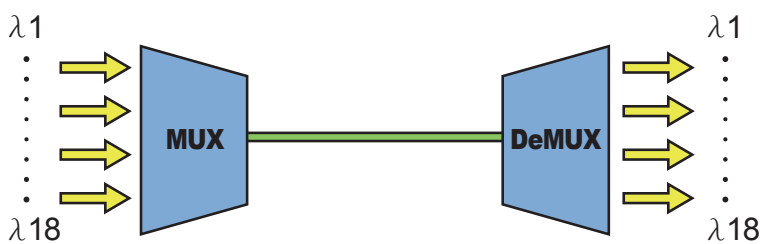

DWDM MUX must be used with DEDMUX on the other side

- Access networks
- Metro WDM systems
- Long haul WDM systems
- Enterprise networks
- Telecommunication
- Cellular Application
- Fiber optical amplifier
- Metro Network /Access Network/FTTH
- CATV fiber optic links

Ordering Information

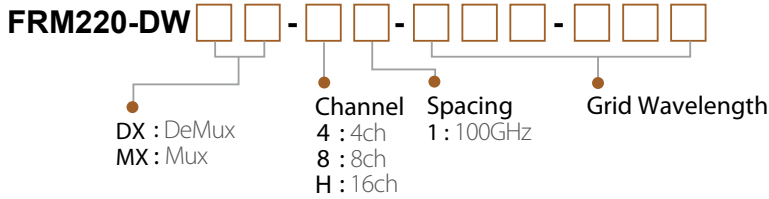

Model Name	Description
FRM220-DWab-cd-xxx-xxx	ab → DX : DeMux, MX : Mux c → 4 : 4ch, 8 : 8ch, H : 16ch d → 1 : 100GHz xxx → Grid wavelength

Please select all that apply from below list

100GHz Grid Wavelength

- D21 D22 D23 D24 D25 D26 D27 D28 D29 D30
 D31 D32 D33 D34 D35 D36 D37 D38 D39 D40
 D41 D42 D43 D44 D45 D46 D47 D48 D49 D50
 D51 D52 D53 D54 D55 D56 D57 D58 D59 D60

100GHz Grid Wavelength

Label	Frequency (THz)	Center Wavelength (nm)
D21	192.1	1560.61
D22	192.2	1559.79
D23	192.3	1558.98
D24	192.4	1558.17
D25	192.5	1557.36
D26	192.6	1556.55
D27	192.7	1555.75
D28	192.8	1554.94
D29	192.9	1554.13
D30	193.0	1553.33
D31	193.1	1552.52
D32	193.2	1551.72
D33	193.3	1550.92
D34	193.4	1550.12
D35	193.5	1549.32
D36	193.6	1548.51
D37	193.7	1547.72
D38	193.8	1546.92
D39	193.9	1546.12
D40	194.0	1545.32

D41	194.1	1544.53
D42	194.2	1543.73
D43	194.3	1542.94
D44	194.4	1542.14
D45	194.5	1541.35
D46	194.6	1540.56
D47	194.7	1539.77
D48	194.8	1538.98
D49	194.9	1538.19
D50	195.0	1537.40
D51	195.1	1536.61
D52	195.2	1635.82
D53	195.3	1535.04
D54	195.4	1534.25
D55	195.5	1533.47
D56	195.6	1532.68
D57	195.7	1531.90
D58	195.8	1531.12
D59	195.9	1530.33
D60	196.0	1529.55



Order Form

Example:

FRM220-DW - 4 - 1 - D 2 - 1 - D 2 4

↳ DWDM, Mux, 4 channels, 100GHz, 1560.61, 1559.79, 1558.98, 1558.17 Grid Wavelength

FRM220-DW - - - - - - - - - -



Order Form

Example:

4ch:

FRM220-CW **M** **D** - **4** **2** - **A** **B** **C** **D**

↳ CWDM, Mux/DeMux, 4 channels, 1x upgrade port, 1271, 1291, 1311, 1331 Wavelength

FRM220-CW - -

8ch:

FRM220-CW **D** **X** - **8** **0** - **A** **B** **C** **D** **I** **J** **K** **L**

↳ CWDM, DeMux, 8 channels, Dual Fiber, 1271, 1291, 1311, 1331, 1471, 1491, 1511, 1531 Wavelength

FRM220-CW - -

16ch:

FRM220-CW **M** **X** - **H** **1** - **Z**

↳ CWDM, Mux, 16 channels, monitor port, 1271~1611 Wavelength

FRM220-CW - -

Please select all that apply from below list

A 1271 **B** 1291 **C** 1311 **D** 1331

E 1351 **F** 1371 **G** 1431 **H** 1451

I 1471 **J** 1491 **K** 1511 **L** 1531

M 1551 **N** 1571 **O** 1591 **P** 1611

.....
 Z All Wavelengths

NEW



FRM220-OPS51 FRM220-OPS52

Fiber Optical Protection Switch

2

Optical Protection Switch

FRM220-OPS Series are able to provide fiber path redundancy on a channel by channel basis. These units are particularly well suited for protection in any type of fiber data transmission. This solution includes monitoring capabilities for both the working and protected path fibers. In case of a fiber cut in the active path, traffic will be switched over to the protected path in less than 50ms (FRM220-OPS51) or 20ms (FRM220-OPS52). Monitoring is available through SNMP Management when both card is placed in FRM220 rack with SNMP management. The management can view the converter card's status, type, version, fiber link status and alarms. The card can be configured to enable or disable the port, reset the port, and configure receive threshold levels for path switching.

Feature

- Latch feature, if power is lost the switch remains in its current state
- Protection transition < 50 ms (FRM220-OPS51)
- Protection transition < 20 ms (FRM220-OPS52)
- Works with any combination of 1 ~16 wavelengths
- Traffic is switched in one of three modes : revertive,non-revertive, manual
- Programmable Rx threshold setting for switch-over
- Optical Interface Type : LC connectors
- Working and protected lines are physically separated fiber

Specifications

Connector	LC
LEDs	Power System, Working Path, Protection Path, Work mode
Power	DC 12V In
Operating Wavelength	1260 ~ 1620
Switch Type	2x1 / Latching
Input Power (Optical)	-35~-5dBm
Accuracy	≤ 0.5dBm
Insertion Loss	≤ 2.5 (Pair) (FRM220-OPS51), ≤ 5.5dB (FRM220-OPS52)
Return Loss	≥ 45dB
Cross-talk	≥ 60dB

Polarization Dependent Loss (PDL)	≤ 0.15dB
Input Power Sensitivity	-35dBm
Restoration Time	≤20ms
Power Consumption	< 6W
Dimensions	Card: 155 x 20.8 x 88mm (D x W x H)
Weight	130g
Temperature	0 ~ 50°C (Operating), -10 ~ 70°C (Storage)
Humidity	10 ~ 90% non-condensing
Certification	CE, FCC
MTBF	65,000 hours

Application

FRM220-OPS51 Working Theory

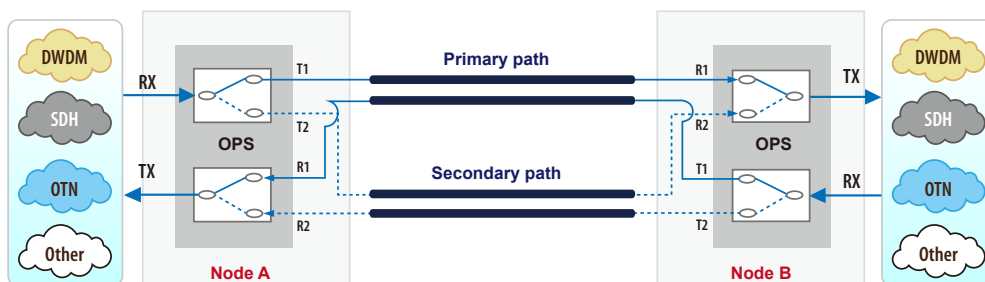

FRM220-OPS52 Working Theory

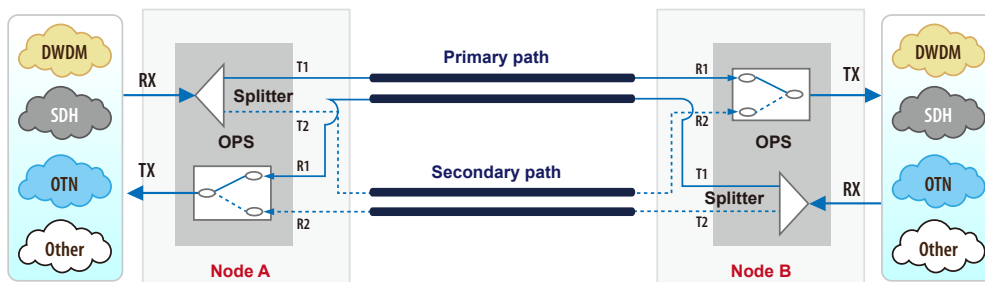

Ordering Information

Model Name	Description
FRM220-OPS51	Fiber Optical Protection Switch with LC/PC connector, OPS module inside
FRM220-OPS52	Fiber Optical Protection Switch with LC/PC connector, splitter inside

Note: This card must use CH01M, with serial console, to configure standalone settings. For SNMP management, place this card in CH02/NMC or CH04A Chassis.

Naming Rule

FRM220-OPS5



- Optical Switch Mode
- 1 : Splitter Inside
- 2 : OPS module inside



FRM220-10GC-TS

10G Base-T to 10G Base-R SFP+ Media Converter

The FRM220-10GC-TS is a copper to fiber 10G Ethernet media converter based on IEEE802.3an and IEEE802.3ae. With SNMP and Web-based management in the FRM220, the Network administrator can monitor, configure and control the activity of each card in the chassis. This converter uses Cat.6a/Cat 7 twisted pair cable as copper transmission media with RJ-45 and 10G optical solution with SFP+ LC connector. The data stream can be converted bi-directionally from 10G Base-T to 10G Base-R and vice versa. With full duplex wire speed forwarding capability between these two media, the FRM220-10GC-TS brings you the best and simplest solution for the 10G Ethernet conversion between copper wire and fiber.

Feature

- Network Management via FRM220 Chassis
- Complies with IEEE802.3an 10GBase-T and IEEE802.3ae 10GBase-R
- Real-Time conversion between 10GBase-T and 10GBase-R
- Common used SFP+ fiber interface and RJ45 connector
- Full duplex wire speed forwarding
- Forwarding 18k bytes jumbo packet
- Loopback Test
- Link Fault Pass Through
- Fiber Fault Alert
- IEEE 802.1q VLAN pass through
- Supports manual Dip Switch for quick set up

Specifications

Optical Interface	Connector	SFP+ LC
	Data rate	10.3125Gbps
	Distance	300m, 10km, 40km, 80km
	Wavelength	1550nm, 1310nm, 850nm, WDM
Electrical Interface	Connector	RJ45
	Data rate	10Gbps
	Cable type	Cat.6a, 7
	Distance	95 meters (Cat.7)
Management	Console port	RS-232 via CH01M, DIP Switch with CH01
Standards	IEEE 802.3an, IEEE 802.3ae	

LEDs	SFP+, LR, Link/Act, LBK A/B, SYS
Power	12VDC
Power Consumption	< 12W
Dimensions	Card: 155 x 20.8 x 88mm (D x W x H)
Weight	130g
Temperature	0 ~ 50°C (Operating), -10 ~ 70°C (Storage)
Humidity	0 ~ 85% non-condensing
Certification	CE, FCC
MTBF	57,000 hrs

Application

Central Office (CO)

Customer Premise Equipment (CPE)

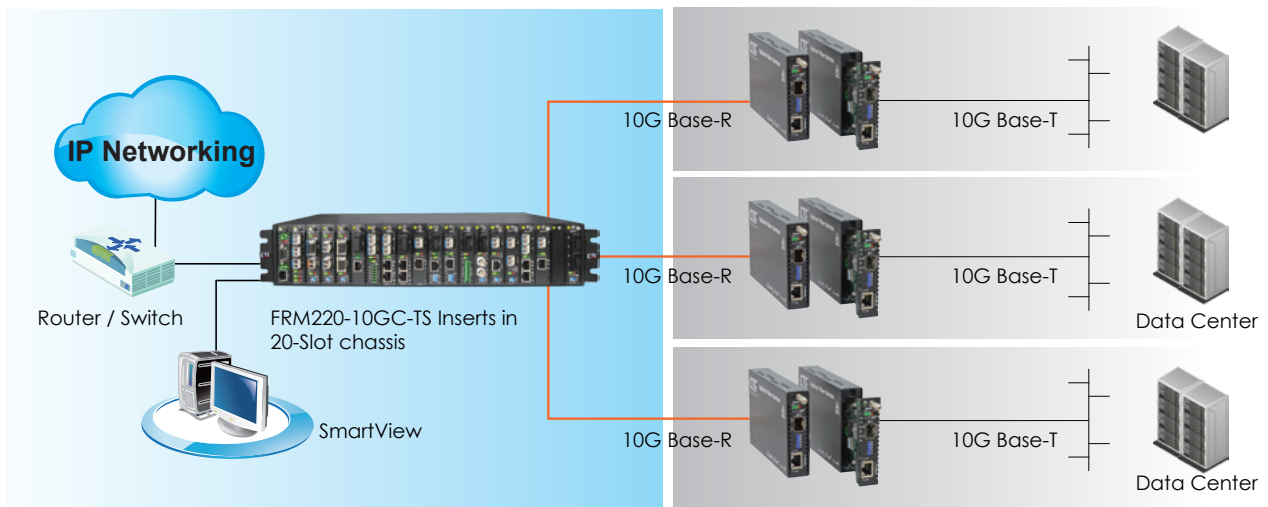

Ordering Information

Model Name	Description
FRM220-10GC-TS	10G Base-T RJ45 to 10G Base-R SFP+, with DIP switch (optional SFP+)



FRM220-MSW404

4x 10/100/1000Base-T + 4x 100/1000Base-X
L2+ Gigabit Carrier Ethernet Switch (NID)

2

Network Interface Device (NID)

The CTC Union's FRM220-MSW404 is the new generation of carrier grade Ethernet demarcation device for business connection and mobile backhaul transportation service delivered by carriers. The FRM220-MSW404 is equipped 4 SFP slots in dual rate 100/1000Base-X and 4 ports 10/100/1000Base-T RJ45 network interfaces. It is designed to enable E-Line, E-LAN, E-Tree services which are CE (Carrier Ethernet) 2.0 compliant for Metro Ethernet network deployments.

The FRM220-MSW404 device enables carriers and service providers to delivered SLA-based network service with extensive fault detection and diagnostic capabilities which are compliant with the latest Ethernet OAM standards such as IEEE 802.3ah, IEEE 802.1ag and ITU-T Y.1731. With built-in RFC2544 feature sets, The FRM220-MSW404 also enables the service providers to perform the SLA verification anytime to ensure the quantitative latency, jitter and throughput delivery performance indexes. The CE2.0 compliant functions support EVCs and 3 colors marker QoS traffic management to enable service providers managing bandwidth and enforce SLA guaranteed. This card may be controlled and monitored via an NMC in a managed chassis or used as a completely manageable device when used stand-alone. Stand-alone management supports Telnet/SSH, HTTP/HTTPS and SNMP v1, v2C or v3.

Feature

- The next generation of Ethernet demarcation device, at customer premise, fulfilling the large-scale carrier Ethernet deployment for intelligent business connection and mobile backhaul services complied to CE 2.0 standard.
- CE2.0 standards compliant product guarantees the fully interoperability with other MEF certified equipment and reduces the risks and cost of Carrier Ethernet network deployment for operators and service providers.

Specifications

Interface	100/1000Mbps SFP slots x 4 + 10/100/1000Base-T RJ45 x 4	SNMP Agent	SNMP v1/v2c/v3, RMON Group 1,2,3 and 9
Filter & Forward Rate	14880pps at 10Mbps, 148800pps at 100Mbps, 1488000pps at 1Gbps	Software Upgrade	TFTP/HTTP
Switching Fabric Capacity	16Gbps	Ethernet OAM	IEEE 802.3ah, IEEE 802.1ag, ITU-T Y.1731, RFC2544
Transmission Method	Store and Forward Switching	LED Display	Power, System, Console, Link, Speed/Act
Standard	IEEE 802.3u, IEEE 802.3z, IEEE 802.3ae, IEEE 802.3x, IEEE 802.1p, IEEE 802.1Q, IEEE 802.1ad, IEEE 802.1D, IEEE 802.1w, IEEE 802.1s, IEEE 802.1x, IEEE 802.3ad	Power Input	100V ~ 240VAC, -18 ~ -72VDC
Packet Buffer	8M bits	Power Consumption	< 20W
MAC Table Size	8K	Operating Temperature	0 ~ 50°C
Max. Packet Size	10K Bytes	Humidity	5% ~ 90% (non-condensing)
VLAN Feature	IEEE 802.1Q tagged VLAN(Max. 4K VLAN groups), port based VLAN, MAC based VLAN, protocol based VLAN, private VLAN, IEEE 802.1ad Q-in-Q, VLAN Translation, GVRP	Dimensions	Card: 155 x 42.1 x 88 mm (D x W x H)
QoS Feature	IEEE 802.1p 8 priority queues per port, CoS based on switch port; VLAN ID; DSCP; TCP/UDP port, IEEE 802.1p priority tag remarking, DSCP remarking, Port based ingress/egress rate limit 3 colors marker-CIR/EIR/Burst bandwidth control	Regulatory	FCC, CE
L2 switching protection	STP, RSTP, MSTP, ITU-T G.8031/G.8032 Ethernet ring protection		
Trunking	IEEE 802.3ad LACP(Max. 4 trunking group, Max. 8 ports per trunking group)		
Security	IEEE 802.1x port based access control, MAC based access control authentication, RADIUS authentication, limited MAC address learning, IP/MAC binding, ACL rule based filtering, TACACS+, IP source guard, DHCP snooping/relay option 82, ARP inspection		
IP Multicasting	IGMP throttling, IGMP filtering, IGMP fast leave, IGMP snooping v1/v2/v3, MVR, MLD snooping v1/v2		
Storm Control	Unicast/Broadcast/Multicast storm suppression		
Management	Web/Telnet CLI/SNMP/console interface, Web/CLI authentication, SSH v2, HTTPS, port mirroring, syslog, IPv6 management, NTP, SNTP		

Application

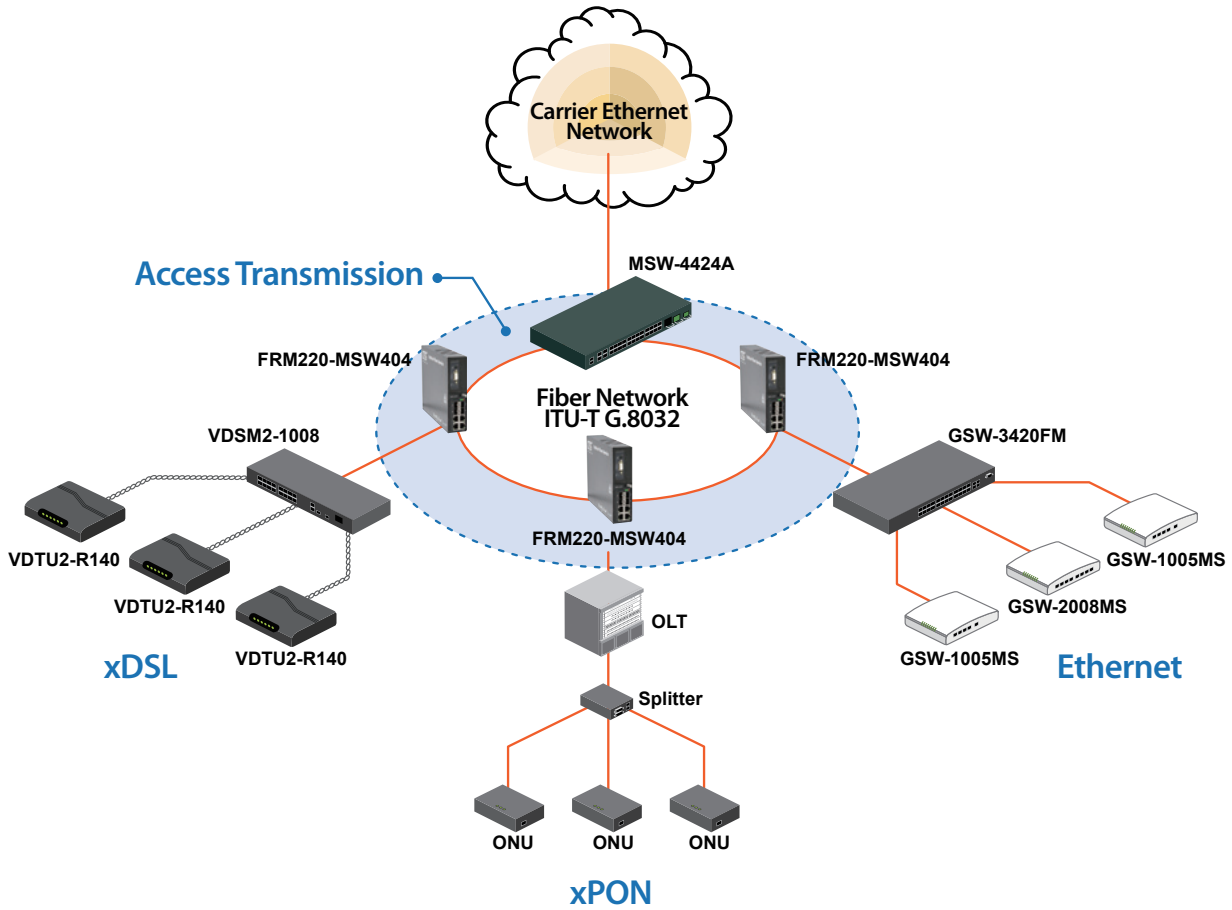

- Carrier Ethernet with multiple class of service
- Traffic Synchronization
- Precisely delivery of time-sensitive service

Ordering Information

Model Name	Description
FRM220-MSW404	4 x SFP Slots in Dual Rate 100/1000Base-X and 4x 10/100/1000Base-T RJ45 OAM Managed Carrier Ethernet Switch

FRM220 – MSW404
 Example: FRM220 – MSW404

Note: To Support Console Interface managed, this card must be placed in CH02M chassis.

- Standalone type is available. Please refer to page :



FRM220-MSW202

2x 10/100/1000Base-T + 2x 100/1000Base-X
L2+ Gigabit Carrier Ethernet Switch (EDD)

FRM220-MSW202 is a carrier class Ethernet Demarcation Device (EDD) with 2 x 10/100/1000Base-T Ethernet ports and 2 x 100/1000Base-X dual rate SFP fiber ports which enables EPL (Ethernet Private Line) & EVPL (Ethernet Virtual Private Line) services with advanced carrier Ethernet features per the Metro Ethernet Forum (MEF 9 and 14). By supporting link and service Ethernet OAM schemes, the FRM220-MSW202 also provides extensive fault detection and diagnostic capabilities to ensure that actual network use complies with pre-agreed service level agreements (SLAs). This card may be controlled and monitored via an NMC in a managed chassis or used as a completely manageable device when used stand-alone. Stand-alone management is supported by Telnet/SSH, HTTP/HTTPS and SNMP v1, v2C or v3.

Feature

- Complies with MEF CE1.0
- Supports 8K MAC
- Spanning Tree 802.1D, 802.1s, 802.1w
- Supports 802.1Q / 4K active VLANs
- Double VLAN Tagging (C-tag/S-tag) (IEEE 802.1ad) support for ISP application
- Various QoS capability (MAC/port/802.1p/Diffserv)
- Port-based rate limiting
- DHCP Snooping
- IGMP Snooping
- IPv6 support
- IEEE 802.3x and IEEE 802.1x support
- Jumbo frame for up to 9.6K
- Extensive Ethernet OAM support
- IEEE 802.3ah, IEEE 802.1ag, ITU-T Y.1731
- SNMP v1/v2c/v3, Telnet, Web GUI
- IEEE 1588 V2 aware (Optional)

Specifications

Interface	100/1000Mbps SFP slots x 2 + 10/100/1000Base-T RJ45 x 2	Management	Web/Telnet CLI/SNMP/console interface, Web/CLI authentication, SSH v2, HTTPs, port mirroring, syslog, IPv6 management, NTP, SNTP, sFlow
Filter & Forward Rate	14880pps at 10Mbps, 148800pps at 100Mbps, 1488000pps at 1Gbps	SNMP Agent	SNMP v1/v2c/v3, RMON Group 1,2,3 and 9
Switching Fabric Capacity	8Gbps	Software Upgrade	TFTP/HTTP
Transmission Method	Store and Forward Switching	Ethernet OAM	IEEE 802.3ah, IEEE 802.1ag, ITU-T Y.1731
Standard	IEEE 802.3u, IEEE 802.3z, IEEE 802.3ab, IEEE 802.3x, IEEE 802.1p, IEEE 802.1Q, IEEE 802.1ad, IEEE 802.1D, IEEE 802.1w, IEEE 802.1s, IEEE 802.1x, IEEE 802.3ad, IEEE802.3ah, IEEE802.1ag, ITU-T Y.1731, ITU-T G.8031, ITU-T G.8032	LED Display	Power, System, Console, Link, Speed/Act
Packet Buffer	4M bits	Power Input	100V ~ 240VAC, -18 ~ -72VDC
MAC Table Size	8K	Power Consumption	< 12W
Max. Packet Size	9.6K Bytes	Operating Temperature	0 ~ 50°C
VLAN Feature	IEEE 802.1Q tagged VLAN(Max. 4K VLAN groups), port based VLAN, MAC based VLAN, protocol based VLAN, private VLAN, IEEE 802.1ad Q-in-Q, VLAN translation, GVRP	Humidity	5% ~ 90% (non-condensing)
QoS Feature	IEEE 802.1p 8 priority queues per port, CoS based on switch port; VLAN ID; DSCP; TCP/UDP port, IEEE 802.1p priority tag remarking, DSCP remarking, Port based ingress/egress rate limit, 3 colors marker-CIR/EIR/Burst bandwidth control	Dimensions	Card: 201 x 135 x 35 mm (D x W x H)
L2 switching protection	STP, RSTP, MSTP, ITU-T G.8031/G.8032 Ethernet ring protection	Regulatory	FCC, CE
Trunking	IEEE 802.3ad LACP(Max. 2 trunking group, Max. 4 ports per trunking group)		
Security	IEEE 802.1x port based access control, MAC based access control authentication, RADIUS authentication, limited MAC address learning, IP/MAC binding, ACL rule based filtering, TACACS+, IP source guard, DHCP snooping/relay option 82, ARP inspection		
IP Multicasting	IGMP throttling, IGMP filtering, IGMP fast leave, IGMP snooping v1/v2/v3, MVR, MLD snooping v1/v2		
Storm Control	Unicast/Broadcast/Multicast storm suppression		

Ethernet Demarcation Device (EDD)

Application

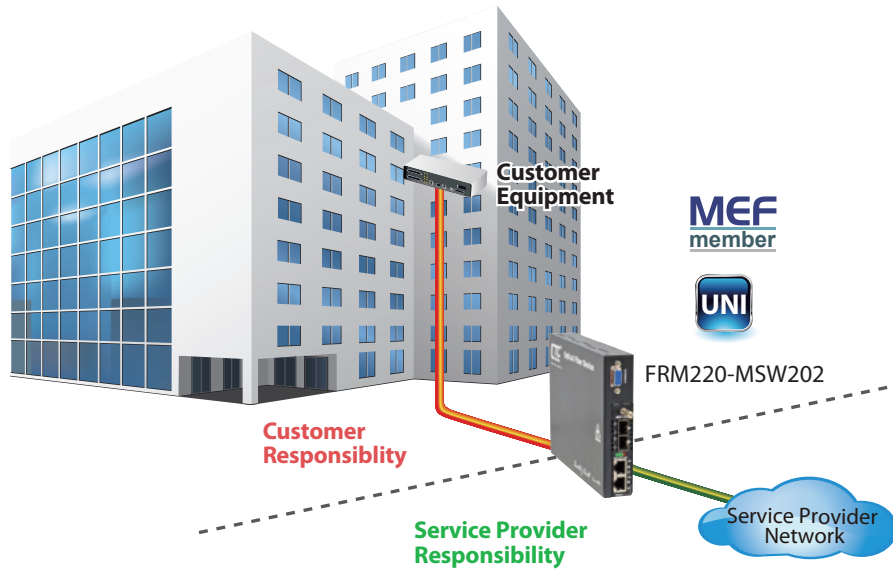

Ordering Information

Model Name	Description
FRM220-MSW202	2x 10/100/1000Base-T + 2x 100/1000Base-X OAM Managed Switch

Note: To Support Console Interface managed, this card must be placed in CH01M chassis.



FRM220-MX210

10/100/1000Base-T + 2x 100/1000/2500Base-X and 100/1000Base-X L2+ Gigabit Carrier Ethernet Switch (EDD)

FRM220-MX210 is a carrier class Ethernet Demarcation Device (EDD) with 10/100/1000Base-T Ethernet ports + 2x 100/1000/2500Base-X and 100/1000Base-X SFP fiber ports which enables EPL (Ethernet Private Line) & EVPL (Ethernet Virtual Private Line) services with advanced carrier Ethernet features per the Metro Ethernet Forum (MEF 9 and 14). By supporting link and service Ethernet OAM schemes, the FRM220-MX210 also provides extensive fault detection and diagnostic capabilities to ensure that actual network use complies with pre-agreed service level agreements (SLAs).

Feature

- Complies with MEF CE1.0
- Supports 8K MAC
- Spanning Tree 802.1D, 802.1s, 802.1w
- Supports 802.1Q / 256 active VLANs
- Double VLAN Tagging (C-tag/S-tag) (IEEE 802.1ad) support for ISP application
- Various QoS capability (MAC/port/802.1p/Diffserv)
- Port-based rate limiting
- DHCP Snooping
- IGMP Snooping
- IPv6 support
- IEEE 802.3x and IEEE 802.1x support
- Jumbo frame for up to 9.6K
- Extensive Ethernet OAM support
- IEEE 802.3ah, IEEE 802.1ag, ITU-T Y.1731
- SNMP v1/v2c/v3, Telnet, Web GUI
- IEEE 1588 V2 aware (Optional)

Specifications

Optical Interface	Port1/Port2	100Base-FX, 1000Base-X or 2500Base-X SFP-LC	Qos Feature	IEEE802.1p priority tag remarking, DSCP remarking, Port based ingress/egress rate limit
	Port3	1000Base-FX or 1000Base-X SFP-LC		
Electrical Interface	Port4	10/100/1000Base-T RJ45 MDI/MDIX auto crossover IEEE802.3x flow control	L2 switching Protection	STP, RSTP, MSTP, ITU-T G8031/G.8032
		(Supports manual 10,100,1000Base-T, Full, Half duplex, or n-way (Auto-Negotiation) each channel)	Trunking	IEEE 802.3ad LACP
Standards		IEEE 802.3 10Base-T, IEEE 802.3u, 100Base-TX, 100Base-FX, IEEE 802.3z 1000Base-X, IEEE 802.3ab, 1000Base-T	Power	12VDC
LEDs		PWR, Link (Port1, Port2, Port3) Port4: Link/Speed	Power Consumption	< 12W
VLAN Feature		IEEE 802.1Q tagged VLAN, port based VLAN, MAC based VLAN, protocol based VLAN, private VLAN, IEEE 802.1ad Q-in-Q	Dimensions	Card: 155 x 20.8 x 88mm (D x W x H)
Qos Feature		IEEE 802.1p 8 priority queues per port, Cos based on switch port; VLAN ID; TCP/UDP port.	Weight	120g
			Temperature	0 ~ 50°C (Operating), -10 ~ 70°C (Storage)
			Humidity	20 ~ 80% non-condensing (Operating); 10 ~ 90% (Storage)
			Certification	CE, FCC
			MTBF	65,000 hrs

Application

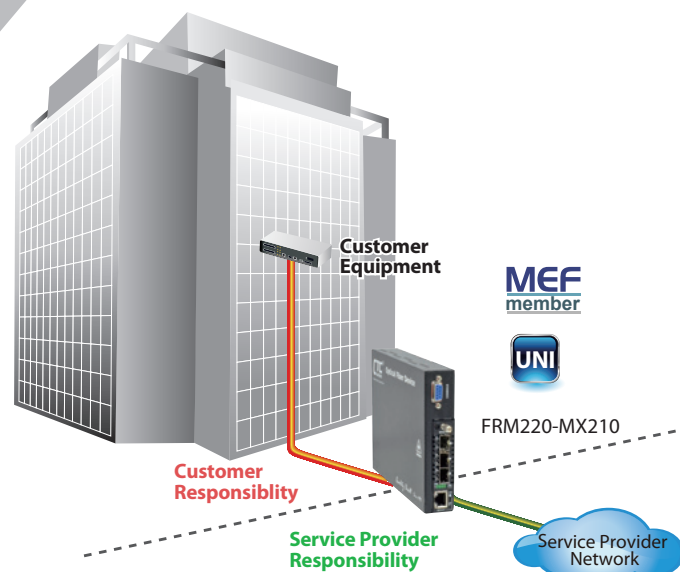

Ordering Information

Model Name	Description
FRM220-MX210	10/100/1000Base-T + 2x 100/1000/2500Base-X + 100/1000Base-X OAM Managed Switch

Note: To Support Console Interface managed, this card must be placed in CH01M chassis.



FRM220A-1002ES

2x 10/100/1000Base-T +
2x 100/1000Base-X SFP GbE Switch

The FRM220A-1002ES is a dual copper and dual fiber Gigabit Ethernet switch designed to make conversion between 10/100/1000Base-T and 100/1000Base-SX/LX with SFP connector. With SNMP and Web-based management in the FRM220 or FRM220A chassis the network administrator can monitor, configure and control the activity of each FRM220A-1002ES switch card locally via the chassis management. Based on a powerful L2 switch architecture, this converter supports bandwidth control, duplex and speed configuration, VLAN tagging, Q-in-Q, QoS, jumbo frames as well as auto laser shutdown, and link fault pass through. When placed stand-alone, this card may only be managed via local serial console when placed in a CH01M single slot type chassis.

Feature

- 2-Port 10/100/1000Base-T and 2-Port 100/1000Base-X Switch
- Auto-Cross over for MDI/MDIX in TP port
- Auto-Negotiation or manual mode in TP port
- Supports flow control Enable or Disable
- Supports Jumbo Frame 10K Bytes
- Supports 16 Tag VLAN Group
- Supports Double VLAN tag (Q-in-Q)
- Supports Bandwidth control
- Supports Loop Back Test
- Supports Link Fault Pass-Through (LFPT) Function
- Supports Auto Laser Shutdown (ALS) Function
- Supports local management on FRM220A rack management.
- Console management on stand-alone.
- Supports D/D function for SFP fiber transceiver
- Provide Product information for management
- Supports the local management (Monitor or Configure status) by the SNMP manager.
- Supports FRM220A for Ethernet Aggregation

Specifications

Optical Interface	Connector	SFP LC	Certification	FCC Part 15 Class A, CE Mark		
	Data rate	125Mbps, 1250Mbps		Electrical Interface	Connector	RJ45
	Duplex mode	Full duplex			Data rate	10Mbps, 100Mbps, 1000Mbps
	Fiber	MM 50/125µm, 62.5/125µm SM 9/125µm		Cable	10Base-T Cat.3, 4, 5, UTP 100Base-TX Cat.5, 5e or higher 1000Base-X Cat.5e or higher	
	Distance	MM 2km, SM 15/30/50/80/120km WDM 20/40/60/80km		Power	12VDC	
Wavelength	MM 1310nm, SM 1310,1550nm WDM 1310Tx/1550Rx (type A) 1550Tx/1310Rx (type B)	Power Consumption	< 12W			
Standards	IEEE 802.3, IEEE 802.3u, 802.3z, 802.3ab, 802.1Q, 802.3X, 802.1ad		Dimensions	Card: 155 x 20.8 x 88mm (DxWxH)		
Indications	PWR, LNK1, LNK2, TEST, LAN Link, LAN SPEED		Weight	130g		
			Temperature	0~50°C (Operating), -10~70°C (Storage)		
			Humidity	0 ~ 95% non-condensing		

Application

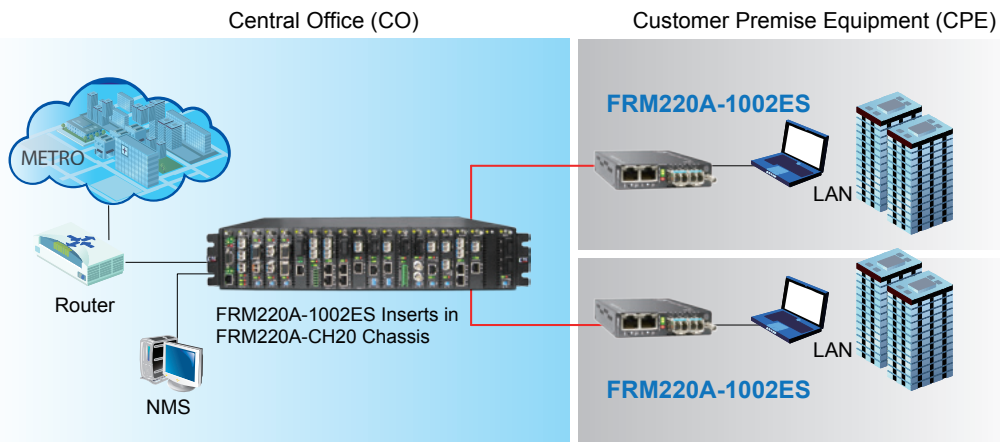

Ordering Information

Model Name	Description
FRM220A-1002ES	2-Port 10/100/1000Base-T and 2-Port 100/1000Base-SX/LX SFP GE Manage Switch (Optional SFP)

Note: Note: This card must use CH01M with serial console, to configure standalone settings.



FRM220A-1000EAS/X

2x 10/100/1000Base-T and
2x 100/1000Base-X SFP OAM/IP GbE
Managed Switch

The FRM220A-1000EAS/X is an IEEE 802.3ah OAM compliant dual copper and dual fiber Gigabit Ethernet switch solution designed to make conversion between 10/100/1000Base-T(X) and 100/1000Base-X with SFP. With embedded SNMP and Web-based management, the network administrator can monitor, configure and control the activity of each IEEE 802.3ah series card and remotely connected OAM compliant converter. Based on a powerful L2 switch architecture, this converter supports bandwidth control, duplex and speed configuration, VLAN tagging, Q-in-Q, QoS, Spanning tree, jumbo frames as well as auto laser shutdown, link fault pass through, OAM loop back and dying gasp. This card may also be controlled and monitored via an NMC in a managed chassis.

Feature

- 2-port 10/100/1000Base-T and 2-port 100/1000Base-X SFP
- Supports local / remote IEEE 802.3ah OAM / IP In-band management
- Standalone IP Based, Web GUI, Telnet, SNMP management
- Auto-Negotiation or forced mode
- Auto MDI/MDIX
- Supports IEEE 802.1Q Tagged and Port based VLAN
- Supports IEEE 802.1ad Q in Q double tagging
- Forward 10K bytes Jumbo packets (max.)
- Supports Flow control (Pause)
- Supports OAM remote loopback to assist in diagnosing network problems
- RADIUS Client
- Supports bandwidth control
- Supports remote CPE power fail detect (dying gasp)
- Supports Far End Fault Indication (FEFI)
- Supports Link Fault Pass-Through (LFPT)
- Supports RMON counter
- D/D function for supported SFP fiber transceiver
- Auto Laser Shutdown (ALS)
- Online local / remote f/w upgrade
- Fiber Redundant mode
- Spanning Tree Protocol
- Port Trunking
- Default port and 802.1p tag priority QoS
- Fixed or weighted priority QoS

Specifications

Optical Interface	Connector	SFP LC	Electrical Interface	Connector	RJ45
	Data rate	125/1250Mbps		Data rate	10Mbps, 100Mbps, 1000Mbps
	Duplex mode	Full duplex		Duplex mode	Half / Full duplex
	Fiber	MM 50/125µm, 62.5/125µm. SM 9/125µm		Cable	10Base-T Cat.3, 4, 5, UTP 100Base-TX Cat.5, 5e or higher 1000Base-T Cat.5, 5e or higher
	Distance	MM 550m, 2km, SM 15/30/50/80/120km WDM 20/40/60km		Standards	IEEE 802.3, IEEE 802.3u, IEEE802.1Q, IEEE 802.3ah
Wavelength	MM 1310nm, SM 1310,1550nm WDM 1310Tx/1550Rx (type A) 1550Tx/1310Rx (type B)	Indications	LED (Power, FX-Link, Test, TX-Link, TX-SPD)		
Power Consumption	< 12W	Power Input	12VDC		
Dimensions	Card: 155 x 20.8 x 88mm (DxWxH)	Temperature	0 ~ 50°C (Operating), -10 ~ 70°C (Storage)		
Weight	130g	Humidity	10 ~ 90% non-condensing		
		Certification	CE, FCC		
		MTBF	65,000 hrs		

Ordering Information

Model Name	Description
FRM220A-1000EAS/X	2-Port 10/100/1000Base-T and 2-Port 100/1000Base-X with OAM/IP management, (optional SFP)

Note: This card may use CH01M to provide console for initial TCP/IP settings, or use CH01 with default IP.

OAM/IP GbE Management Switch

FRM220A-1000EAS/X Application

In the Centrally managed application, the main chassis, all of its cards and all fiber connected remote CPE units can be provisioned and monitored from a single management point

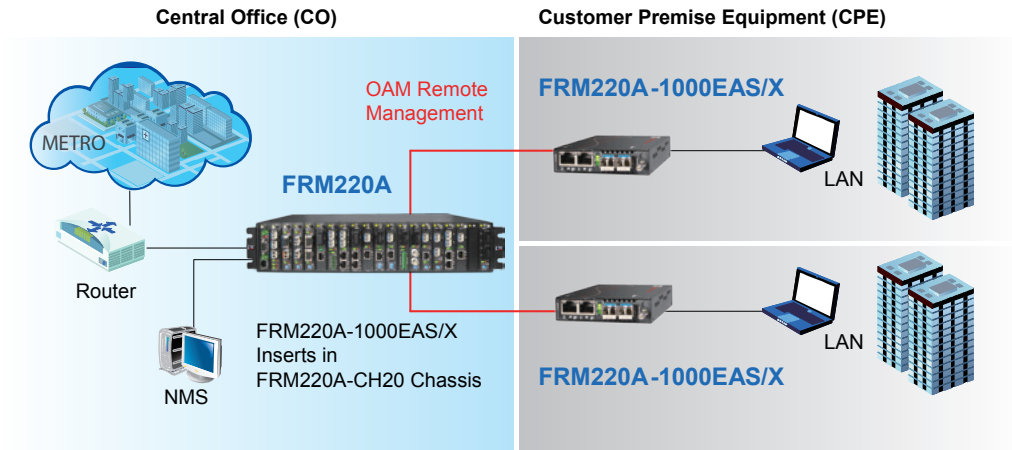

Fiber Redundant / Trunking Application

Utilizing a special trunking function, the 1000EAS/X can be deployed in stand-alone, point-to-point applications and provide 1+1 redundant fiber protection

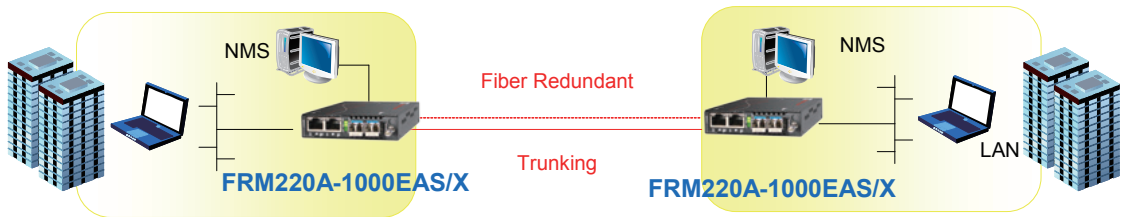

Fiber Ring Application

In the ring or mesh topology, Spanning Tree Protocol enables a highly resilient network based on multiple 1000EAS/X units

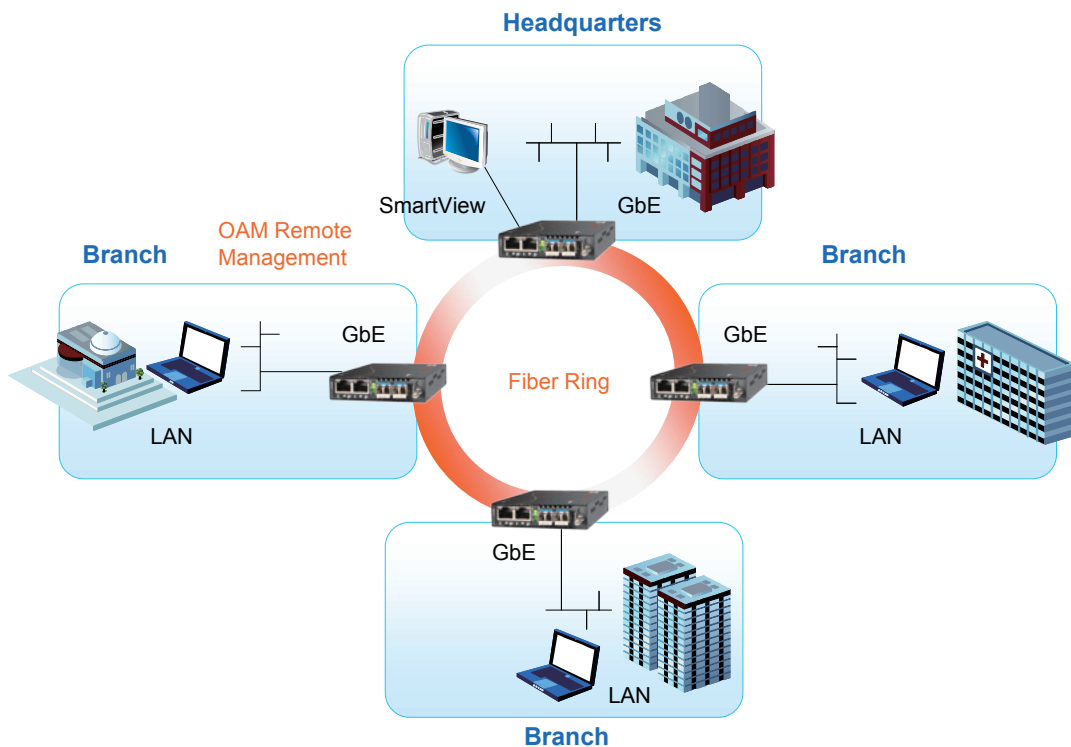



FRM220-10/100

10/100Base-TX to 100Base-FX Unmanaged Media Converter

FRM220-10/100 is a Fast Ethernet 10/100Base-TX to 100Base-FX non-managed stand-alone media converter, which gives the options to choose from the most popular fiber cabling connectors, ST, SC or FC. Both multi-mode and single mode converter models are available as well as BiDi which allows bi-directional transmissions using only a single fiber core. When auto-negotiation is selected, these units will automatically tailor themselves to convert both half-duplex and full-duplex signals, according to IEEE802.3u standards. LED indicators signal the power status of the converter, UTP port speed, Link, and duplex status, FX port Link and duplex status. These non-managed stand-alone converters may also be concentrated into either the FRM220-CH20 or FRM220-CH08 managed chassis.

Feature

- 10/100Base-TX to 100Base-FX Converter
- Auto-Negotiation or forced mode
- Auto MDI/MDIX
- Forward 1600 bytes (Max.) packets
- Supports Q in Q double tagged frame transparent
- Supports IEEE 802.1q Tag VLAN pass thru
- Support flow control (Pause)
- Supports Link Fault Pass through (LFP)
- Forward 9K jumbo packets in converter mode

Specifications

Optical Interface	Connector	1x9 (SC, ST, FC)
	Data rate	100Mbps
	Duplex mode	Full duplex
	Fiber	MM 50/125µm, 62.5/125µm SM 9/125µm
	Distance	MM 2km, SM 15/30/50/80/120km WDM 20/40/60/80km
	Wavelength	MM 1310nm, SM 1310,1550nm WDM 1310Tx/1550Rx (type A) 1550Tx/1310Rx (type B)
Standards	IEEE 802.3, IEEE 802.3u	
Indications	LED (Power, FX Link, TX SPD, TX Link, TX Duplex, FEF)	
Certification	CE, FCC, RoHS	

Electrical Interface	Connector	RJ-45
	Data rate	10Mbps, 100Mbps
	Cable	10Base-T Cat.3, 4, 5, UTP, 100Base-TX Cat.5, 5e or higher
Power	12VDC	
Power Consumption	< 4W	
Dimensions	Card: 155 x 20.8 x 88mm (D x W x H)	
Weight	120g	
Temperature	0 ~ 60°C (Operating), -10 ~ 70°C (Storage)	
Humidity	10 ~ 90% non-condensing	
MTBF	65,000 hrs	

Application

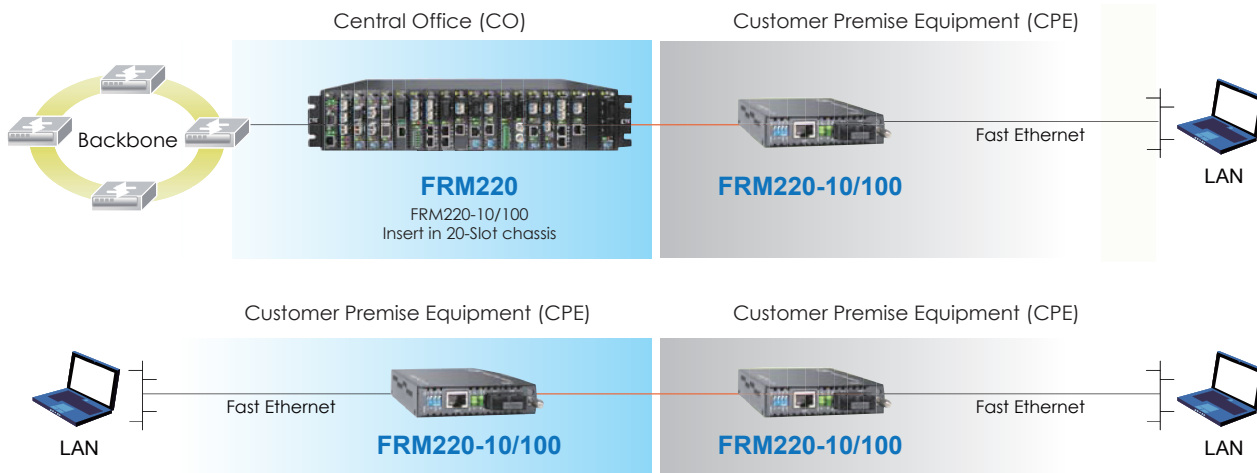

Ordering Information

Model Name	Description
FRM220-10/100	10/100Base-TX to 100Base-FX unmanaged media converter
Connector Type	Connectivity Distance
SC,ST,FC	002: 2km 015: 15km 030: 30km 050: 50km 080: 80km 120: 120km
	20A: WDM 20km A type 20B: WDM 20km B type 40A: WDM 40km A type 40B: WDM 40km B type
	60A: WDM 60km A type 60B: WDM 60km B type 80A: WDM 80km A type 80B: WDM 80km B type

Connector Type Connectivity Distance
FRM220 - 10/100 -
 Example: FRM220 - 10/100 - SC002



FRM220-1000DS

1000Base-X to 1000Base-X Media Converter

The FRM220-1000DS is a fiber to fiber optical media converter and repeater that allows data rates up to 1Gbps. FRM220-1000DS supports 2R regeneration, which consists of re-amplification and reshaping. This converter is compatible with fiber interfaces such as 100Mbps Fast Ethernet and 1000Mbps Gigabit Ethernet, STM-1, Fiber Channel 1 and OC3, The FRM220-1000DS works as an FRM220 slide-in card, while the FRM220-1000DS plus FRM220-CH01 work as a stand-alone fiber converter. When the FRM220-1000DS card is placed in the FRM220-CH20 rack with SNMP management, the management can view the converter card's status, type, fiber link status and SFP DOM.

Feature

- Transparent FE or GbE fiber media converter / repeater
- Data rate up to 1G
- Network management via terminal or SNMP in FRM220 chassis
- Extend transmission from 2km to 120km over fiber
- Perform optical repeater function (Re-amplification & Reshaping)
- Digital diagnostic monitoring of SFP modules

Specifications

Optical Interface	Connector	SFP LC x 2
	Data rate	Up to 1G
	Duplex mode	Full duplex
	Fiber	MM 50/125µm, 62.5/125µm. SM 9/125µm
	Distance	MM 550m, 2km, SM 15/30/50/80/120km WDM 20/40/60km
	Wavelength	MM 1310nm, SM 1310,1550nm WDM 1310Tx/1550Rx (type A) 1550Tx/1310Rx (type B)
Indications	LED (Power, FX-Link1, FX-Link2)	
Power Input	12VDC	

Power Consumption	< 6W
Dimensions	Card: 155 x 20.8 x 88 mm (D x W x H)
Weight	130g
Temperature	0 ~ 50°C (Operating), -10 ~ 70°C (Storage)
Humidity	10 ~ 90% non-condensing
Certification	CE, FCC
MTBF	65,000 hrs

Application

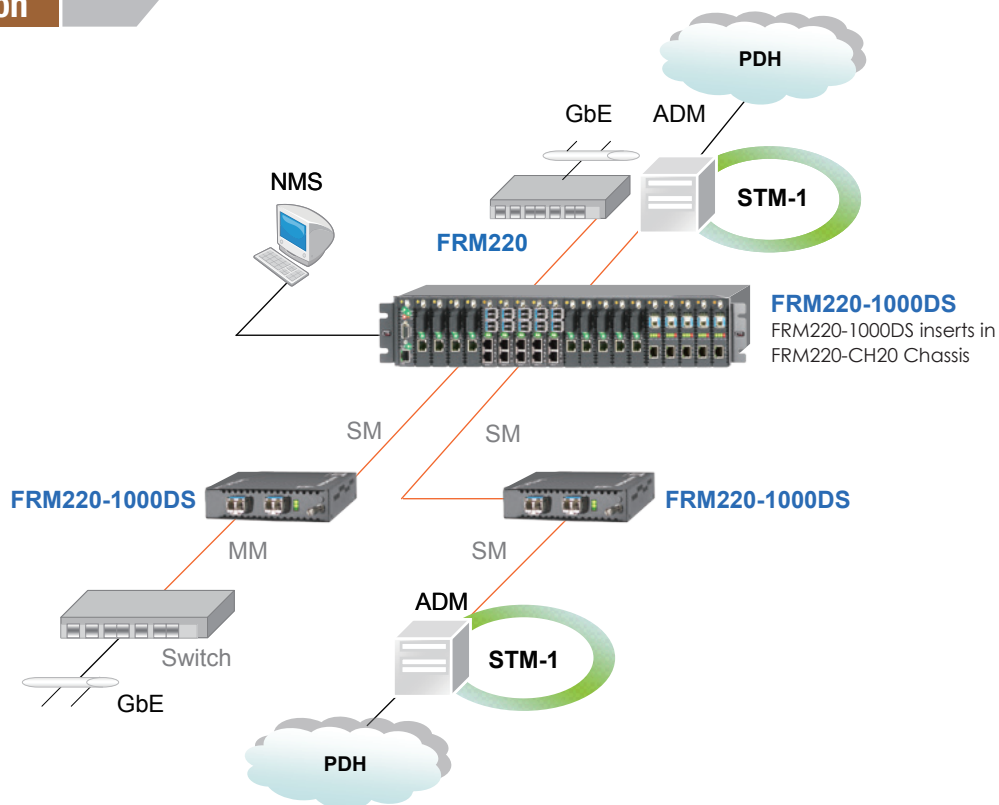

Ordering Information

Model Name	Description
FRM220-1000DS	1000Base-X SFP to 1000Base-X SFP Media Converter (Optional SFP)

Accessories**Multi-Mode 1.25Gbps SFP**

SFM-7000-S85	1.25G SX, MM, 550m, 850nm, 8.5dB, 3.3V, LC
SFM-7000-S85-DD	1.25G SX, MM, 550m, 850nm, 8.5dB, 3.3V, LC, DD
SFM-7000-L31	1.25G LX, MM, 2km, 1310nm, 10dB, 3.3V, LC
SFM-7000-L31-DD	1.25G LX, MM, 2km, 1310nm, 10dB, 3.3V, LC, DD

Single-Mode 1.25Gbps SFP

SFS-7020-L31	1.25G LX, SM, 20km, 1310nm, 15dB, 3.3V, LC
SFS-7020-L31-DD	1.25G LX, SM, 20km, 1310nm, 15dB, 3.3V, LC, DD
SFS-7040-L31	1.25G LX, SM, 40km, 1310nm, 20dB, 3.3V, LC, DFB LD
SFS-7040-L31-DD	1.25G LX, SM, 40km, 1310nm, 20dB, 3.3V, LC, DFB LD, DD

Single Fiber 1.25Gbps SFP

SFS-7020-WA	1.25G WDM, 20km, Tx1310nm / Rx1550nm (A type), 3.3V, LC
SFS-7020-WA-DD	1.25G WDM, 20km, Tx1310nm / Rx1550nm (A type), 3.3V, LC, DD
SFS-7020-WB	1.25G WDM, 20km, Tx1550nm / Rx1310nm (B type), 3.3V, LC
SFS-7020-WB-DD	1.25G WDM, 20km, Tx1550nm / Rx1310nm (B type), 3.3V, LC, DD
SFS-7040-WA	1.25G WDM, 40km, Tx1310nm / Rx1550nm (A type), 3.3V, LC
SFS-7040-WA-DD	1.25G WDM, 40km, Tx1310nm / Rx1550nm (A type), 3.3V, LC, DD
SFS-7040-WB	1.25G WDM, 40km, Tx1550nm / Rx1310nm (B type), 3.3V, LC
SFS-7040-WB-DD	1.25G WDM, 40km, Tx1550nm / Rx1310nm (B type), 3.3V, LC, DD



FRM220-1000TS

1000Base-T to 1000Base-X SFP Media Converter

The FRM220-1000TS is a transparent Gigabit Ethernet 1000Base-T to 1000Base-SX/LX SFP converter with very low latency. They are managed (when installed in FRM220 with NMC) or non-managed stand-alone media converters, which give you the options to choose from a wide range of industry standard SFP modules with LC connectors. SFPs in multi-mode and single mode types are available as well as BiDi which allows bi-directional transmissions using only a single fiber cable. Because they are completely transparent to Ethernet packets, they are able to support any size frames, including undersized or jumbo packets (>9K bytes). LED indicators signal the power status of the converter, UTP port speed, Link, and duplex status, FX port Link and duplex status.

Feature

- 1000Base-T to 1000Base-SX/LX
- Network management via terminal or SNMP in FRM220 chassis
- Auto-negotiation or force mode
- Auto MDI/MDIX
- Forward > 9K bytes packets
- Supports Link Fault Pass Through (LFP) function
- Auto Laser Shutdown (ALS)
- Protocol Transparent

Specifications

Optical Interface	Connector	SFP LC
	Data rate	1000Mbps
	Duplex mode	Full duplex
	Fiber	MM 50/125µm, 62.5/125µm SM 9/125µm
	Distance	MM 550m, 2km, SM15/30/50/80/120km WDM 20/40/60km
Wavelength	MM	1310nm, SM 1310,1550nm
	WDM	1310Tx/1550Rx (type A)
		1550Tx/1310Rx (type B)
Electrical Interface	Connector	RJ45
	Data rate	1000Mbps
	Duplex mode	Full duplex
	Cable	10Base-T Cat.3, 4, 5, UTP

Standard	IEEE 802.3ab
Indications	LED (Power, FX-Link, FX Duplex, TX-SPD, TX-Duplex, TX-Link)
Power Input	Card : 12VDC Standalone : AC, DC options
Power Consumption	< 12W
Dimensions	Card: 155 x 20.8 x 88mm (D x W x H)
Weight	120g
Temperature	0 ~ 50°C (Operating), -10 ~ 70°C (Storage)
Humidity	10 ~ 90% non-condensing
Certification	CE, FCC, LVD
MTBF	65,000 hrs (25°C)

Application

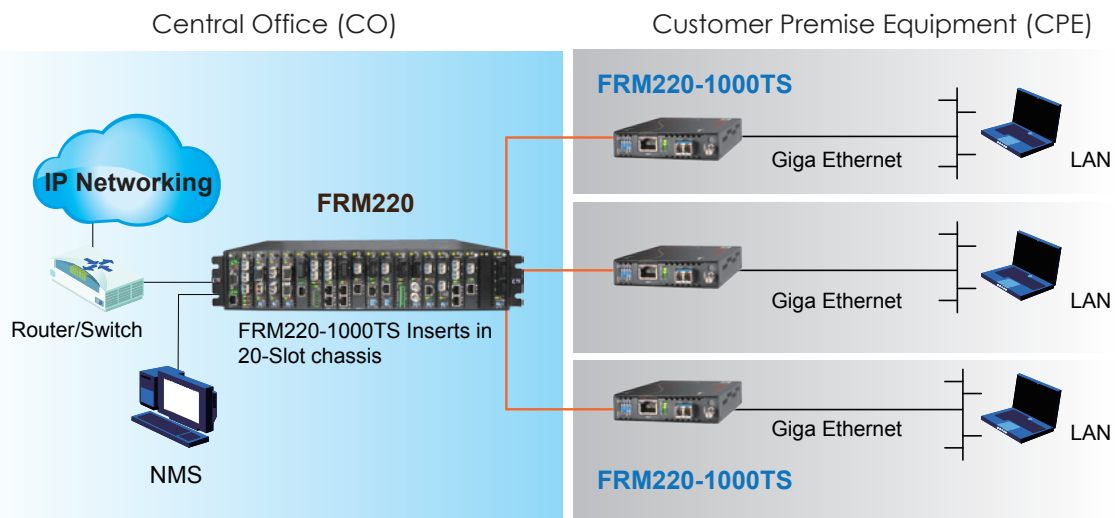

Ordering Information

Model Name	Description
FRM220-1000TS	1000Base-T to 1000Base-X SFP media converter (Optional SFP)



FRM220-1000M

Web Smart OAM Managed 10/100/1000Base-T to 1000Base-X GbE Media Converter

The FRM220-1000M is an IEEE802.3ah OAM compliant copper to fiber Gigabit Ethernet solution designed to make conversion between 10/100/1000Base-T and 100M/1000Base-X with SC, FC or ST connectors. With SNMP and Web-based management in the FRM220, the network administrator can monitor, configure and control the activity of each 802.3ah series card and remotely connected OAM compliant converter. Converter settings include band-width control, duplex, and speed configuration, VLAN tagging and limited Q-in-Q support. When used as stand-alone converters, the 1000M can be managed by a friendly WebSmart user interface via any web browser.

Feature

- 10/100/1000Base-T to 1000Base-X Converter
- Auto-Cross over for MDI/MDIX in TP port
- Auto-Negotiation or manual mode in TP port
- Supports flow control Enable or Disable
- Supports Jumbo Frame 9K Bite
- Ingress / Egress bandwidth control
- Supports IEEE 802.3ah OAM in-band management
- Firmware upgrade via Web
- Management Password Security
- Dying gasp (remote power failure detection)
- Supports Link Fault Pass-Through (LFPT) Function
- Supports Auto Laser Shutdown (ALS) Function
- Allow IP settings Web or Console management on stand-alone.
- Provide Product information for management
- Online local/remote f/w upgrade
- Supports 16 Tag VLAN Group
- RMON counters (for standalone unit only)

Specifications

Optical Interface	Connector	1x9 (SC)
	Data rate	125/1250Mbps
	Duplex mode	Full duplex
	Fiber	MM 50/125µm, 62.5/125µm SM 9/125µm
	Distance	MM 2km, SM 15/30/50/80/120km WDM 20/40/60/80km
	Wavelength	MM 1310nm, SM 1310,1550nm WDM 1310Tx/1550Rx (type A) 1550Tx/1310Rx (type B)
Electrical Interface	Connector	RJ45
	Data rate	10Mbps, 100Mbps, 1000Mbps
	Duplex mode	Half / Full duplex
	Cable	10Base-T Cat.3, 4, 5, UTP, 100Base-TX Cat.5, 5e or higher

Standards	IEEE 802.3, IEEE 802.3u IEEE 802.3ab, 802.3z, 802.3ah, 802.1Q
Indications	LED (Power, FX-Link, LAN Speed, LAN Link)
Power Input	12VDC
Power Consumption	< 6W
Dimensions	Card: 155 x 20.8 x 88mm (D x W x H)
Weight	120g
Temperature	0 ~ 50°C (Operating), -10 ~ 70°C (Storage)
Humidity	10 ~ 90% non-condensing
Certification	CE, FCC
MTBF	65,000 hrs

Application

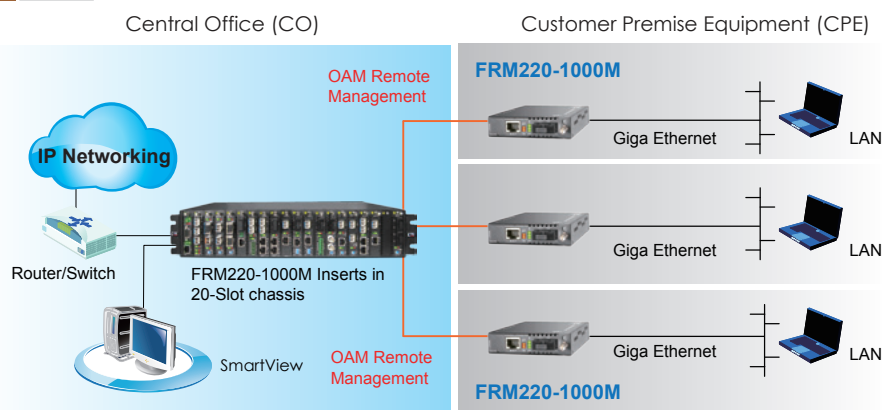

Ordering Information

Model Name	Description
FRM220-1000M	10/100/1000Base-T to 1000Base-X, Web Smart OAM managed media converter
Connector Type	Connectivity Distance
SC	002: 2km 015: 15km 030: 30km 050: 50km 20A: WDM 20km A type 20B: WDM 20km B type 40A: WDM 40km A type 40B: WDM 40km B type

Note: This card may use CH01M to provide console for initial TCP/IP settings, or use CH01 with default IP.



FRM220-1000MS

Web Smart OAM Managed 10/100/1000Base-T to 100/1000Base-X SFP GbE Media Converter

The FRM220-1000MS is an IEEE802.3ah OAM compliant copper to fiber Gigabit Ethernet solution designed to make conversion between 10/100/1000Base-T and 100/1000Base-X with SFP modules. With SNMP and Web-based management in the FRM220, the network administrator can monitor, configure and control the activity of each 802.3ah series card and remotely connected OAM compliant converter. Converter settings include bandwidth control, duplex, and speed configuration, VLAN tagging, limited Q-in-Q support and SFP DDMI. When used as stand-alone converters, the 1000M can be managed by a friendly WebSmart user interface via any web browser.

Feature

- 1-Port 10/100/1000Base-T to 100/1000Base-X Converter
- Auto-Cross over for MDI/MDIX in TP port
- Auto-Negotiation or manual mode in TP port
- Supports flow control Enable or Disable
- Supports Jumbo Frame 9K Packet
- Ingress / Egress bandwidth control
- Supports 802.3ah-OAM in-band management
- Firmware upgrade via Web (for standalone unit only)
- Management Password Setting (for standalone unit only)
- Dying gasp (remote power failure detection on stand-alone)
- Supports Link Fault Pass-Through (LFPT) Function
- Supports Auto Laser Shutdown (ALS) Function
- Allow IP settings web or console management
- Supports D/D function for SFP fiber transceiver
- Supports 16 Tag VLAN Group
- RMON counters (for standalone unit only)

Specifications

Optical Interface	Connector	SFP LC	Standards	IEEE 802.3, 802.3u, 802.3ab, 802.3z, 802.3ah, 802.1Q				
	Data rate	125/1250Mbps		Indications	LED (Power, FX-Link, LAN Speed, LAN Link)			
	Duplex mode	Full duplex			Power Input	12VDC		
	Fiber	MM 50/125µm, 62.5/125µm. SM 9/125µm				Power Consumption	< 6W	
	Distance	MM 2km, SM 15/30/50/80/120km, WDM 20/40/60/80km					Dimensions	Card: 155 x 20.8 x 88mm (D x W x H)
	Wavelength	MM 1310nm, SM 1310,1550nm WDM 1310Tx/1550Rx (type A) 1550Tx/1310Rx (type B)						Weight
Electrical Interface	Connector	RJ45	Temperature					
	Data rate	10Mbps, 100Mbps, 1000Mbps		Humidity				
	Duplex mode	Half / Full duplex			Certification			
	Cable	10Base-T Cat.3, 4, 5, UTP 100Base-TX Cat.5, 5e or higher				MTBF		

Application

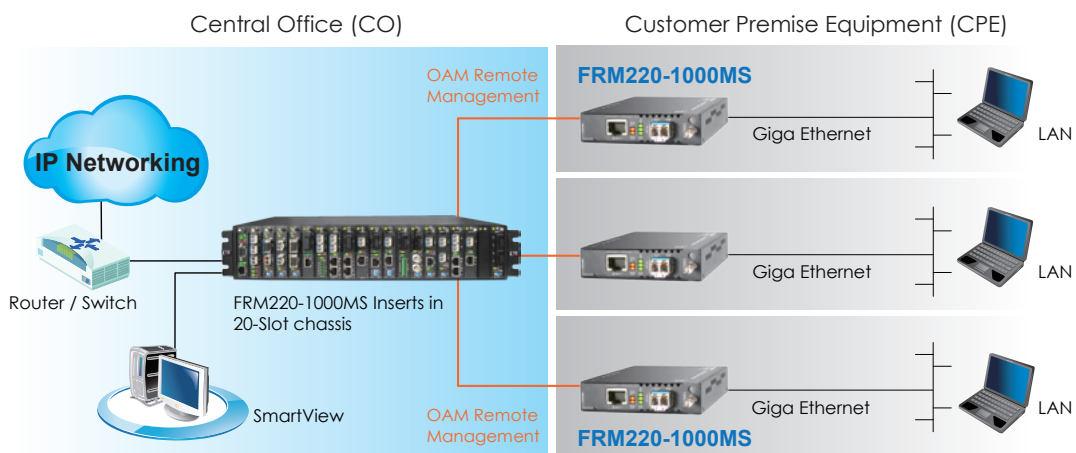

Ordering Information

Model Name	Description
FRM220-1000MS	10/100/1000Base-T to 100/1000Base-X SFP Web smart OAM managed media converter. (Optional SFP)

Note: This card may use CH01M to provide console for initial TCP/IP settings, or use CH01 with default IP.



FRM220-1000EAS/X-1

OAM/IP Managed 10/100/1000Base-T to 100/1000Base-X SFP GbE Media Converter

The FRM220-1000EAS/X-1 is an IEEE802.3ah OAM compliant copper to fiber Gigabit Ethernet solution designed to make conversion between 10/100/1000Base-T and 100/1000Base-X with SFP. With stand-alone SNMP and Web-based management, the network administrator can monitor, configure and control the activity of each IEEE802.3ah series card and remotely connected OAM compliant converter. By offering IEEE802.3ah OAM in-band management, this converter can also be completely controlled and monitored from a centrally located managed rack. Based on a powerful L2 switch architecture, this converter supports bandwidth control, duplex and speed configuration, VLAN tagging, Q-in-Q, QoS, Spanning tree as well as auto laser shutdown, link fault pass through, OAM loop back and dying gasp.

Feature

- 10/100/1000Base-T to 100/1000Base-X SFP
- Supports local / remote IEEE802.3ah OAM/ IP In-band management
- Stand-alone IP Based, Web GUI, Telnet, SNMP management
- Auto-Negotiation or forced mode
- Auto MDI/MDIX
- Supports IEEE 802.1Q Tagging
- Supports Q in Q double tagging
- Forward 10K bytes Jumbo packets (max.)
- Supports Flow control (Pause)
- Supports OAM remote loopback to assist in diagnosing network problems
- Supports remote IP ping function for diagnostic purpose
- Supports bandwidth control
- Supports remote CPE power fail detect (dying gasp)
- Supports Far End Fault Indication (FEFI)
- Supports Link Fault Pass-Through (LFPT)
- Supports RMON counter
- D/D function for supported SFP fiber transceiver
- Auto Laser Shutdown (ALS)
- Online local / remote f/w upgrade
- Default port and IEEE802.1Q Tagging priority QoS

Specifications

Optical Interface	Connector	SFP LC
	Data rate	100/1000Mbps
	Duplex mode	Full duplex
	Fiber	MM 50/125µm, 62.5/125µm. SM 9/125µm
	Distance	MM 550m, 2km, SM 15/30/50/80/120km WDM 20/40/60km
	Wavelength	MM 1310nm, SM 1310, 1550nm WDM 1310Tx/1550Rx (type A) 1550Tx/1310Rx (type B)
Power Consumption	< 8W	
Dimensions	Card: 155 x 20.8 x 88mm (D x W x H)	
Weight	120g	

Electrical Interface	Connector	RJ45
	Data rate	10Mbps, 100Mbps, 1000Mbps
	Duplex mode	Half / Full duplex
	Cable	10Base-T Cat.3, 4, 5, UTP 100Base-TX Cat.5, 5e or higher 1000Base-T Cat.5, 5e or higher
Standards	IEEE 802.3, IEEE 802.3u, IEEE 802.1Q, IEEE 802.3ab, IEEE 802.3z	
Indications	LED : Power, FX-Link, FEF, TEST, Speed(10,100,1000), FULL	
Power Input	Card : 12VDC Standalone : AC, DC options	
Temperature	0 ~ 50°C (Operating), -10 ~ 70°C (Storage)	
Humidity	10 ~ 90% non-condensing	
Certification	CE, FCC	
MTBF	65,000 hrs	

Application

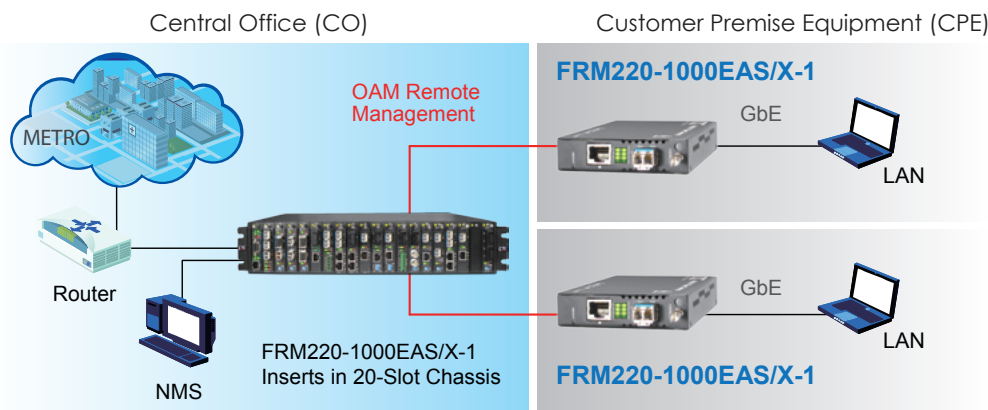

Ordering Information

Model Name	Description
FRM220-1000EAS/X-1	10/100/1000Base-T to 100/1000Base-X with OAM/IP-Based managed GbE Media Converter, (optional SFP)

Note: This card may use CH01M to provide console for initial TCP/IP settings, or use CH01 with default IP.



FRM220-100EAS/X-1

(Order Name - **FRM220-100AS-1**)

OAM/IP Managed 10/100Base-TX to 100Base-FX FE Media Converter

The FRM220-100AS-1 is an IEEE802.3ah OAM compliant copper to fiber Fast Ethernet solution designed to make conversion between 10/100Base-TX and 100Base-FX with SFP. With stand-alone SNMP and Web-based management, the network administrator can monitor, configure and control the activity of each IEEE802.3ah series card and remotely connected OAM compliant converter. By offering IEEE802.3ah OAM in-band management, this converter can also be completely controlled and monitored from a centrally located managed rack. Based on a powerful L2 switch architecture, this converter supports bandwidth control, duplex and speed configuration, VLAN tagging, Q-in-Q, QoS, Spanning tree as well as auto laser shutdown, link fault pass through, OAM loop back and dying gasp.

Feature

- 10/100Base-TX to 100Base-FX SFP
- Supports local / remote IEEE802.3ah OAM/ IP In-band management
- Stand-alone IP Based, Web GUI, Telnet, SNMP management
- Auto-Negotiation or forced mode
- Auto MDI/MDIX
- Supports IEEE 802.1Q Tagging
- Supports Q in Q double tagging
- Max. MTU size 10K bytes
- Supports Flow control (Pause)
- Supports OAM remote loopback to assist in diagnosing network problems
- Supports bandwidth control
- Supports remote CPE power fail detect (dying gasp)
- Supports Far End Fault Indication (FEFI)
- Supports Link Fault Pass-Through (LFPT)
- Supports remote loopback
- D/D function for supported SFP fiber transceiver
- Auto Laser Shutdown (ALS)
- Online local / remote f/w upgrade
- Default port and IEEE802.1Q Tagging priority QoS
- SNMP trap and LED alarm for loss of light and loss of signal

Specifications

Optical Interface	Connector	SFP LC
	Data rate	100Mbps
	Duplex mode	Full duplex
	Fiber	MM 50/125µm, 62.5/125µm. SM 9/125µm
	Distance	MM 550m, 2km, SM15/30/50/80/120km WDM 20/40/60km
Wavelength	MM	1310nm, SM 1310, 1550nm
	WDM	1310Tx/1550Rx (type A) 1550Tx/1310Rx (type B)
Power Consumption	< 12W	
Dimensions	Card: 155 x 20.8 x 88mm (D x W x H)	
Weight	120g	
Electrical Interface	Connector	RJ45
	Data rate	10Mbps, 100Mbps
	Duplex mode	Half / Full duplex

Electrical Interface	Cable: 10Base-T	Cat.3, 4, 5, UTP
	100Base-TX	Cat.5, 5e or higher
Standards	IEEE 802.3, IEEE 802.3u, IEEE 802.1Q, ITU-T G.664	
Indications	LED : Power, FX-Link, FEF, TEST, Speed(10,100), FULL	
Power Input	Card	: 12VDC
	Standalone	: AC, DC options
Temperature	Storage conditions	
	Temperature range : -5~+45°C	
	Relative Humidity : 5~95% Rh	
	Absolute Humidity : 1~25g H2O/m ³	
	Operation conditions	
Temperature range : -5~+45°C		
Relative Humidity : 5~95% Rh		
Exist conditions for condensation and icing		
Absolute Humidity : 1~29g H2O/m ³		
Certification	CE, FCC, EN60950 LVD compliant	
MTBF	65,000 hrs	

Application

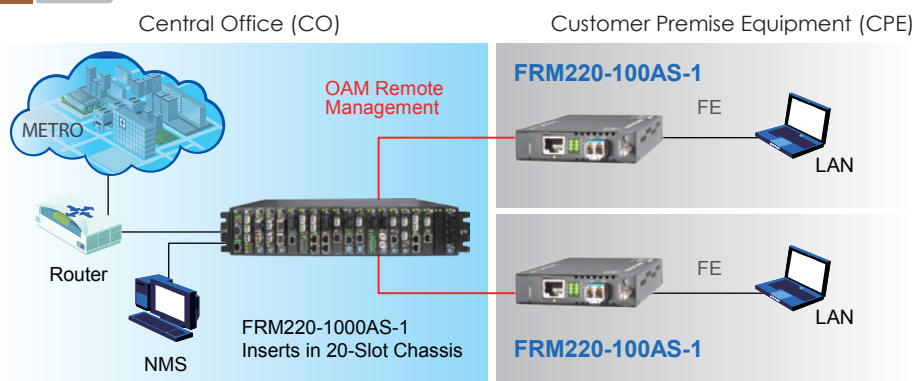

Ordering Information

Model Name	Description
FRM220-100AS-1	10/100Base-TX to 100Base-FX with OAM/IP-Based managed FE Media Converter (optional SFP)

Note: This card may use CH01M to provide console for initial TCP/IP settings, or use CH01 with default IP.



FRM220-10/100i

In-Band Management 10/100Base-TX to 100Base-FX Media Converter

The FRM220-10/100i is a 10/100Base Ethernet to 100Base-FX fiber slide-in card converter designed for central and remote applications. With advanced features like bandwidth control, this media converter is targeted for customer premises equipment in metro LAN, campus, enterprise and FTTx applications. By offering in-band management, this converter can be completely controlled and monitored from a centrally located managed rack controlling all converter settings including bandwidth control, duplex, and speed configuration. This media converter is completely transparent to Layer 2 and Layer 3 protocols including IEEE 802.1q, VLAN tag, Q in Q, STP, IPX, IP, etc. When used stand-alone, this converter has no access to management functions except to force Ethernet connection and apply Link Fault Pass-thru via setting of a 4-pole DIP switch.

Feature

- 1-Port 10/100Base-TX to 100Base-FX Converter
- Auto-Negotiation or forced mode
- Supports remote CPE power fail detect (dying gasp)
- Supports Far End Fault Indication (FEFI)
- Supports Link Fault Pass-Through (LFPT)
- Supports Loop Back Test
- Supports RMON counter
- Auto Laser Shutdown (ALS)
- Auto MDI/MDIX
- Forward 2046 bytes (max.) packets in switch mode
- Forward 9K jumbo packets in converter mode
- Supports Q in Q double tagged frame transparent
- Supports IEEE 802.1q Tag VLAN pass thru
- Supports local / remote In-band management (Monitor and Configure) by the SNMP manager.
- Bandwidth control (Nx32Kbps or Nx512Kbps)
- Supports IEEE 802.3x flow control (Pause)
- Fiber Hardware Reset (FHR)
- Online local / remote f/w upgrade

Specifications

Optical Interface	Connector	1 x 9 (SC, ST, FC)	Standards	IEEE 802.3, IEEE 802.3u, TS-1000	
	Data rate	125Mbps		Indications	LED (Power, FEF, FX-Link, TX-SPD, TX-Duplex, TX-Link)
	Duplex mode	Full duplex			Power Input
	Fiber	MM 50/125µm, 62.5/125µm SM 9/125µm		Power Consumption	
	Distance	MM 2km, SM 15/30/50km WDM 20/40km			Dimensions
	Wavelength	MM 1310nm, SM 1310, 1550nm WDM 1310Tx/1550Rx (type A) 1550Tx/1310Rx (type B)		Weight	
Electrical Interface	Connector	RJ45	Temperature		0 ~ 50°C (Operating), -10 ~ 70°C (Storage)
	Data rate	10Mbps, 100Mbps		Humidity	10 ~ 90% non-condensing
	Duplex mode	Half / Full duplex	Certification		CE, FCC
	Cable	10Base-T Cat.3, 4, 5, UTP 100Base-TX Cat.5, 5e or higher		MTBF	65,000 hrs

Application

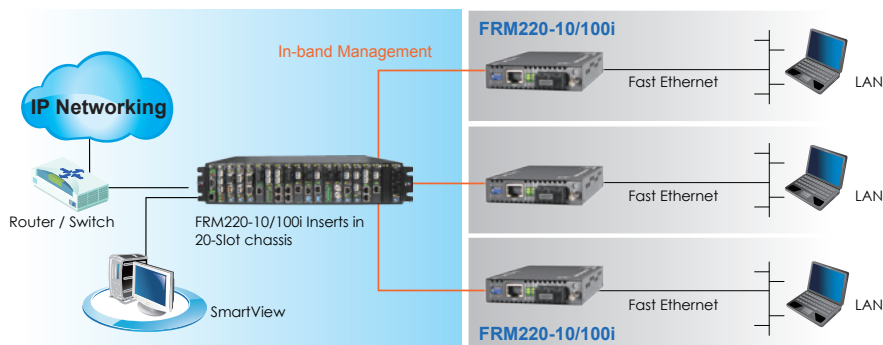

Ordering Information

Model Name	Description
FRM220-10/100i	10/100Base-TX to 100Base-FX In-band managed converter
Connector Type	Connectivity Distance
SC, ST, FC	002: 2km 015: 15km 030: 30km 050: 50km 20A: WDM 20km A type 20B: WDM 20km B type 40A: WDM 40km A type 40B: WDM 40km B type

Connector Type Connectivity Distance
FRM220 – 10/100i – □□□□□□
 Example: FRM220 – 10/100i – SC002

Note: This card must use CH01M, with serial console, to configure standalone settings. When connected as a remote to a managed central chassis, this card supports in-band management and only needs a CH01 chassis.



FRM220-10/100iS-2

Dual Channels 10/100Base-TX to 100Base-FX In-Band Managed Converter

The FRM220-10/100iS-2 is a dual (2 in 1) 10/100Base Ethernet to 100Base-FX fiber slide-in card converter based on the popular FRM220-10/100i. With advanced features like bandwidth control, this media converter is targeted for customer premises equipment in metro LAN, campus, enterprise and FTTx applications. By offering in-band management, this converter can be completely controlled and monitored from a centrally located managed rack controlling all converter settings including bandwidth control, duplex, and speed configuration. By offering two completely isolated converters on one card, this card can effectively double the conversion capacity of a rack.

Feature

- Dual independent converters 10/100Base-TX to 100Base-FX
- Auto-Negotiation or forced mode
- Auto MDI/MDIX
- Forward 2046 bytes (max.) packets in switch mode
- Supports IEEE 802.1Q Tag VLAN pass thru
- Supports Q in Q double tagged frame transparent
- Forward 9K jumbo packets in converter mode
- Supports local / remote In-band management (Monitor and Configure) by the SNMP manager
- Bandwidth control (Nx32Kbps or Nx512Kbps) & flow control (Pause)
- Supports remote CPE power fail detect (dying gasp)
- Supports Far End Fault Indication (FEFI) and Link Fault Pass-Through (LFPT)
- Supports Loop Back Test and RMON counter
- D/D function for supported SFP fiber transceiver
- Auto Laser Shutdown (ALS) and Fiber Hardware Reset (FHR)
- Online local / remote f/w upgrade

Specifications

Optical Interface	Connector	SFP LC	Standards	IEEE 802.3, IEEE 802.3u, IEEE 802.3s, TS-1000	
	Data rate	125 Mbps		Indications	LED (Power, FEF, FX-Link, TX-SPD, TX-Duplex, TX-Link)
	Duplex mode	Full duplex			Power Input
	Fiber	MM 50/125µm, 62.5/125µm. SM 9/125µm		Power Consumption	
	Distance	MM 2km, SM 15/30/50/80/120km, WDM 20/40/60/80km			Dimensions
Wavelength	MM 1310nm, SM 1310,1550nm WDM 1310Tx/1550Rx (type A) 1550Tx/1310Rx (type B)	Weight	130g		
Electrical Interface	Connector		RJ-45	Temperature	0 ~ 50°C (Operating), -10 ~ 70°C (Storage)
	Data rate	10Mbps, 100Mbps	Humidity		10 ~ 90% non-condensing
	Duplex mode	Half / Full duplex		Certification	CE, FCC, RoHS compliant
	Cable	10Base-T Cat.3, 4, 5, UTP 100Base-TX Cat.5, 5e or higher	MTBF		65,000 hrs

Application

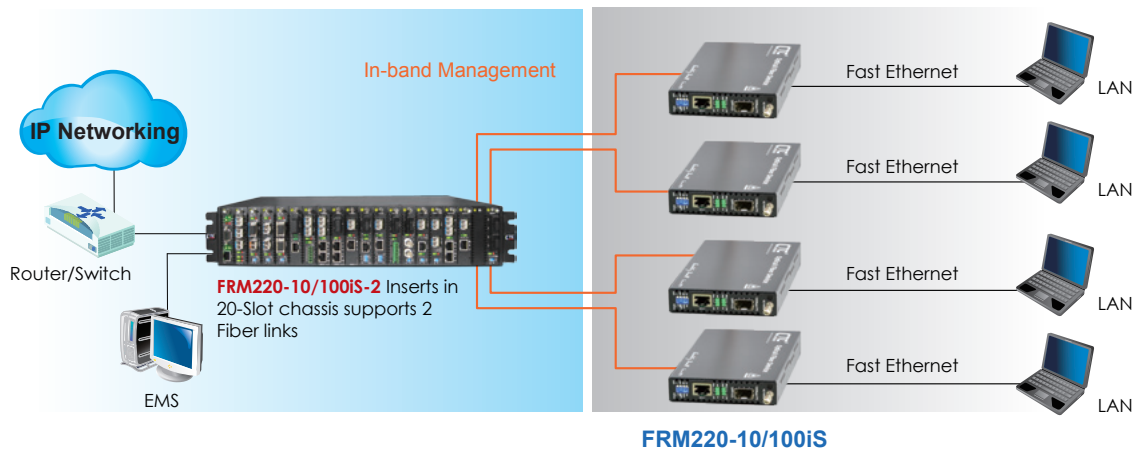

Ordering Information

Model Name	Description
FRM220-10/100iS-2	Dual converter 10/100Base-TX to 100Base-FX SFP with In-band management, (optional SFP)

Note: The Card is suitable use in CH01 standalone chassis.



FRM220-FXO-4

4x FXO over Fiber

FRM220-FXS-4

4x FXS over Fiber

FRM220-FXO/FXS-4 are 4 channel POTS (Plain Old Telephone System) over fiber converter/extender. The four POTS connection uses standard RJ-11C modular connectors for each copper pair connection. A pair of FRM220-FXO/FXS-4 is required to implement an end to end system. FXO type unit connects to a telephone line (PSTN) or PBX station line and has ability to detect ringing voltages and to act as a telephone. FXS type unit is the reciprocal unit and has ability to act as PSTN and connects to a telephone device. Two FXS cards may be connected back-to-back to provide a private "hot line". When the FRM220-FXO/FXS-4 cards are placed in the FRM220 rack with SNMP management, in-band management allows configuring and viewing the card and remote converter's status, type, version, fiber link status, on hook status and alarms. When placed in a single slot chassis and used standalone without management, the card may be configured by DIP switch.

Feature

- Extend telephone voice transmission up to 120km over fiber
- Network management via terminal, web or SNMP in FRM220 chassis
- Supports telephone voice transmission
- Supports caller ID Pass-Through
- Supports FXS to FXS hot line

Specifications

Optical Interface	Connector	SFP-LC
	Fiber	MM 62.2/125µm, 50/125µm, SM 9/125µm
		Rate: 155Mbps
	Distance	MM 2km, SM 15/30/50km, WDM 20/40km
	Wavelength	MM 1310nm, SM 1310, 1550nm
		WDM 1310Tx/1550Rx (type A)
		1550Tx/1310Rx (type B)
Indications	LED (Power, FX Link, Phone Act, Test)	
Power Input	12VDC	
Power Consumption	< 6W (FRM220-FXO-4)	
	< 12W (FRM220-FXS-4)	
Dimensions	Card: 155 x 20.8 x 88mm (D x W x H)	
Weight	120g	
Temperature	0 ~ 50°C (Operating), -10 ~ 70°C (Storage)	
Humidity	10 ~ 90% non-condensing	
Certification	CE, FCC	
MTBF	65,000 hrs	

Electrical Interface	Connector	RJ-11
	FXO mode	Impedance : 600 ohms Coding : 16 bits liner Loop Current : 10~100mA Ring Frequency : Acceptable 20 ~50Hz Insertion Loss: 0.0 ± 1.0dB at 1000Hz Impedance : 600 ohms
	FXS mode	Coding : 16 bits liner Dial: DTMF and Dial Pulse Provides 48VDC ± 4V to FXO Ringing Waveform : Sine wave Ringing Frequency : 20/25/30/35/40/45/50 Hz selectable Ring Cadence: FXS to FXS: On / 1 sec, Off / 2 sec FXO to FXS; Reproduces the cadence detected by FXO Insertion Loss 0.0 ± 1.0dB at 1000Hz REN: 4.0B(Ring Equivalence Number)

Application

Figure 1 : Automatic Ring down hotline

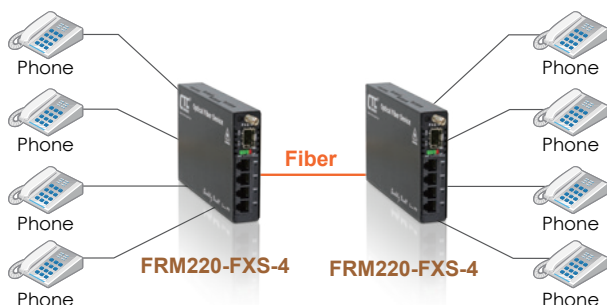
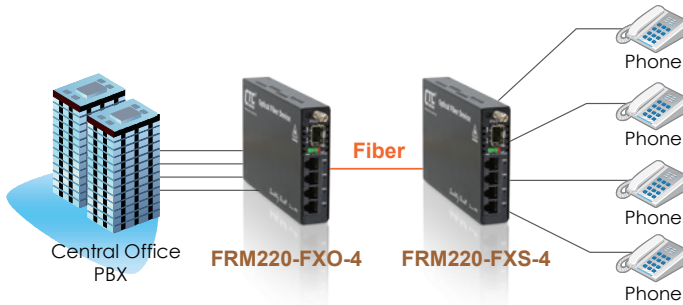

Figure 2 : Voice transmission from 2km to 120km over fiber



Ordering Information

Model Name	Description
FRM220-FXO-4	4-port FXO fiber converter SFP-LC
FRM220-FXS-4	4-port FXS fiber converter SFP-LC

Connector Type Connectivity Distance

FRM220 – FXO-4 –

Example: FRM220 – FXO-4 – SC002

Note: This card may be set by DIP switch and placed in CH01 standalone chassis. When connected as a remote to a managed central chassis, this card supports in-band management.



FRM220-FXO/FXS

FXO/FXS over Fiber

FRM220-FXO/FXS is a POTS (Plain Old Telephone System) over fiber converter/extender. The POTS connection uses a standard RJ-11C modular connector for one copper pair connection. A pair of FRM220-FXO/FXS is required to implement an end to end system. FXO mode connects to a telephone line (PSTN) or PBX station line and has ability to detect ringing voltages and to act as a telephone. FXS mode is the reciprocal unit and has ability to act as PSTN and connects to a telephone device. When the FRM220-FXO/FXS card is placed in the FRM220 rack with SNMP management, in-band management allows configuring and viewing the card and remote converter's status, type, version, fiber link status, on hook status and alarms. Both card and remote can be configured to enable or disable the port, reset the port and set the FXO or FXS mode. When configured in an FXS to FXS fashion, a private "hot line" or direct line is created. When placed in a single slot chassis and used standalone without management, the card may be configured by DIP switch.

Feature

- Extend telephone voice transmission up to 120km over fiber
- Network management via terminal, web or SNMP in FRM220 chassis
- Supports caller ID Pass-Through
- Selectable FXO or FXS mode
- Supports FXS to FXS hot line

Specifications

Optical Interface	Connector	1x9 (SC)
	Fiber	MM 62.2/125μm, 50/125μm, SM 9/125μm Rate: 155Mbps
	Distance	MM 2km, SM 15/30/50km, WDM 20/40km
	Wavelength	MM 1310nm, SM 1310, 1550nm WDM 1310Tx/1550Rx (type A) 1550Tx/1310Rx (type B)
Indications	LED (Power, FX Link, Phone Act, Test)	
Power Input	12VDC	
Power Consumption	< 6W	
Dimensions	Card: 155 x 20.8 x 88mm (D x W x H)	
Weight	120g	
Temperature	0 ~ 50°C (Operating), -10 ~ 70°C (Storage)	
Humidity	10 ~ 90% non-condensing	
Certification	CE, FCC	
MTBF	65,000 hrs	

Electrical Interface	Connector	RJ-11
	FXO mode	Impedance : 600 ohms Coding : 16 bits liner Loop Current : 10~100mA Ring Frequency : Acceptable 20 ~50Hz Insertion Loss: 0.0 ± 1.0dB at 1000Hz Impedance : 600 ohms
	FXS mode	Coding : 16 bits liner Dial: DTMF and Dial Pulse Battery Source: 48VDC ± 4V Ringing Waveform : Sine wave Ringing Frequency : 20/25/30/35/40/45/50 Hz selectable Ring Cadence: FXS to FXS : On / 1 sec, Off / 2 sec FXO to FXS; Reproduces the cadence detected by FXO Insertion Loss 0.0 ± 1.0dB at 1000Hz REN: 4.0B(Ring Equivalence Number)

Application

Figure 1 : Automatic Ring down hotline



Figure 2 : Voice Transmission from 2km to 120km over fiber



Figure 3 : Selectable FXO or FXS mode



Ordering Information

Model Name	Description
FRM220-FXO/FXS	FXO / FXS fiber converter
Connector Type	Connectivity Distance
SC,ST,FC	002: 2km 015: 15km 030: 30km 050: 50km 20A: WDM 20km A type 20B: WDM 20km B type 40A: WDM 40km A type 40B: WDM 40km B type

Note: This card may be set by DIP switch and placed in CH01 standard chassis, When connected as a remote to a managed central chassis, this card supports in-band management.



FRM220A-iMux

Ethernet over Bonded E1 NTU

2

Inverse Mux

The FRM220A-iMux is an E1 inverse multiplexer capable of bundling 4E1/ 8E1/16E1 lines for cost-effective connection of 10/100Base-TX LANs over multiple E1 transports. The FRM220A- iMux transmits 7.93Mbps (iMUX4)/ 15.87Mbps(iMUX8)/ 31.74Mbps(iMUX16) Ethernet bridge channel (GFP-F encapsulated) over multiple E1 links. The FRM220A-iMux bridges the gap between E1 and E3, allowing bridges to operate at faster rates. It also provides high speed access to SDH/SONET backbones where the only access services available are E1 lines. The FRM220A-iMux supports E1 attenuation of up to 43 dB on twisted pair or coax cable. This provides an approximate operating range up to 2km (using 22AWG). The FRM220A-iMUX fully comply the E1 specifications including ITU-T G.703 and G.823. The FRM220A-iMux features diagnostic capabilities for performing remote loopback. The operator at either end of the line may test both FRM220A-iMux NTU and the line in the digital loopback mode. The Ethernet copper interface supports auto-negotiation and auto MDI/MDIX, allowing plug-and-play Ethernet connection without any additional configuration.

Feature

- The FRM220A - iMUX connects one Fast Ethernet over 1-4 E1 links (1.984Mbps to 7.93Mbps) for iMUX4, over 1- 8 E1 links (1.984Mbps to 15.87Mbps) for iMUX8, over 1- 16 E1 links (1.984Mbps to 31.74Mbps) for iMUX16
- Built-in GFP bridge operates at WAN rate
- Maximum 220ms delay variance between E1 link
- Unbalanced E1/BNC or balanced E1/RJ45
- Fully compatible with FRM220A chassis
- SNMP management with FRM220A chassis
- LED Alarm indication & Auto-Negotiation
- Standalone RS232 console management via CH01M for iMUX4/iMUX8, CH02M for iMUX16
- Support MTU 1916 bytes

Specifications

E1 Interface	Framing	CCS+CRC (Framed)	Dimensions	Card: 155 x 42.1 x 88mm (D x W x H)	
	Standard	ITU-T G.703/G.704/G.706 & G.732, G.823		Weight	130g
	Bit rate	2.048Mbps± 50ppm (up to 5E1)		Temperature	0 ~ 50°C (Operating), -10 ~ 70°C (Storage)
	Line code	HDB3		Humidity	10 ~ 90% RH (non-condensing)
	Clock setting	Internal OSC or recovery clock		Certifications	CE, FCC
	Receive level	-43dB		MTBF	65,000 hrs
	Line impedance	75 ohm (BNC) / 120 ohm (RJ45)			
	Jitter Performance	Complies with ITU-T G.823			
	Pulse Mask	Complies with ITU-T G.703			
	Pulse amplitude	Nominal 2.37V ± 10%			
	Delay Variance	220ms			
	Connector	RJ45, BNC			
	Diagnostics	Digital remote loopback			
	Ethernet Interface	Standards		IEEE 802.3, 802.3u	
Ethernet Interface	Data rate	10/100Base-TX, Half/Full duplex			
	Connector	RJ45 10/100Base-TX			
Indications	Power, ALM, E1 signal loss, E1 Alarm(AIS, LOF, RAI, LOMF), LAN link /ACT, 10/100M, SD (100Base-FX)				
Power Input	12VDC				
Power Consumption	< 12W				

Application

-  Fiber
-  Ethernet
-  E1

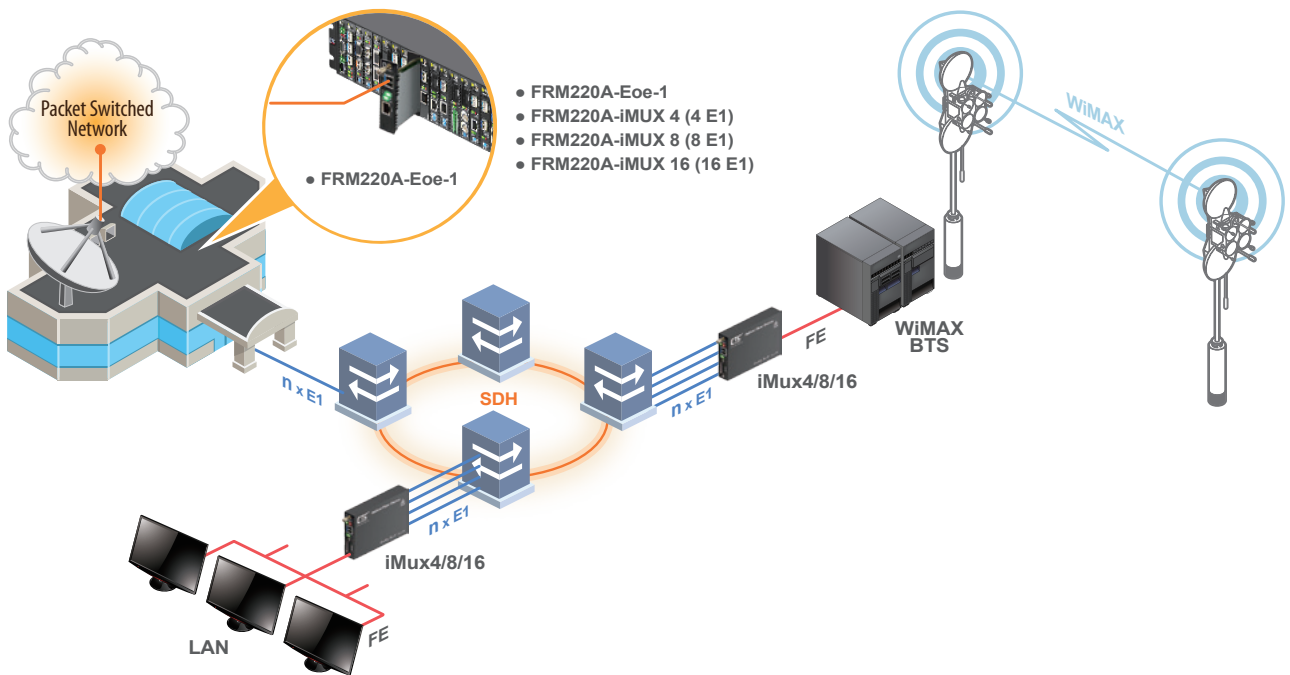

Ordering Information

Model Name	Description
FRM220A-iMux16T-R	10/100Base-TX to 16 E1 mux card with 16E1 RJ45 cable
FRM220A-iMux16T-B	10/100Base-TX to 16 E1 mux card with 16E1 BNC cable
FRM220A-iMux8T-R	10/100Base-TX to 8 E1 mux card with 8 E1 RJ45 cable
FRM220A-iMux8T-B	10/100Base-TX to 8 E1 mux card with 8 E1 BNC cable
FRM220A-iMux4T-R	10/100Base-TX to 4 E1 mux card with 4E1 RJ45 cable
FRM220A-iMux4T-B	10/100Base-TX to 4 E1 mux card with 4E1 BNC cable

Cable Type



RJ45 Cable



BNC Cable

FRM220A – iMux16T – □
 Example: FRM220A – iMux16T – R

Note: This card may be locally configured by its own console when placed in CH02M with fan.
 When connected as a remote to a managed central chassis, this card supports in-band management and only needs a CH02 chassis.



FRM220-GFOM08

8x E1/T1+ GbE Fiber Multiplexer

The FRM220-GFOM08 is an 8 channel E1/T1 fiber multiplexer with an additional Gigabit Ethernet trunk, plus order wire and clear channel RS-232, constructed as a two slot wide card for the FRM220 series. When the FRM220-GFOM08 card is placed in the FRM220 rack with NMC, the management can view the converter card's status, type, version, fiber link status and alarms. Remote, fiber connected standalone card, can also be managed through in-band management via the chassis NMC. The card can be configured to enable or disable the port, reset the port, and provide local or remote diagnostic loopback. The 1+1 redundant optical aggregate of this multiplexer employs industry standard pluggable optics (SFP) operating at 1.25Gbps data rates. The SFP modules can be chosen to support single-mode, multi-mode, single fiber bi-directional or Coarse and Dense Wave Division Multiplexing (CWDM).

Feature

- 8 channels unframed E1/T1 (transparent)
- 10/100/1000Base-T Ethernet
- Auto MDI/MDIX & Auto-Negotiation or Force Mode
- Supports flow control 802.3x & 9K jumbo packets
- Supports link fault Pass-Through for Ethernet
- One clear channel RS232 up to 250Kbps(Async)
- 1+1 fiber protection, less than 50ms
- Supports Digital Diagnostics Monitoring Interface (DDMI) SFP
- AIS on signal loss on E1/T1 and fiber port
- Loopback test on E1/T1, RS232, fiber ports
- Supports local or remote In-band management (Monitor or Configure status) by SNMP manager and console port
- Supports Order wire Ear / Microphone port
- Supports On-Line F/W upgrade & Dying Gasp

Specifications

E1/T1 ports	Framing	Unframed (transparent)
	Bit Rate	E1:2.048 Mb/s , T1: 1.544Mb/s
	Line Code	E1:AMI/HDB3, T1: AMI/B8ZS
	Line Impedance	E1: Unbalanced 75 ohms (BNC)
		E1: Balanced 120 ohms (RJ-45) T1: Balanced 100 ohms (RJ-45)
	Receiver sensitivity	Short haul
	"Pulse" Amplitude	Nominal 2.37V+/-10% for 75 ohms
		Nominal 3.00V+/-10% for 120 ohms
	"Zero" Amplitude	+/-0.3V
	Internal Timing	+/-30 ppm
	Jitter Performance	According to ITU-T G.823
	Performance monitoring	According to ITU-T G.821
Standards	ITU-T G.703, G.704, G.706 and G.732	
Interface Connectors	RJ-45	
E1/T1 ports	Test Loops	LLB (Local Loop Back) NELB (Near End Loop Back)

E1/T1 ports	Test Loops	RLB (Remote Loop Back) RRLB (Request Remote Loop Back)
	Fiber	Connector SFP LC Data Rate 1.25 Gbps
Ethernet	Interface Type	10/100/1000Base-T
	Connector	RJ-45
	Standards	IEEE 802.3, 802.3u, 802.3ab
Indications	Duplex modes	full/half
	Power Input	FX1 Link, FX2 link, E1/T1 Mode/Link/Loopback test, Order wire phone indicator, LAN Link/Speed.
Power Consumption	12VDC	< 12W
Dimensions	Card: 155 x 42.1 x 88mm (D x W x H)	
Weight		200g
Temperature		0 ~ 50°C (Operating), -10 ~ 70°C (Storage)
Humidity		10 ~ 90% RH (non-condensing)
Certifications		CE, FCC

Application

Managed 8E1/T1 + Gigabit Ethernet Fiber Optical Multiplexer

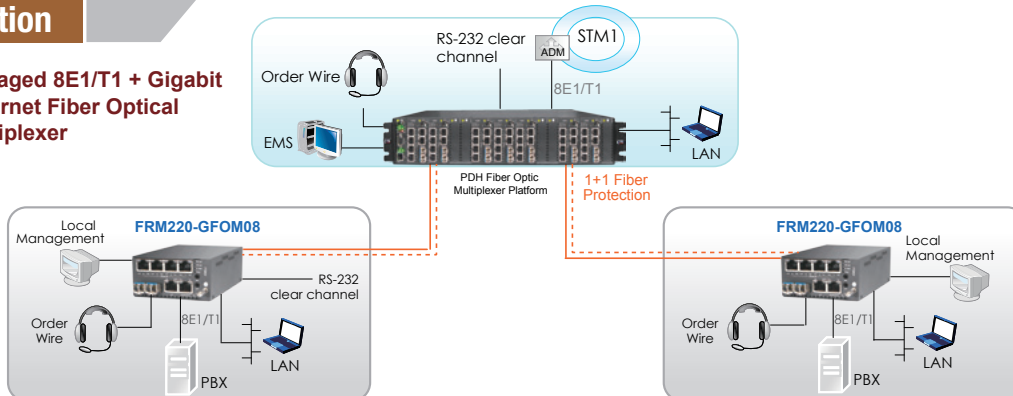

Ordering Information

Model Name	Description
FRM220-GFOM08-SR	8x E1/T1 RJ45 and 1000Mbps Ethernet Fiber Mux with 4x2E1 RJ45 cable, optional SFP module (Model : SFS-70xx-xx)
FRM220-GFOM08-SB	8x E1 BNC and 1000Mbps Ethernet Fiber Mux with 4x2E1 BNC cable, optional SFP module (Model : SFS-70xx-xx)



2E1 RJ45 cable

Note: This card may be locally configured by its own console when placed in CH02M with fan. When connected as a remote to a managed central chassis, this card supports in-band management and only needs a CH02M chassis.



FRM220-GFOM04

4X E1/T1 + GbE Fiber Multiplexer

The FRM220-GFOM04 is a 4 channel E1/T1 fiber multiplexer with an additional Gigabit Ethernet trunk, plus order wire and clear channel RS-232, constructed as a two slot wide card for the FRM220 series. When the FRM220-GFOM04 card is placed in the FRM220 rack with NMC, the management can view the converter card's status, type, version, fiber link status and alarms. Remote, fiber connected standalone card, can also be managed through in-band management via the chassis NMC. The card can be configured to enable or disable the port, reset the port, and provide local or remote diagnostic loopback. The 1+1 redundant optical aggregate of this multiplexer employs industry standard pluggable optics (SFP) operating at 1.25Gbps data rates. The SFP modules can be chosen to support single-mode, multi-mode, single fiber bi-directional or Coarse and Dense Wave Division Multiplexing (CWDM and DWDM).

Feature

- 4 channels unframed E1/T1 (transparent)
- 10/100/1000Base-T Ethernet
- Auto MDI/MDIX & Auto-Negotiation or Force Mode
- Supports flow control 802.3x & 9K jumbo packets
- Supports link fault Pass-Through for Ethernet
- One clear channel RS232 up to 250Kbps(Async)
- 1+1 fiber protection, less than 50ms
- Supports Digital Diagnostics Monitoring Interface (DDMI) SFP
- AIS on signal loss on E1/T1 and fiber port
- Loopback test on E1/T1, RS232, fiber ports
- Supports local or remote In-band management (Monitor or Configure status) by SNMP manager and console port
- Supports Order wire Ear / Microphone port
- Supports On-Line F/W upgrade & Dying Gasp

Specifications

E1/T1 ports	Framing	Unframed (transparent)
	Bit Rate	E1:2.048 Mb/s , T1: 1.544Mb/s
	Line Code	E1:AMI/HDB3, T1: AMI/B8ZS
	Line Impedance	E1: Unbalanced 75 ohms (BNC)
		E1: Balanced 120 ohms (RJ-45)
		T1: Balanced 100 ohms (RJ-45)
	Receiver sensitivity	Short haul
	"Pulse" Amplitude	Nominal 2.37V+/-10% for 75 ohms
		Nominal 3.00V+/-10% for 120 ohms
	"Zero" Amplitude	+/-0.3V
	Internal Timing	+/-30 ppm
	Jitter Performance	According to ITU-T G.823
	Performance monitoring	According to ITU-T G.821
Standards	ITU-T G.703, G.704, G.706 and G.732	
Interface Connectors	RJ-45	
E1/T1 ports	Test Loops	LLB (Local Loop Back) NELB (Near End Loop Back)

E1/T1 ports	Test Loops	RLB (Remote Loop Back) RRLB (Request Remote Loop Back)
Fiber	Connector	SFP LC
	Data Rate	1.25 Gbps
Ethernet	Interface Type	10/100/1000Base-T
	Connector	RJ-45
	Standards	IEEE 802.3, 802.3u, 802.3ab
	Duplex modes	full/half
Indications	FX1 Link, FX2 link, E1/T1 Mode/Link/Loopback test, Order wire phone indicator, LAN Link/Speed.	
Power Input	12VDC	
Power Consumption	< 12W	
Dimensions	Card: 155 x 42.1 x 88mm (D x W x H)	
Weight	200g	
Temperature	0 ~ 50°C (Operating), -10 ~ 70°C (Storage)	
Humidity	10 ~ 90% RH (non-condensing)	
Certifications	CE, FCC	

Application

Managed 4E1/T1 + Gigabit Ethernet Fiber Optical Multiplexer

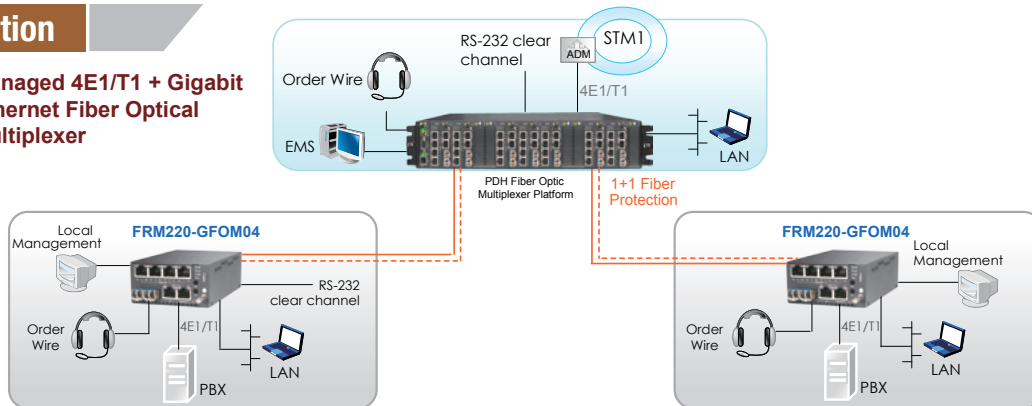

Ordering Information

Model Name	Description
FRM220-GFOM04-SR	4x E1/T1 RJ-45 and 10/100/1000Base-T Ethernet Fiber Optic Multiplexer (optional SFP module)
FRM220-GFOM04-SB	4x E1 BNC and 10/100/1000Base-T Ethernet Fiber Optic Multiplexer (optional SFP module)

Connector Type
FRM220 – GFOM04 – □□
 Example: FRM220 – GFOM04 – SR

Note: This card may be locally configured by its own console when placed in CH02M with fan. When connected as a remote to a managed central chassis, this card supports in-band management and only needs a CH02M chassis.



FRM220-FOM04

4x E1/T1+ FE Fiber Multiplexer

The FRM220-FOM04 is a 4 channel E1/T1 fiber multiplexer with an additional wire speed 100M Ethernet trunk, plus order wire and clear channel RS-232, constructed as a two slot wide card for the FRM220 series. When the FRM220-FOM04 card is placed in the FRM220 rack with NMC, the management can view the converter card's status, type, version, fiber link status and alarms. Remote, fiber connected standalone card, can also be managed through in-band management via the chassis NMC. The card can be configured to enable or disable the port, reset the port, and provide local or remote diagnostic loopback. The 1+1 redundant optical aggregate of this multiplexer employs industry standard pluggable optics (SFP) operating at OC3/STM- 1 data rates (155M). The SFP modules can be chosen to support single-mode, multi-mode, single fiber bi-directional or Coarse and Dense Wave Division Multiplexing (CWDM and DWDM).

Feature

- 4 channels unframed E1/T1 (transparent)
- 10/100Base-TX Ethernet (100M wirespeed)
- Auto MDI/MDIX & Auto-Negotiation or Force Mode
- Supports flow control 802.3x & 9K jumbo packets
- Supports link fault Pass-Through for Ethernet
- One clear channel RS232 up to 250Kbps(Async)
- 1+1 fiber protection, less than 50ms
- Supports Digital Diagnostics Monitoring Interface (DDMI) SFP
- AIS on signal loss on E1/T1 and fiber port
- Loopback test on E1/T1, RS232, fiber ports
- Supports local or remote In-band management (Monitor or Configure status) by SNMP manager and console port
- Supports Order wire Ear / Microphone port
- Supports On-Line F/W upgrade & Dying Gasp

Specifications

E1/T1 ports	Framing	Unframed (transparent)
	Bit Rate	E1:2.048 Mb/s , T1: 1.544Mb/s
	Line Code	E1:AMI/HDB3, T1: AMI/B8ZS
	Line Impedance	E1: Unbalanced 75 ohms (BNC cable)
		E1: Balanced 120 ohms (RJ-45)
		T1: Balanced 100 ohms (RJ-45)
	Receiver sensitivity	Short haul
	"Pulse" Amplitude	Nominal 2.37V+/-10% for 75 ohms Nominal 3.00V+/-10% for 120 ohms
	"Zero" Amplitude	+/-0.3V
	Internal Timing	+/-30 ppm
	Jitter Performance	According to ITU-T G.823
	Performance monitoring	According to ITU-T G.821
Standards	ITU-T G.703, G.704, G.706 and G.732	
Interface Connectors	RJ-45	
E1/T1 ports	Test Loops	LLB (Local Loop Back) NELB (Near End Loop Back)

E1/T1 ports	Test Loops	RLB (Remote Loop Back) RRLB (Request Remote Loop Back)
Fiber	Connector	SFP LC
	Data Rate	155 Mbps
Ethernet	Interface Type	10/100Base-TX
	Connector	RJ-45
	Standards	IEEE 802.3, 802.3u
	Duplex modes	full/half
Indications	FX1 Link, FX2 link, E1/T1 Mode/Link/Loopback test, Order wire phone indicator, LAN Link/Speed.	
Power Input	12VDC	
Power Consumption	< 7W	
Dimensions	Card: 155 x 42.1 x 88mm (D x W x H)	
Weight	200g	
Temperature	0 ~ 50°C (Operating), -10 ~ 70°C (Storage)	
Humidity	10 ~ 90% RH (non-condensing)	
Certifications	CE, FCC	

Application

Managed 4E1/T1 + Fast Ethernet Fiber Optical Multiplexer

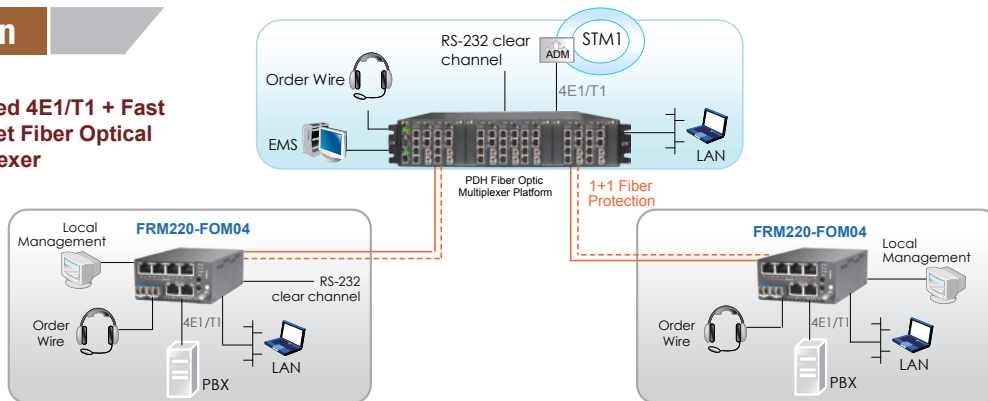

Ordering Information

Model Name	Description
FRM220-FOM04-SR	4 x E1/T1 RJ-45 and 100Mbps Ethernet Fiber Optic Multiplexer(optional SFP module)
FRM220-FOM04-SB	4x E1 BNC and 100Mbps Ethernet Fiber Optic Multiplexer(optional SFP module)

FRM220 – FOM04 –
 Example: FRM220 – FOM04 – SR

Note: This card may be locally configured by its own console when placed in CH02M with fan. When connected as a remote to a managed central chassis, this card supports in-band management and only needs a CH02M chassis.



FRM220-FOM01

E1/T1 + FE Fiber Multiplexer

The FRM220-FOM01 is a single channel E1/T1 fiber multiplexer with an additional wire speed 100M Ethernet trunk, plus clear channel RS-232, for placement the FRM220 series. When the FRM220-FOM01 card is placed in the FRM220 rack with NMC, the management can view the converter card's status, type, version, fiber link status and alarms. Remote, fiber connected standalone card, can also be managed through in-band management via the chassis NMC. The card can be configured to enable or disable the port, reset the port, and provide local or remote diagnostic loopback. The optical aggregate of this multiplexer employs either a fixed transceiver or industry standard pluggable optics (SFP) operating at OC3/STM-1 data rates (155M). The SFP modules can be chosen to support single-mode, multi-mode, single fiber bi-directional or Coarse and Dense Wave Division Multiplexing (CWDM and DWDM).

Feature

- 1 channel unframed E1/T1 (transparent)
- 10/100Base-TX Ethernet (100M wirespeed)
- Auto MDI/MDIX & Auto-Negotiation or Force Mode
- Supports flow control & 9K jumbo packets
- Supports link fault Pass-Through for Ethernet
- Supports Digital Diagnostics Monitoring Interface (DDMI) SFP
- Loopback test on E1/T1, fiber ports
- Supports local or remote In-band management by SNMP manager
- Local management by console port via FRM220-CH01M chassis
- Supports On-Line F/W upgrade & Dying Gasp

Specifications

E1/T1 ports	Framing	Unframed (transparent)
	Bit Rate	E1:2.048 Mb/s, T1: 1.544Mb/s
	Line Code	E1:AMI/HDB3, T1: AMI/B8ZS
	Line Impedance	E1: Unbalanced 75 ohms (BNC)
		E1: Balanced 120 ohms (RJ-45)
		T1: Balanced 100 ohms (RJ-45)
	Receiver sensitivity	Short haul
	"Pulse" Amplitude	Nominal 3.37V+/-10% for 75 ohms
		Nominal 3.00V+/-10% for 120 ohms +/-0.3V
	"Zero" Amplitude	w/external clock card option
	Internal Timing	+/-30 ppm
	Jitter Performance	According to ITU-T G.823
	Performance monitoring	According to ITU-T G.821
	Standards	ITU-T G.703, G.704, G.706 and G.732
E1/T1 ports	Interface Connectors	RJ-45
	Test Loops	LLB (Local Loop Back)
		RLB (Remote Loop Back)

Fiber	Connector	SFP LC
	Data Rate	155 Mbps
Ethernet	Interface Type	10/100Base-TX
	Connector	RJ-45
	Standards	IEEE 802.3, 802.3u
	Duplex modes	full/half
Indications	Power FX Link, E1/T1 Mode/Link/Loopback test, LAN Link/Speed	
Power Input	12VDC	
Power Consumption	< 4W	
Dimensions	Card: 155 x 20.8 x 88mm (D x W x H)	
Weight	130g	
Temperature	0 ~ 50°C (Operating), -10 ~ 70°C (Storage)	
Humidity	10 ~ 90% RH (non-condensing)	
Certifications	CE, FCC	

Application

Managed E1/T1 + Fast Ethernet Fiber Optical Multiplexer

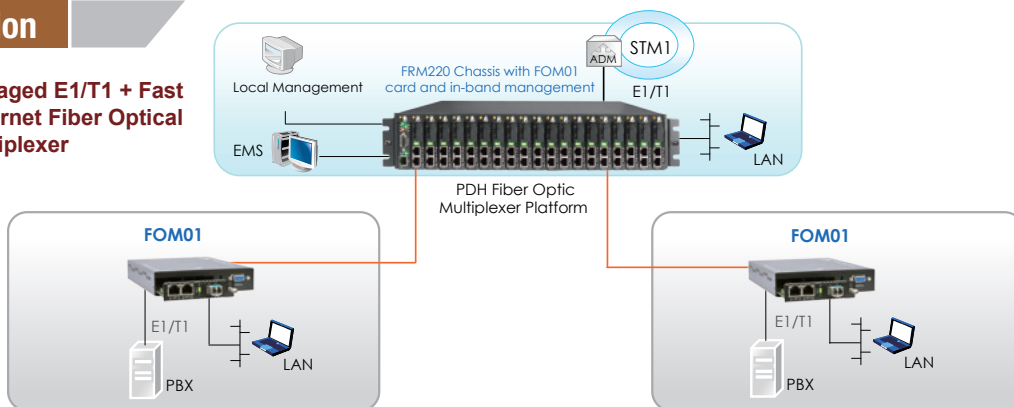

Ordering Information

Model Name	Description
FRM220-FOM01-SR	E1/T1 RJ-45 and 100Mbps Ethernet Fiber Optic Multiplexer (optional SFP module)
FRM220-FOM01-SB	E1 BNC and 100Mbps Ethernet Fiber Optic Multiplexer (optional SFP module)

Connector Type Connectivity Distance

FMC220 – FOM01 – –

Example: FMC220 – FOM01 – SR – SC002

Note: This card must use CH01M with serial console, to configure standalone settings. When connected as a remote to a managed central chassis, this card supports in-band management and only needs a CH01 chassis.



FRM220-DS3/E3

DS3/E3 over Fiber

The FRM220-DS3/E3 is a fiber modem that works in pairs to transparently extend DS3, E3 or STS-1 transmissions over optical fiber. By utilizing pluggable SFP transceivers (155Mbps), these converters may be easily deployed on multimode or single mode fiber, at a distance up to 120km, or over a single core fiber using BiDi (WDM) SFP modules. The DS3/E3 connections utilize industry standard BNC connections for transmit and receive via coaxial cables. When the FRM220-DS3/E3 card is used standalone in a single slot chassis, DIP switches may be used for configuration and loopback control. When placed in a single slot chassis with console port, an easy to maneuver user menu is available via terminal to configure, monitor, and run diagnostic loop back functions. The EOC (embedded operations channel) allows in-band management to control the remotely connected modem over a working fiber link. When the FRM220-DS3/E3 card is placed in the FRM220 rack with SNMP management, the management can configure and view the local and remote converter cards' status, type, version, fiber link status and alarms.

Feature

- In-band network Managed via Terminal, web or SNMP in FRM220 chassis
- DS3/E3 Coax (BNC) to Fiber SFP fiber modem
- Supports AIS (Alarm Indication Signal)
- User selectable E3 or DS3 setting
- Electrical and optical Loop back tests
- Standalone RS232 console management via CH01M

Specifications

Optical Interface	Connector	SFP : LC (Uses standard 100Base-X/OC-3 SFP)	Electrical Interface	Connector	75 ohm Coax, TX output min: +2.5dBm max : +9.1dBm
	Data Rate	DS3/T3 = 44.7 Mbps; E3 = 34.4 Mbps		RX input min: -9.7dBm, max +10.5dBm	
Line Coding	Distance	MM 2km, SM 15/30/50/80/120km, WDM 20/40/60/80km	Standards	ANSI, ITU-TS, ETSI, AT&T, G.703, G.921 & G.955	
	Wavelength	1310nm, 1550nm, CWDM 1471nm ~ 1611nm	Indications	Power, Coax link, coax loop-back, AIS on coax link; FX link, fiber loop-back ,AIS on FX link	
	Dimensions	Card: 155 x 20.8 x 88mm (D x W x H)	Power Input	12VDC	
Weight	120g	Power Consumption	< 6W		
Temperature	0 ~ 50°C (Operating), -10 ~ 70°C (Storage)				
Certification	CE, FCC				

Application

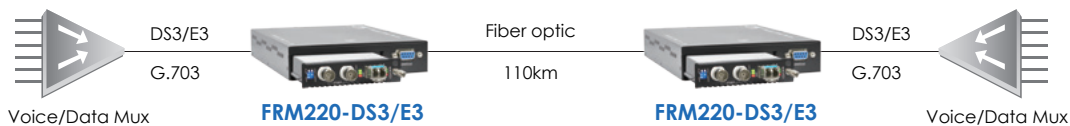

Integrate Voice & Data on Network

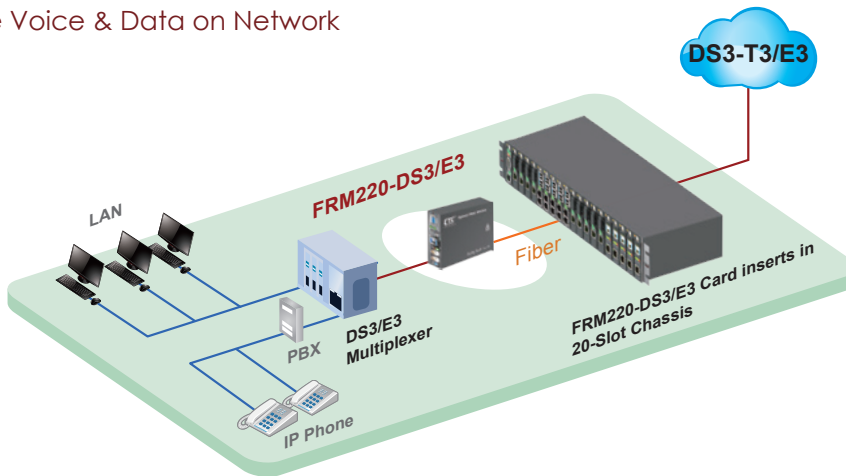

Ordering Information

Model Name	Description
FRM220-DS3/E3	DS3/E3 Coax (BNC) to Fiber SFP fiber media converter

Note: This card must use CH01M, with serial console, to configure standalone settings. When connected as a remote to a managed central chassis, this card supports in-band management and only needs a CH01 chassis.



FRM220-Serial RS232/485 over Fiber

The FRM220-Serial provides a fiber modem solution to extend asynchronous RS-232, RS-422 or RS-485 transmission distance up to 2km over multimode fiber or up to 120km over single mode fiber. The converter is equipped with multiple interface circuits for connection to RS-232 or RS485/422 (2 or 4 wire, full or half duplex). The FRM220-Serial secures data transmission over EMI resistant fiber at speeds up to 256kbps for RS-232 or up to 1024kbps for RS485/422. When the FRM220-Serial/485 card is placed in the FRM220 rack with SNMP management, in-band management allows configuring and viewing the card and remote converter's status, type, version, fiber link status, data link status and alarms. When placed in a single slot chassis and used standalone without management, the card may be configured by DIP switches.

Feature

- Extend asynchronous serial transmission up to 120km over fiber
- In-band network management via terminal, Web or SNMP in FRM220-CH20 chassis
- Software selectable data interface for RS-232/ 485
- Software selectable three or five wires RS-232
- Speeds up to 256kbps for RS-232 (Async. mode)
- Speeds up to 1Mbps for RS-485
- Standalone RS232 console management via CH01M
- Software selectable two wires (half duplex) or four wires (full duplex) RS-485

Specifications

Optical Interface	Connector	SFP LC	Electrical Interface	Connector	6 pins Terminal block
	Data rate	36.864Mbps		Data Signal Formats	RS-485 2-wire RS-232 RTS/CTS 5-wire RS-232 3-wire
	Line coding	Scrambled NRZ		Baud Rate	RS-422, RS-485 up to 1024kbps RS-232 up to 256kbps
	Bit Error Rate	Less than 10 ⁻¹⁰		Bit Error Rate	Less than 10 ⁻¹⁰
	Fiber	MM 62.2/125µm, 50/125µm SM 9/125µm		Power Consumption	< 6W
	Distance	MM 2km, SM 15/30/50km WDM 20/40km		Dimensions	Card: 155 x 20.8 x 88mm (D x W x H)
	Wavelength	MM 1310nm, SM 1310, 1550nm WDM 1310Tx/1550Rx (type A) 1550Tx/1310Rx (type B)		Weight	130g
Standards	EIA/TIA RS-485, RS-232	Temperature	0 ~ 50°C (Operating), -10 ~ 70°C (Storage)		
LEDs	Power, FX Link, DI, DO, Test	Humidity	10 ~ 90% non-condensing		
Power Input	12VDC	Certification	CE, FCC		
		MTBF	65,000 hrs		

Application

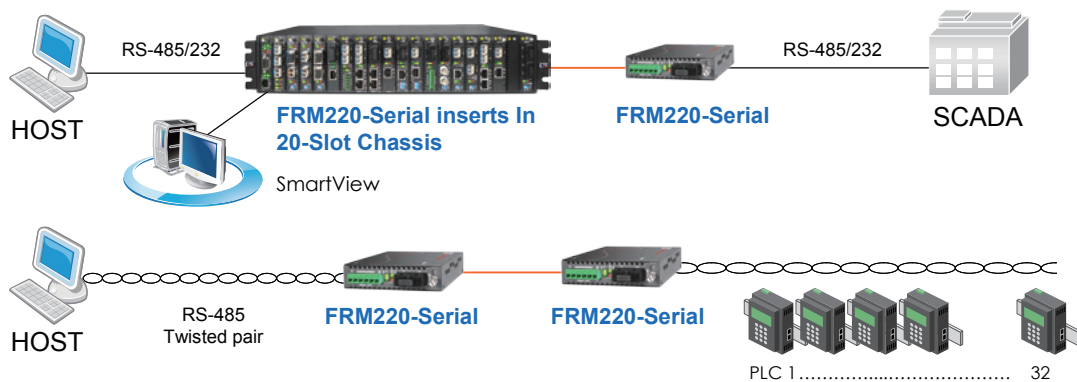

Ordering Information

Model Name	Description
FRM220-Serial	RS-232/485 fiber converter
FRM220-Serial-SFP	RS-232/485 fiber converter (SFP module not included)
Connector Type	Connectivity Distance

SC,ST,FC (Not Applicable for SFP Type) 002: 2km 015: 15km 030: 30km 050: 50km
 20A: WDM 20km A type 20B: WDM 20km B type 40A: WDM 40km A type 40B: WDM 40km B type

Connector Type Connectivity Distance
FRM220 – Serial –
 Example: FRM220 – E1/T1R – SC002

Note: This card may be set by DIP switch and placed in CH01 chassis, or set by serial console if placed in CH01M chassis. When connected as a remote to a managed central chassis, this card supports in-band management and only needs a CH01 chassis.



FRM220-FTEC

E1/T1 Cross Rate Converter

2

E1/T1 Cross Rate Converter

The FRM220-FTEC is a T1 (US Standard) /E1 (European Standard) converter and timeslot cross connect which enables conversion between one T1 signal and one E1 signal. T1 and E1 signals with framing employ u-Law and A-Law compander encoding principles respectively and encode those analog (voice) signals into 64kbps digital data. The T1 interface supports D4(SF) or ESF frame formats with B8ZS or AMI line code. The E1 interface supports CCS (PCM31) or CAS (PCM30) framing without CRC-4 and framing with CRC-4. The line coding is HDB3.

Tests and diagnostics can easily be performed from the local console interface or via Web based management of the FRM220. Diagnostics include T1 local/remote and E1 local/remote loop back. When placed in a single slot chassis and used standalone without management, the card may be configured by DIP switches.

Feature

- Converts between T1 and E1 data and signaling
- Enable equipment to operate at T1 and E1 rates
- Supports G.802 Annex B (T1 over E1)
- Configures A-law/ μ -law and signaling conversion
- Transparent conversion at 64kbps timeslot level
- Controlled slip for buffer over or under flow
- 24 time slots of T1 Nx64 can be inserted into E1 Nx64, 30/CAS or 31/CCS timeslots

Specifications

E1 Interface	Framing	CAS/PCM30 or CCS/PCM31 selectable	LEDs	PWR, Sys, Test, T1/E1		
	Bit rate	2.048Mbps		Standard	ITU-T G.703, G.704, G.706, G.823, G.824, ANSI T1.403	
	Line Code	HDB3			Power	12VDC
	Line Impedance	75 ohm (BNC) / 120 ohm (RJ-45)		Power Consumption		< 6W
	CRC check	CRC-4 enable/disable			Dimensions	Card: 155 x 20.8 x 88mm (D x W x H)
	Pulse amplitude	Nominal 2.37V \pm 10% for 75ohm Nominal 3.00V \pm 10% for 120ohm		Weight		130g
	Zero amplitude	\pm 0.1V			Temperature	0 ~ 50°C (Operating), -10 ~ 70°C (Storage)
	Connector	RJ-45		Humidity		10 ~ 90% non-condensing
	T1 Interface	Framing			D4, ESF selectable	Certification
		Bit rate		1.544Mbps	MTBF	
Line Code		B8ZS / AMI				
Equalization		0 ~ 655 feet settable				
		Voice channel sample rule μ -Law				
CRC check		CRC-6 when ESF				
Line Impedance		100 ohms				
Transmit Pulse level		3.0V \pm 10%,				
Receive signal level	0 ~ -10dB					
Connector	RJ-45					

Application



Ordering Information

Model Name	Description
FRM220-FTEC	E1/T1 Cross rate converter

Note: This card must use CH01M, with serial console, to configure standalone settings. For standalone SNMP management, place this card in CH02/NMC chassis.



FRM220-E1/DATA

E1 to Data

The FRM220-E1/Data is a single port G.703/704 Fractional E1 DSU/CSU card for the FRM220/220A Series Platform Media Converter Rack. The converter supports Unframed, PCM31, PCM31+CRC4, PCM30, and PCM30+CRC4 framing modes. The clock source may be selected internally, recovered from received E1 signal, externally from the Data port or transparent. The data port interface utilizes a single hi-density 26pin connector. Cable solutions are provided for RS-530/449, X.21, V.35 and RS-232. The unit can recognize the cable type attached and automatically self-configure the interface circuits. Choosing from one of two model types, the E1 connection is either unbalanced 75 ohm with two BNC connectors or balanced 120 ohm with one RJ-45 connector. When the FRM220-E1/Data card is placed in the FRM220 rack with SNMP management, the management can view the converter card's status, type, version, E1 link status and alarms. The card can be configured to enable or disable the port, reset the card, set clocking, frame mode, interface type and provide analog or digital diagnostic loopbacks. A unique feature of the FRM220-E1/Data is the use of a common card design which may either be inserted in the FRM220-CH01 single slot chassis as a stand-alone modem or as a card when placed in the FRM220-CH20 managed rack.

Feature

- Supports Fractional E1 and Unframed E1 services with V.35/X21/RS530 adapter cable
- I/O connectors all located on front panel
- Multiple clock source selection and remote loopback
- (Internal or External: E1 recovery, DTE or DCE)
- Unbalanced E1/BNC or balanced E1/RJ45
- Fully compatible with FRM220-CH20 and FRM220A chassis
- SNMP management with FRM220-CH20 chassis
- LED Alarm indication
- Standalone RS232 console management via CH01M

Specifications

E1 Interface	Framing	Framed/Unframed	Serial Interface	Standards	ITU-T, E1A
	Standards	ITU-T G.703/G.704/G.706 & G.732, G.823		Data rate	Nx56 / Nx64
	Bit rate	2.048Mbps± 50ppm		Connector	HDB26F w/ adapter cable for Data
	Line code	HDB3		LEDs	Power, TD, RD, RTS, DCD, TX Clock loss, Signal loss, Sync loss, Alarm, test error
	Clock setting	Internal OSC or recovery clock			Power
	Receive level	-43dB		Power Consumption	
	Line impedance	75 ohm (BNC) / 120 ohm (RJ45)			Dimensions
	Jitter	Complies with ITU-T G.823		Weight	
	Performance				Temperature
	Pulse Mask	Complies with ITU-T G.703		Humidity	
	Pulse amplitude	Nominal 2.37V ± 10%			Certifications
	Delay Variance	8ms		MTBF	
	Connector	BNC / RJ-45			
Diagnostics	Digital remote loopback				

Application

Managed E1 Access Unit

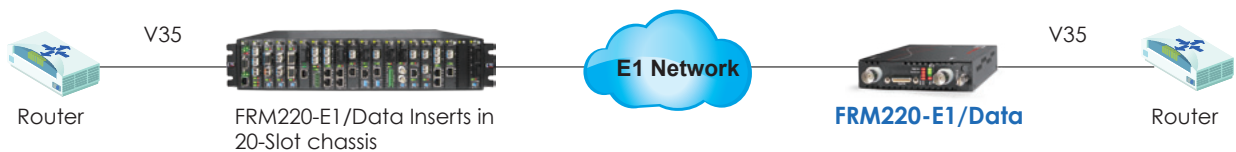

Ordering Information

Model Name	Description
FRM220-E1/V35-R	V35 to framed E1 RJ-45 with V35 cable
FRM220-E1/V35-B	V35 to framed E1 BNC with V35 cable
FRM220-E1/X21-R	X21 to framed E1 RJ-45 with X21 cable
FRM220-E1/X21-B	X21 to framed E1 BNC with X21 cable
FRM220-E1/RS530-R	RS530 to framed E1 RJ-45 with RS530 cable
FRM220-E1/RS530-B	RS530 to framed E1 BNC with RS530 cable
FRM220-E1/RS449-R	RS449 to framed E1 RJ-45 with RS449 cable
FRM220-E1/RS449-B	RS449 to framed E1 BNC with RS449 cable
FRM220-E1/RS232-R	RS232 to framed E1 RJ-45 with RS232 cable
FRM220-E1/RS232-B	RS232 to framed E1 BNC with RS232 cable

FRM220 - □□ / □□□ - □
 Example: FRM220 - E1/V35 - R

Note: This card may be set by DIP switch and placed in CH01 chassis, or set by serial console if placed in CH01M chassis. For standalone SNMP management, place this card in CH02/NMC chassis.



FRM220A-Eoe1

Ethernet Bridge over E1

- HDLC
- MTU 1522bytes
- Framed / Unframed E1

The FRM220A-Eoe1 is an Ethernet over E1 Bridge for cost-effective connection of 10/100Base-TX or 100Base-FX LANs over a single E1 transport. By using standard HDLC encapsulation, the FRM220A-Eoe1 is able to transmit up to a 2M bits Ethernet over an E1 link. The FRM220A-Eoe1 supports an E1 attenuation of up to 43 dB on twisted pair or coax cable, which provides an approximate operating range up to 2km (using 22AWG). The FRM220A-Eoe1 fully meets E1 specifications including ITU-T G.703 and G.823. The FRM220A-Eoe1 features diagnostic capabilities for performing remote loopback. The operator at either end of the line may test both the FRM220A-Eoe1 and the line in the digital loopback mode. The Ethernet copper interface supports auto-negotiation and auto MDI/MDIX, allowing plug-and-play Ethernet connection without any additional configuration. When placed in FRM220A system, the Ethernet may be aggregated to the chassis's built in Ethernet switch. When placed in a single slot chassis and used standalone without management, the card may be configured by DIP switch.

Feature

- Connects one Fast Ethernet over E1 links (64k~2048Kbps)
- Built-in HDLC bridge operates at WAN rate
- Auto-Negotiation
- Unbalanced E1/BNC or balanced E1/RJ45
- Fully compatible with FRM220A and FRM220 chassis
- SNMP management with FRM220A and FRM220 chassis
- LED Alarm indication
- Standalone RS232 console management via CH01M

Specifications

Optical Interface	Connector	1x9 (SC)
	Fiber	MM 62.2/125µm, 50/125µm, SM 9/125µm Rate: 155Mbps
	Distance	MM 2km, SM 15/30/50km, WDM 20/40km
	Wavelength	MM 1310nm, SM 1310, 1550nm WDM 1310Tx/1550Rx (type A) 1550Tx/1310Rx (type B)
Indications	LED (Power, FX Link, Phone Act, Test)	
Power Input	12VDC	
Power Consumption	< 6W	
Dimensions	Card: 155 x 20.8 x 88mm (D x W x H)	
Weight	120g	
Temperature	0 ~ 50°C (Operating), -10 ~ 70°C (Storage)	
Humidity	10 ~ 90% non-condensing	
Certification	CE, FCC	
MTBF	65,000 hrs	

Electrical Interface	Connector	RJ-11
	FXO modle	Impedance : 600 ohms Coding : 16 bits liner Loop Current : 10~100mA Ring Frequency : Acceptable 20 ~50Hz Insertion Loss: 0.0 ± 1.0dB at 1000Hz Impedance : 600 ohms
	FXS modle	Coding : 16 bits liner Dial: DTMF and Dial Pulse Battery Source: 48VDC ± 4V Ringing Waveform : Sine wave Ringing Frequency : 20/25/30/35/40/45/50 Hz selectable Ring Cadence: FXS to FXS: On / 1 sec, Off / 2 sec FXO to FXS; Reproduces the cadence detected by FXO Insertion Loss 0.0 ± 1.0dB at 1000Hz REN: 4.0B(Ring Equivalence Number)

Application

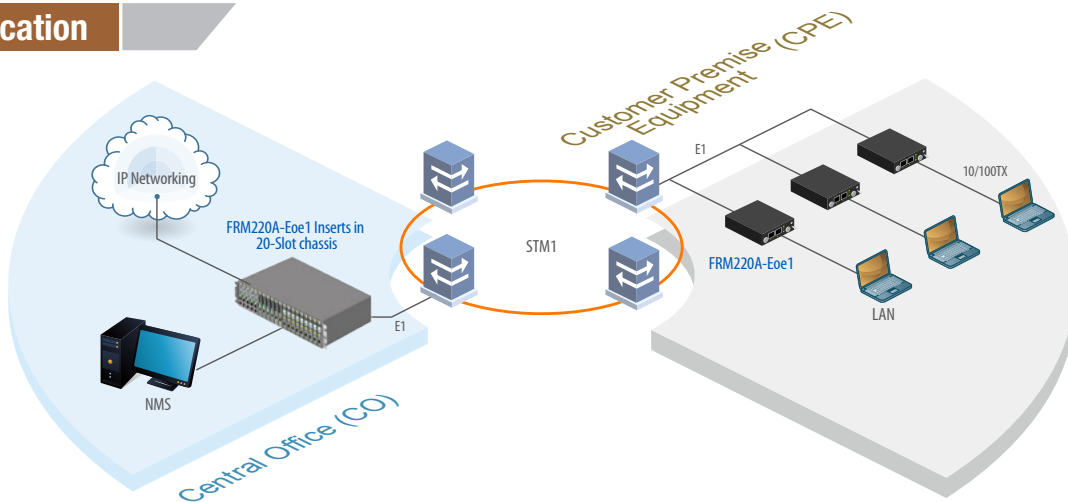

Ordering Information

Model Name	Description
FRM220A-Eoe1	10/100Base-TX to E1 HDLC bridge

Note: This card may be set by DIP switch and placed in CH01 chassis, or set by serial console if placed in CH01M chassis. When connected as a remote to a managed central chassis, this card supports in-band management and only needs a CH01 chassis.



FRM220-E1/T1

E1/T1 over Fiber

The FRM220-E1/T1 is a fiber media transceiver for G.703 E1/T1 transmissions designed for point-to-point use. The BNC model provides unbalanced 75 Ohm coaxial E1 connections while the RJ-45 model provides switchable balanced 120 Ohm E1 or 100 Ohm T1 connections over twisted pair wiring. When the FRM220-E1/T1 card is placed in the FRM220 rack with in-band management, the card status, type, version, fiber link status, E1 or T1 link status and alarms for both local card and remote unit can all be displayed. When set for E1 mode, the FRM220-E1/T1 also supports fractional (structured) E1 when connected to a remote FRM220-Data, synchronous data communications converter. In an E1 transmission network where end connection requires synchronous data communication such as V.35 or RS-530 (X.21, RS-449), these units eliminate the need for an extra CSU/DSU. When placed in a single slot chassis and used standalone without management, the card may be configured by DIP switches.

Feature

- In-band network Managed via Terminal, web or SNMP in FRM220 chassis
- T1/E1 RJ-45 (USOC RJ-48C) or E1 Coax (BNC) to Fiber converter
- Supports AMI or B8ZS/HDB3 line codes
- T1 supports unframed to FRM220-Data
- E1 supports unframed or fractional (N x 64k) to FRM220-Data
- User selectable E1 or T1 setting
- Electrical and optical Loop back tests
- Standalone RS232 console management via CH01M

Specifications

Optical Interface	Connector	1x9 (SC, ST, FC)
	Data rate	36.864Mbps
	Line coding	Scrambled NRZ
	Bit Error Rate	Less than 10 ⁻¹⁰
	Distance	MM 2km, SM 15/30/50km WDM 20/40km
	Wavelength	1310nm, 1550nm
Electrical Interface	Connector	RJ45 E1-120Ω, T1-100 Ω, BNC E1-75 Ω
	Data rate	E1: 2.048Mbps, T1:1.544Mbps
	Line Code	E1 HDB3/AMI, T1: B8ZS/AMI
	Cable type	Cat.3 or higher Twisted-Pair cable
Standards	E1	ITU-T G.703, G.704, G.706, G.732, G.823
	T1	ITU-T G.703, G.704, AT&T, TR-62411, ANSI T1.403

Indications	Power, FX-Link, E1/T1 SIG, Test, SYN, RD, TD, AIS (E1/T1R) Power, FX-Link, E1 SIG, Test(E1B)
Power Input	12VDC
Power Consumption	< 6W
Dimensions	Card: 155 x 20.8 x 88mm (D x W x H)
Weight	120g
Temperature	0 ~ 50°C (Operating), -10 ~ 70°C (Storage)
Humidity	10 ~ 90% non-condensing
Certification	CE, FCC
MTBF	65,000 hrs

Application

In-band Managed PDH Fiber Modem

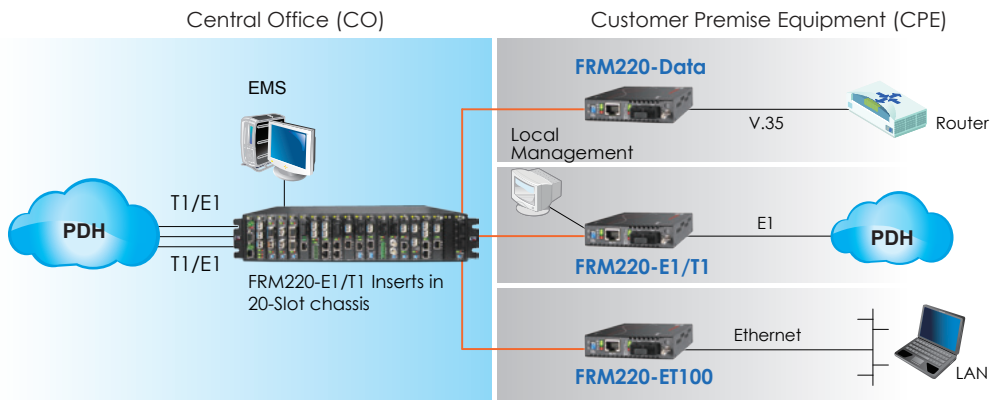

Ordering Information

Model Name	Description
FRM220-E1/T1R	E1/T1 RJ-45 fiber modem
FRM220-E1B	E1 BNC fiber modem
FRM220-E1/T1R-SFP	E1/T1 RJ-45 fiber modem (SFP module not included)
FRM220-E1B-SFP	E1 BNC fiber modem (SFP module not included)
Connector Type	Connectivity Distance

SC,ST,FC 002: 2km 015: 15km 030: 30km 050: 50km
 (Not Applicable for SFP Type) 20A: WDM 20km A type 20B: WDM 20km B type 40A: WDM 40km A type 40B: WDM 40km B type

Connector Type Connectivity Distance
FRM220 - □□ / □□□ - □□□□
 Example: FRM220 - E1/T1R - SC002

Note: This card may be set by DIP switch and placed in CH01 chassis, or set by serial console if placed in CH01M chassis. When connected as a remote to a managed central chassis, this card supports in-band management and only needs a CH01 chassis.



FRM220-DATA

RS232/530/V35 over Fiber

The FRM220-DATA is a fiber modem for high-speed (up to 8.192Mbps) synchronous or low speed synchronous and asynchronous data transmissions (V.35, RS-232, RS-530, X.21 or RS-449) over fiber optical media. When the FRM220-DATA card is placed in the FRM220 rack with SNMP management, in-band management allows viewing the card and remote converter's status, type, version, fiber link status, data link status and alarms. Both card and remote can be configured to enable or disable the port, reset the port, set the data rate, modify the clock mode, and initiate local or far end loop back tests. The FRM220-Data fiber modem may also be paired with the FRM220-E1/T1 for Nx64K transmissions. When placed in a single slot chassis and used standalone without management, the card may be configured by DIP switches.

Feature

- Synchronous or Asynchronous data over fiber
- In-band network management via terminal, web or SNMP in FRM220 chassis
- Software selectable interface, V.35, X.21, RS-530, RS-449, RS-232 (sync mode)
- Software selectable DCE or DTE mode
- User selectable data rate n x 64kbps, up to 9Mbps
- Independent clock mode setting, (internal, external, or recovery) for transmit and receive
- Electrical and optical loop back tests
- Compatible with FRM220-E1 on same fiber link for N x 64k
- Standalone RS232 console management via CH01M

Specifications

Optical Interface	Connector	SFP LC
	Data rate	36.864Mbps
	Line coding	Scrambled NRZ
	Bit Error Rate	Less than 10-10
	Distance	MM 2km, SM 15/30km, WDM 20/40km
	Wavelength	1310nm, 1550nm
Dimensions	Card: 155 x 20.8 x 88mm (D x W x H)	
Weight	130g	
Temperature	0 ~ 50°C (Operating), -10 ~ 70°C (Storage)	
Humidity	10 ~ 90% non-condensing	
Certification	CE, FCC	
MTBF	65,000 hrs	

Electrical Interface	Connector	HDB26F w/ adapter cable for V35
		X21, RS530, RS449,RS232
	Line Code	NRZ
	Baud Rate	RS-232 up to 384K async V.35/RS-530 up to 9152k sync where n=1 to 143 (64K ~ 9152Kkbps)
	Clock source	Internal, Recovery, External
	Standard	ITU-T
Indications	LED (Power, FX Link, RTS, Test , TD, RD, CTS, DCD)	
Power Input	12VDC	
Power Consumption	< 6W	

Application

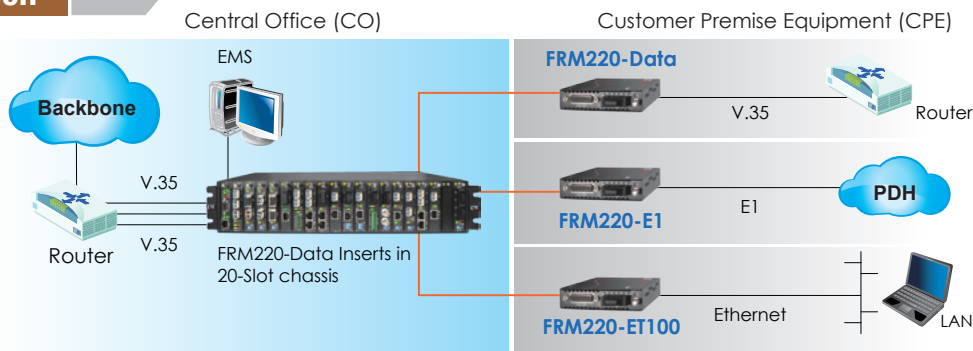

Ordering Information

Model Name	Description
FRM220-V35	V.35 to fiber with V35 cable
FRM220-X21	X.21 to fiber with X.21 cable
FRM220-RS530	RS530 to fiber with RS530 cable
FRM220-RS449	RS449 to fiber with RS449 cable
FRM220-RS232	RS232 to fiber with RS232 cable
FRM220-V35-SFP	V.35 to fiber with V35 cable (SFP module not included)
FRM220-X21-SFP	X.21 to fiber with X.21 cable (SFP module not included)
FRM220-RS530-SFP	RS530 to fiber with RS530 cable (SFP module not included)
FRM220-RS449-SFP	RS449 to fiber with RS449 cable (SFP module not included)
FRM220-RS232-SFP	RS232 to fiber with RS232 cable (SFP module not included)
Connector Type	Connectivity Distance
SC,ST,FC	002: 2km 015: 15km 030: 30km
(Not Applicable for SFP Type)	20A: WDM 20km A type 20B: WDM 20km B type 40A: WDM 40km A type 40B: WDM 40km B type

Note: This card may be set by DIP switch and placed in CH01 chassis, or set by serial console if placed in CH01M chassis. When connected as a remote to a managed central chassis, this card supports in-band management and only needs a CH01 chassis.

Interface Type Connector Type Connectivity Distance
FRM220 - □□□□ - □□□□□□
 Example: **FRM220 - V35 - SC002**



FRM220-ET100

10/100Base-TX Ethernet over E1 Fiber

FRM220-ET100 is a single Port Fiber WAN (TDM) card with built-in HDLC Ethernet Bridge for the FRM220 Series. The converter supports Nx 64 data rates from 64Kbps up to 2.048Mbps when linked by fiber to FRM220-Data or FRM220-E1/ T1 cards. The clock source may be selected internally or recovered from received fiber signal. The Ethernet port utilizes a single RJ-45 connector. When the FRM220-ET100 card is placed in the FRM220 rack with SNMP management, the management can view the converter card's status, type, version, Ethernet link status and alarms. The card can be configured to enable or disable the port, reset the card, set clocking, data rate and provide digital diagnostic loopbacks. A unique feature of the FRM220-ET100 is the use of a common card design which may either be inserted in the FRM220-CH01 single slot chassis as a stand-alone modem or as a card when placed in the FRM220-CH20 managed rack.

Feature

- 1-Port Ethernet to HDLC (fiber) converter
- P2P Fiber link compatible with FRM220-E1/T1 and FRM220-Data
- Clock source (internal or external)
- Nx64k data rate (64kbps~2048kbps)
- Ethernet encapsulated with ISO 13239 standard HDLC
- Loop Back with integral BERT & LED indicators
- Firmware upgradeable, when placed in managed FRM220 chassis
- Interface connectors, RJ-45 for 10/100 Base-Tx
- Fixed optical for SC or ST, 2km(MM) to 120km(SM)

Specifications

TDM (fiber) Interface	Connector	1 x 9 (SC, ST, FC)	Indications	PWR, TD/RD Act, Test, Sys, Alarm, Error	
	Data rate	64~2048kb/s(nx64)		Power Input	12VDC
	Distance	MM 2km, SM 15/30/50km WDM 20/40km			Power Consumption
	Wavelength	MM 1310nm, SM 1310, 1550nm WDM 1310Tx/1550Rx (type A) 1550Tx/1310Rx (type B)		Dimensions	
Ethernet Interface	Standards	IEEE 802.3u, IEEE 802.3	Weight	130g	
	Data rate	10Mbps, 100Mbps	Temperature	0 ~ 50°C (Operating), -10 ~ 70°C (Storage)	
	Duplex mode	Half / Full duplex	Humidity	10 ~ 90% RH (non-condensing)	
	Connector	RJ-45	Certifications	CE, FCC	
Tests	E1 Loops	Remote Loop back	MTBF	75,000 hrs	

Application

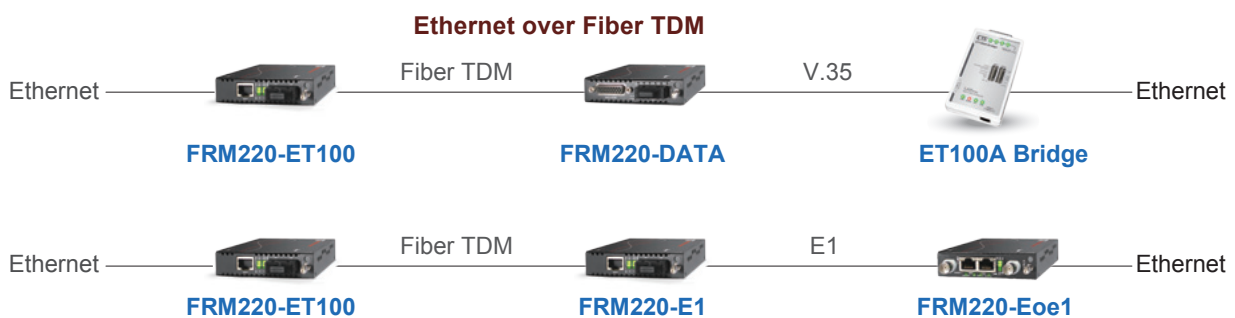

Ordering Information

Model Name	Description
FRM220-ET100	10/100Base-TX to E1 fiber modem
Connector Type	Connectivity Distance
SC,ST,FC	002: 2km 015: 15km 030: 30km 050: 50km 20A: WDM 20km A type 20B: WDM 20km B type 40A: WDM 40km A type 40B: WDM 40km B type

Connector Type Connectivity Distance

FRM220 - ET100 -

Example: **FRM220 - ET100 - SC002**

Note: This card may be set by DIP switch and placed in CH01 chassis, or set by serial console if placed in CH01M chassis. When connected as a remote to a managed central chassis, this card supports in-band management and only needs a CH01 chassis.



PHB-200M PHB-200

20x 100/1000Base-T to
20x100/1000Base-X SFP Patching Hub

3

SFP Patching Hub

PHB-200M is a 20-channel Managed SFP patching hub that converts Ethernet copper 100/1000Base-TX to SFPs working at 100Mbps and 1000Mbps. PHB-200M can connect to any RJ-45 Ethernet switch and supports any third-party standard SFP module from any SFP vendor. PHB-200M can also be used as an Ethernet copper-to-fiber media converter. With different kinds of fiber optic media, both multi-mode and single mode fiber are available as well as BiDi which allows bi-directional transmissions using only a single fiber to extend the distance of Fast Ethernet and Gigabit Ethernet networks. With SNMP and Web-based management, the network administrator can monitor, configure and control the activity of PHB-200M remotely.

Feature

- 1U" Height 19" 20 channels Managed SFP patching hub
- 20-port 100/1000Base-T to 20-port 100/1000Base-X SFP
- Auto MDI/MDIX in TP port
- Auto-Negotiation in TX port
- Supports hot-swappable SFPs working at 100 Mbps and 1000 Mbps
- Supports Web, Telnet, SNMP Management (PHB-200M)
- Local configuration via DB9 port
- Supports Link Pass-Through & Link loss Alarm
- Supports any third-party standard SFP module
- Supports SFP DDM I
- Layer 1 wire-speed conversion with fully transparent function
- Available in 3 types : power built-in AC, DC, AC+DC

Specifications

Optical Interface	Connector	SFP LC	Electrical Interface	Connector	RJ-45
	Number of port	20		Number of port	20
	Data rate	100/1000Mbps		Data rate	10/100/1000Mbps
	Duplex mode	Full duplex		Duplex mode	Half / Full duplex
	Fiber	MM 50/125um, 6.25/125um, SM 9/125um		Cable	10Base-T Cat. 3, 4, 5 UTP 100/1000Base-T Cat.5, 5e or higher
	Distance	MM 2km, SM 15/30/50/80/120km, WDM 20/40/60/80km		Power	100 ~ 240VAC, 36~60 VDC
Wavelength	1310nm, 1550nm, CWDM 1471nm ~ 1611nm	Power Consumption	65W		
Management	Console, Web, Telnet, SNMP		Dimensions	180 x 440 x 44mm (D x W x H)	
Control Port	RS-232 DCE, DB-9, female		Weight	3.4kg	
Standards	IEEE 802.3, 802.3u, 802.3ab, 802.3z, 802.3x		Temperature	0 ~ 50°C (Operating), -10 ~ 70°C (Storage)	
Indications	Power FX-Link, Duplex, TX-Link/Act, TX-Speed		Certification	CE, FCC	

Application

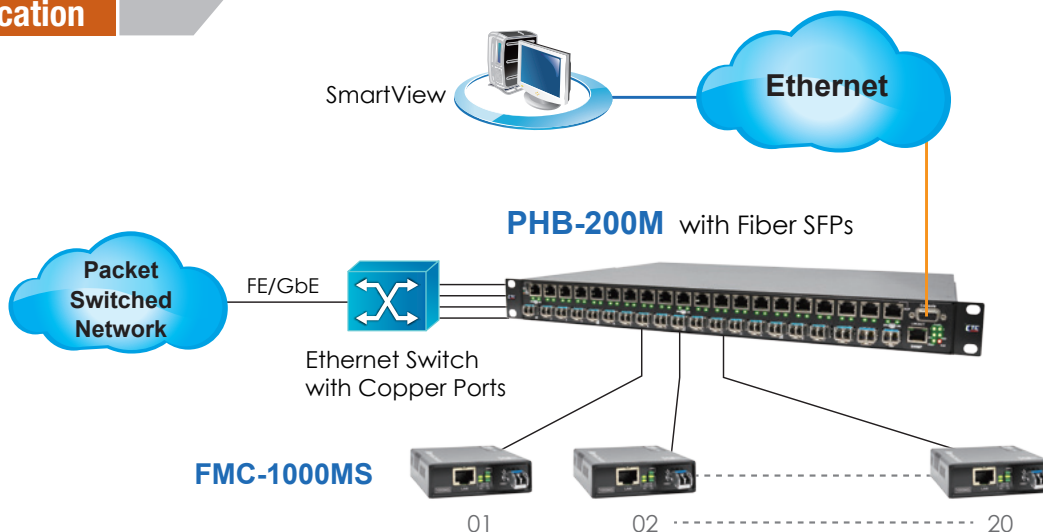

Ordering Information

Model Name	Description
PHB-200M-AC, DC, AD	Managed 20-port 100/1000-TX to 20-port 100/1000-X SFP, built-in AC, DC or AD (AC+DC) Power
PHB-200-AC, DC, AD	20-port 100/1000-TX to 20-port 100/1000-X SFP, built-in AC, DC or AD (AC+DC) Power

Power Type
PHB-200 -
 Example: PHB-200M - DC



FMC-CH17

Simple Converter Chassis

The FMC-CH17 is a 2U high 19" 17 slots chassis. The chassis provides an economic solution in low density fiber converter installations where no management features are required. Each FMC or VDTU2A-301 converter is an independent Ethernet to fiber or Ethernet to copper media converter that may be used as a stand-alone converter or placed in the FMC-CH17 chassis. With two power supplies, the FMC-CH17 chassis supports redundant power from any of two power options. The AC supplies operate from (100-240VAC) and DC supplies operate from 36-60VDC. The built in cooling fan ensures that the temperatures in the rack remain within the tolerated working range.

Feature

- FMC-CH17, 2U, 19", 17-Slot chassis with single or dual built-in power for AC or DC
- Cross flow cooling fan built-in.
- Designed for 19" Rack mounting
- FMC units are hot swappable

Specifications

Power Input	AC : 100 ~240V or DC : 36 ~ 60V
Power Consumption	<60W
Dimensions (D x W x H)	199 x 476 x 88 mm
Weight	7.9Kg

Temperature	0 ~ 50°C (Operating), -10 ~ 70°C (Storage)
Humidity	10 ~ 90% non-condensing
Certification	CE, FCC
MTBF	65,000 hrs

Application



FMC-CH17 Front view

- FMC Option Converters
- Fast Ethernet
 - Gigabit Ethernet
 - VDSL2 LAN Extender

17-Slot



FMC-CH17 Back view



Ordering Information

Model Name	Description
FMC-CH17-AC, DC, AD, AA, DD	2U, 19", 17-Slot FMC Converter Chassis with AC, DC, AD, AA or DD power

Power Type
FMC - CH17 -
 Example: FMC - CH17 - DC



FMC-1000S

10/100/1000Base-T to 1000Base-X SFP Media Converter

The FMC-1000S family are Gigabit Ethernet 10/100/1000Base-T to 1000Base-X non-managed stand-alone media converters, which give you the fiber cabling connectors, LC with SFP module. Pluggable SFP are available in both multi-mode and single mode types as well as BiDi which allows bi-directional transmissions using only a single fiber cable. Auto-negotiation will automatically tailor to convert full-duplex signals, according to IEEE802.3u standards. LED indicators signal the power status of the converter, UTP port speed and Link status FX port speed and Link status.

Feature

- 10/100/1000Base-T to 1000Base-X Converter
- Auto-Negotiation
- Auto MDI/MDIX
- Forward 2048 bytes (Max.) packets
- Supports Q in Q double tagged frame transparent
- Supports IEEE 802.1Q Tag VLAN pass thru
- Concentrated into FMC-CH17 chassis (FMC-1000S Adapter type only)

Specifications

Optical Interface	Connector	SFP LC	Standards	IEEE 802.3, 802.3u, 802.3Z, 802.3ab		
	Data rate	1.25G		Indications	LED (Power, FX Link, FX SPD, TX SPD, TX Link)	
	Duplex mode	Full duplex			Power Input	Adapter Type: DC 12V
	Fiber	MM 50/125µm, 62.5/125µm SM 9/125µm				Power Built-in Type : AC 100 ~ 240V
	Distance	MM 2km, SM 15/30km WDM 20/40km				Power Built-in Type: DC 18 ~ 60V
	Wavelength	MM 1310nm, SM 1310,1550nm WDM 1310Tx/1550Rx (Type A) 1550Tx/1310Rx (Type B)				Power Consumption
Electrical Interface	Connector	RJ-45	Dimensions (D x W x H)			
	Data rate	10Mbps, 100Mbps, 1000Mbps		Power Built-in Type : 135 x 23 x 73.4mm		
	Duplex mode	Full duplex		Weight	Adapter Type : 120g	
	Cable	100Base-TX Cat.5, 5e or higher 1000Base-T Cat.5, 5e or higher			Power Built-in Type : 140g	
	Temperature					
		Humidity				
Certification						CE, FCC
			MTBF			

Application

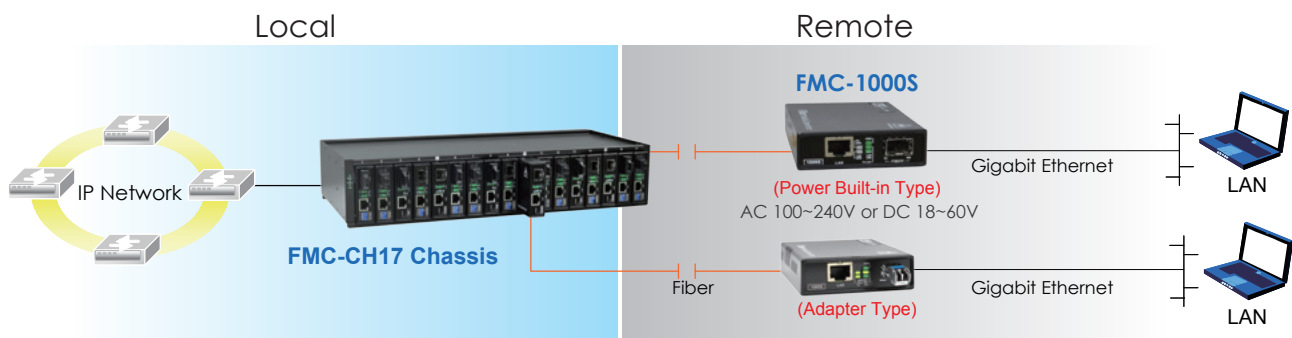

Ordering Information

Model Name	Description
FMC-1000S	10/100/1000Base-T to 1000Base-X SFP Non-managed Media Converter Adapter Type
FMC-1000S-AC,DC	10/100/1000Base-T to 1000Base-X SFP Non-managed Media Converter with AC or DC Power Built-in Type

Power Type
FMC - 1000S - □□
 Example: FMC - 1000S - DC



FMC-10/100

10/100Base-TX to 100Base-FX Media Converter

The FMC-10/100 family are Fast Ethernet 10/100Base-TX to 100Base-FX non-managed stand-alone media converters, which give you the options to choose from the most popular fiber cabling connectors, ST, SC or FC. Both multi-mode and single mode converter models are available as well as BiDi which allows bi-directional transmissions using only a single fiber cable. Auto-negotiation will automatically tailor to convert both half-duplex and full-duplex signals, according to IEEE802.3u standards. LED indicators signal the power status of the converter, UTP port speed, Link, and duplex status, FX port Link and duplex status.

Feature

- 10/100Base-TX to 100Base-FX Converter
- Auto-Negotiation or forced mode
- Auto MDI/MDIX
- Forward 1600 bytes (Max.) packets
- Supports flow control (Pause)
- Supports Link Fault Pass-Through (LFPT)
- Supports Far End Fault Indication (FEFI)
- Forward 9K jumbo packets in converter mode (100M/Full)
- Concentrated into FMC-CH17 chassis (FMC-10/100 Adapter type only)

Specifications

Optical Interface	Connector	1x9 (SC, ST, FC)	Standards	IEEE 802.3, IEEE 802.3u		
	Data rate	125Mbps		Indications	LED (Power, FX Link, TX SPD, TX Link, TX Duplex, FEF)	
	Duplex mode	Full duplex			Power Input	Adapter Type: DC 12V
	Fiber	MM 50/125µm, 62.5/125µm SM 9/125µm		Power Built-in Type: AC 100 ~ 240V		
	Distance	MM 2km, SM 15/30km WDM 20/40km		Power Built-in Type: DC 18 ~ 60V	Power Consumption	< 3W
	Wavelength	MM 1310nm, SM 1310, 1550nm WDM 1310Tx/1550Rx (Type A) 1550Tx/1310Rx (Type B)		Dimensions (D x W x H)		Adapter Type: 108 x 23 x 73.4mm
Electrical Interface	Connector	RJ-45	Power Built-in Type: 135 x 23 x 73.4mm			
	Data rate	10Mbps, 100Mbps	Weight	Adapter Type: 120g		
	Duplex mode	Half / Full duplex		Power Built-in Type: 140g		
	Cable	10Base-T Cat.3, 4, 5, cat.6	Temperature	0 ~ 50°C (Operating), -10 ~ 70°C (Storage)		
		100Base-TX Cat.5, 5e or cat.6		Humidity	10 ~ 90% non-condensing	
Certification			CE, FCC			
	MTBF			65,000 hrs		

Application

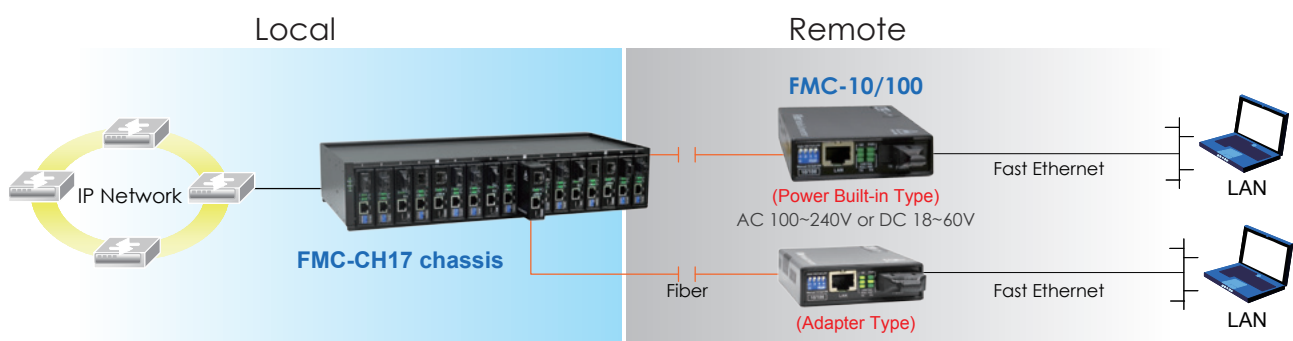

Ordering Information

Model Name	Description
FMC-10/100	10/100Base-TX to 100Base-FX Non-Managed Media Converter Adapter Type
FMC-10/100-AC	10/100Base-TX to 100Base-FX Non-Managed Media Converter with AC Power
FMC-10/100-DC	10/100Base-TX to 100Base-FX Non-Managed Media Converter with DC Power
Connector Type	Connectivity Distance
SC, ST, FC	002: 2km 015: 15km 030: 30km 20A: WDM 20km A type 20B: WDM 20km B type 40A: WDM 40km A type 40B: WDM 40km B type 80A: WDM 80km A type 80B: WDM 80km B type 120A: WDM 120km A type 120B: WDM 120km B type

Power Type
FMC - 10/100 - □□
 Example: FMC - 10/100 - AC



FMC-1000M

10/100/1000Base-T to 1000Base-X Web Smart OAM Managed Converter

The FMC-1000M family are Gigabit Ethernet 10/100/1000Base-T to 1000Base-X Web Smart OAM/IP based managed fiber media converters, which provide simple control and setting function on each Ethernet port through out of band network via a Web browser. The FMC-1000M media converters give you the fiber cabling connector, Both multi-mode and single mode converter models are available as well as BiDi which allows bi-directional transmissions using only a single fiber cable. Auto-negotiation will automatically tailor to convert both half-duplex and full-duplex signals, according to IEEE802.3u standards. LED indicators signal the power status of the converter, UTP port speed, Link, and duplex status, FX port Link and duplex status.

Feature

- 10/100/1000Base-T to 1000Base-X Converter
- Auto-Cross over for MDI/MDIX in TP port
- Auto-Negotiation or Manual mode in TP port
- Supports flow control Enable or Disable
- Web management on stand-alone.
- Supports 802.3ah-OAM/IP in-band management
- Supports Jumbo Frame 9K Packet, Ingress/Egress Bandwidth control
- Supports Link Fault Pass Through (LFP) and Auto Laser Shutdown (ALS)
- Firmware upgrade via Web, Dying gasp (remote power failure detection)

FMC-1000M-AD

- Metal Chassis
- Power built-in type: AC + DC
- Dimension: 201 x 35 x 135mm (DxWxH)



Specifications

Optical Interface	Connector	1x9 (SC)	Indications	LED (Power, FX-Link, FX Speed, LAN Speed, LAN Link)	
	Data rate	1000Mbps		Power Input	Adapter Type: DC 12V
	Duplex mode	Full duplex			Power Built-in Type : AC 100 ~ 240V, DC 18 ~ 60V
	Fiber	MM 50/125µm, 62.5/125µm SM 9/125µm		Power Consumption	< 4W
	Distance	MM 550m, SM 20/40km WDM 20/40km			Dimensions (D x W x H)
	Wavelength	MM 1310nm, SM 1310, 1550nm WDM 1310Tx/1550Rx (Type A) 1550Tx/1310Rx (Type B)		Power Built-in Type : 135 x 23 x 73.4mm (FMC-1000M-AC or DC)-Plastic	
Electrical Interface	Connector	RJ-45	201 x 35 x 135mm (FMC-1000M-AD)-Metal		
	Data rate	10Mbps, 100Mbps, 1000Mbps	Weight	Adapter Type : 120g (FMC-1000M)	
	Duplex mode	Half / Full duplex		Power Built-in Type : 140g (FMC-1000M-AC or DC) 1.2kg (FMC-1000M-AD)	
	Cable	10Base-T Cat.3, 4, 5, UTP 100Base-TX Cat.5, 5e or higher	Temperature	0 ~ 50°C (Operating), -10 ~ 70°C (Storage)	
Standards	IEEE 802.3, IEEE 802.3u IEEE 802.3ab, 802.3z	Humidity		10 ~ 90% non-condensing	
	Standards		IEEE 802.3, IEEE 802.3u IEEE 802.3ab, 802.3z	Certification	CE, FCC
Standards		IEEE 802.3, IEEE 802.3u IEEE 802.3ab, 802.3z	MTBF		65,000 hrs

Application

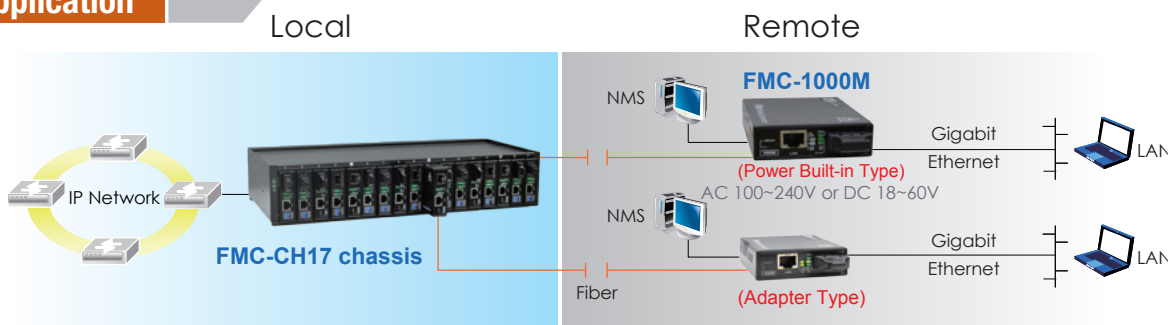

Ordering Information

Model Name	Description
FMC-1000M	10/100/1000Base-T to 1000Base-X Web Smart OAM/IP Managed Media Converter Adapter Type
FMC-1000M-AC,DC	10/100/1000Base-T to 1000Base-X Web Smart OAM/IP Managed Media Converter with AC or DC Power
FMC-1000M-AD	10/100/1000Base-T to 1000Base-X Web Smart OAM/IP Managed Media Converter with AC + DC Power
Connector Type	Connectivity Distance
SC	001: 550m 002: 2km S/M 010: 10km 020: 20km 040: 40km 20A: WDM 20km A type 20B: WDM 20km B type 40A: WDM 40km A type 40B: WDM 40km B type

Power Type
FMC - 1000M - □□
 Example: FMC - 1000M - DC



FMC-1000MS

10/100/1000Base-T to 100/1000Base-X SFP Web Smart OAM Managed Converter

The FMC-1000MS family are Gigabit Ethernet 10/100/1000Base-T to 100/1000Base-X Web Smart OAM/IP managed fiber media converters, which provide simple control and setting function on each Ethernet port through out of band network via a Web browser. The FMC-1000MS media converters give you the fiber cabling connector, SFP-LC Both multi-mode and single mode converter models are available as well as BiDi which allows bi-directional transmissions using only a single fiber cable. Auto-negotiation will automatically tailor to convert both half-duplex and full-duplex signals, according to IEEE802.3u standards. LED indicators signal the power status of the converter, UTP port speed, Link, and duplex status, FX port Link and duplex status.

Feature

- 10/100/1000Base-T to 100/1000Base-X Converter
- Auto-Cross over for MDI/MDIX in TP port
- Auto-Negotiation or Manual mode in TP port
- Supports flow control Enable or Disable
- Supports Jumbo Frame 9K Packet
- Ingress/Egress Bandwidth control
- Supports IEEE802.3ah OAM management
- Firmware upgrade via Web
- Digital Diagnostic (DOM) SFP Support
- Management Password Setting
- Dying gasp (remote power failure detection)
- Supports Link Fault Pass-Through (LFPT) Function
- Supports Auto Laser Shutdown (ALS) Function
- Web management on stand-alone.
- Supports D/D function for SFP fiber transceiver
- Supports On-Line F/W upgrade (local) by the Web manager
- Supports 16 Tag VLAN Group
- RMON counters

Specifications

Optical Interface	Connector	SFP LC
	Data rate	125/1250Mbps
	Duplex mode	Full duplex
	Fiber	MM 50/125µm, 62.5/125µm SM 9/125µm
	Distance	MM 2km, SM 15/30km WDM 20/40km
	Wavelength	MM 1310nm, SM 1310,1550nm WDM 1310Tx/1550Rx (Type A) 1550Tx/1310Rx (Type B)
Electrical Interface	Connector	RJ-45
	Data rate	10Mbps, 100Mbps, 1000Mbps
	Duplex mode	Half / Full duplex
	Cable	10Base-T Cat.3, 4, 5, UTP 100Base-TX Cat.5, 5e or higher

Standards	IEEE 802.3, IEEE 802.3u IEEE 802.3ab, 802.3z
Indications	LED (Power, FX-Link, LAN Speed, LAN Link)
Power Input	Adapter Type: DC 12V
	Power Built-in Type : AC 100 ~ 240V
	Power Built-in Type : DC 18 ~ 60V
Power Consumption	< 3W
Dimensions (D x W x H)	Adapter Type : 108 x 23 x 73.4mm
	Power Built-in Type : 135 x 23 x 73.4mm
Weight	Adapter Type : 120g
	Power Built-in Type : 140g
Temperature	0 ~ 50°C (Operating), -10 ~ 70°C (Storage)
Humidity	10 ~ 90% non-condensing
Certification	CE, FCC
MTBF	65,000 hrs

Application

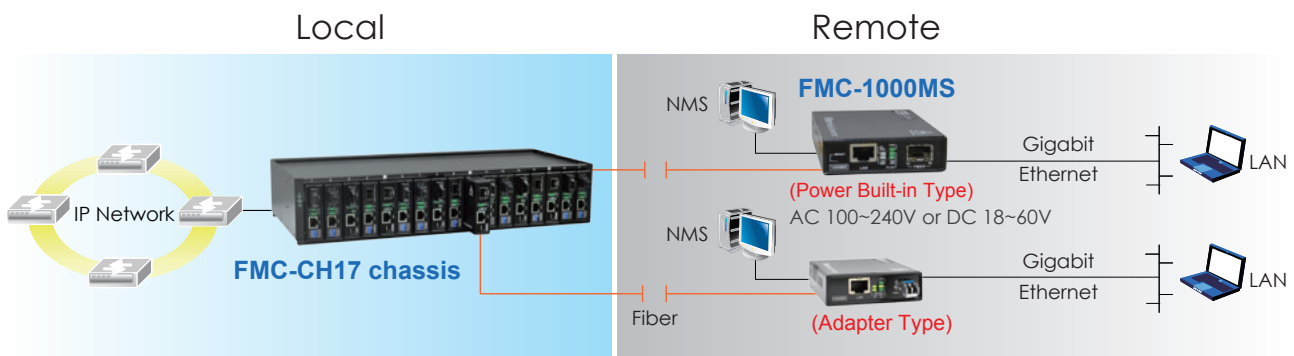

Ordering Information

Model Name	Description
FMC-1000MS	10/100/1000Base-T to 100/1000Base-X SFP Web Smart Managed Media Converter (optional SFP module) Adapter Type
FMC-1000MS-AC,DC	10/100/1000Base-T to 100/1000Base-X SFP Web Smart Managed Media Converter (optional SFP module) with AC or DC Power

Power Type
FMC - 1000MS - □□
 Example: FMC - 1000MS - DC



FMC-10/100i

10/100Base-TX to 100Base-FX In-Band Managed Converter

The FMC-10/100i family are Fast Ethernet 10/100Base-TX to 100Base-FX In-band managed media converters, which give you the options to choose from the most popular fiber cabling connectors, ST, SC or FC. With advanced features like bandwidth control, this media converter is targeted for customer premises equipment in metro LAN, campus, enterprise and FTTx applications. By offering in-band management, this converter can be completely controlled and monitored from a centrally located managed rack controlling all converter settings including band-width control, duplex, and speed configuration. This media converter is completely transparent to Layer 2 and Layer 3 protocols including IEEE 802.1q, VLAN tag, Q in Q, STP, IPX, IP, etc.

Feature

- 10/100Base-TX to 100Base-FX Converter
- Auto-Negotiation or forced mode
- Auto MDI/MDIX
- Forward 2046 bytes (Max.) packets in switch mode
- Forward 9K jumbo packets in converter mode
- Supports Q in Q double tagged frame transparent
- Supports IEEE 802.1q Tag VLAN pass thru
- Supports local / remote In-band management (Monitor and Configure) by the SNMP manager with FRM220-10/100i
- Bandwidth control (Nx32K or Nx512Kbps)
- Supports flow control (Pause)
- Supports remote CPE power fail detect (dying gasp)
- Supports Far End Fault Indication (FEFI)
- Supports Link Fault Pass-Through (LFPT)
- Supports Loop Back Test
- Supports RMON counter
- Auto Laser Shutdown (ALS)
- Fiber Hardware Reset (FHR)
- Online local / remote f/w upgrade

Specifications

Optical Interface	Connector	1x9 (SC, ST, FC)
	Data rate	125Mbps
	Duplex mode	Full duplex
	Fiber	MM 62.2/125µm, 50/125µm. SM 9/125µm
	Distance	MM 2km, SM 15/30km WDM 20/40km
Wavelength	MM	1310nm, SM 1310,1550nm WDM 1310Tx/1550Rx (Type A) 1550Tx/1310Rx (Type B)
	Standards	IEEE 802.3, IEEE 802.3u
Power Input	Adapter Type	DC 12V
	Power Built-in Type	AC 100 ~ 240V
	Power Built-in Type	DC 18 ~ 60V
LEDs	Power, FX Link, TX SPD, TX Link, TX Duplex, FEF	

Electrical Interface	Connector	RJ-45
	Data rate	10Mbps, 100Mbps
	Duplex mode	Half / Full duplex
	Cable	10Base-T Cat.3, 4, 5, UTP 100Base-TX Cat.5, 5e
Distance	100 meters	
Power Consumption	< 3W	
Temperature	0 ~ 50°C (Operating), -10 ~ 70°C (Storage)	
Humidity	10 ~ 90% non-condensing	
Dimensions (D x W x H)	Adapter Type	108 x 23 x 73.4mm
	Power Built-in Type	135 x 23 x 73.4mm
Weight	Adapter Type	120g
	Power Built-in Type	140g
Certification	CE, FCC	
MTBF	65,000 hrs	

Application

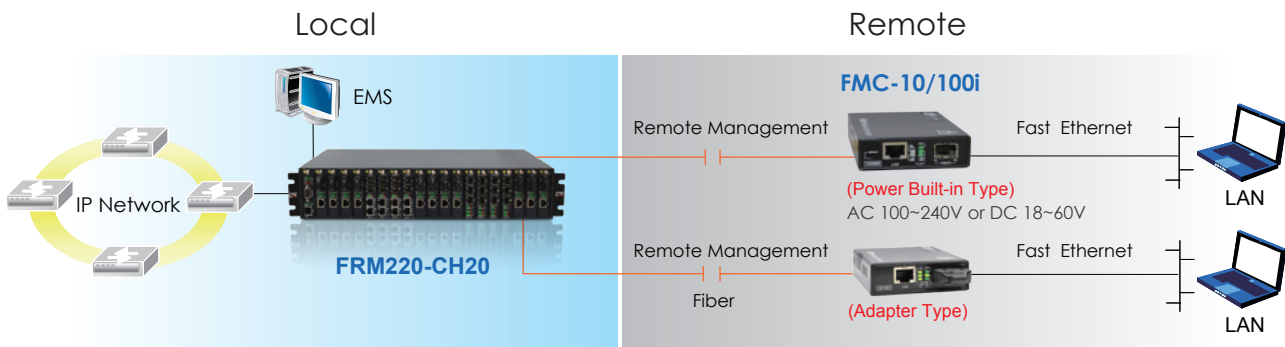

Ordering Information

Model Name	Description
FMC-10/100i	10/100Base-TX to 100Base-FX In-band managed Media Converter Adapter Type
FMC-10/100i-AC,DC	10/100Base-TX to 100Base-FX In-band managed Media Converter with AC or DC Power
Connector Type	Connectivity Distance
SC, ST, FC	002: 2km 015: 15km 030: 30km 20A: WDM 20km A type 20B: WDM 20km B type 40A: WDM 40km A type 40B: WDM 40km B type

Power Type
FMC - 10/100i -
 Example: FMC - 10/100i - DC



Why SyncE & IEEE 1588 v2 ?



With the adoption of 4G LTE/LTE-A by the mobile operators world-wide, mobile backhaul transportation has become one topic of significance as it directly influences the operators mobile service quality. The mobile backhaul is the transport segment that links the cell sites to their mobile switching and control centers. Existing legacy PDH/SDH networks have not been able to fulfill the very high transport speeds of increasing bandwidth requirements. Therefore, most mobile operators are gradually considering adopting all IP network as the architecture of mobile backhaul for 4G LTE/LTE-A.

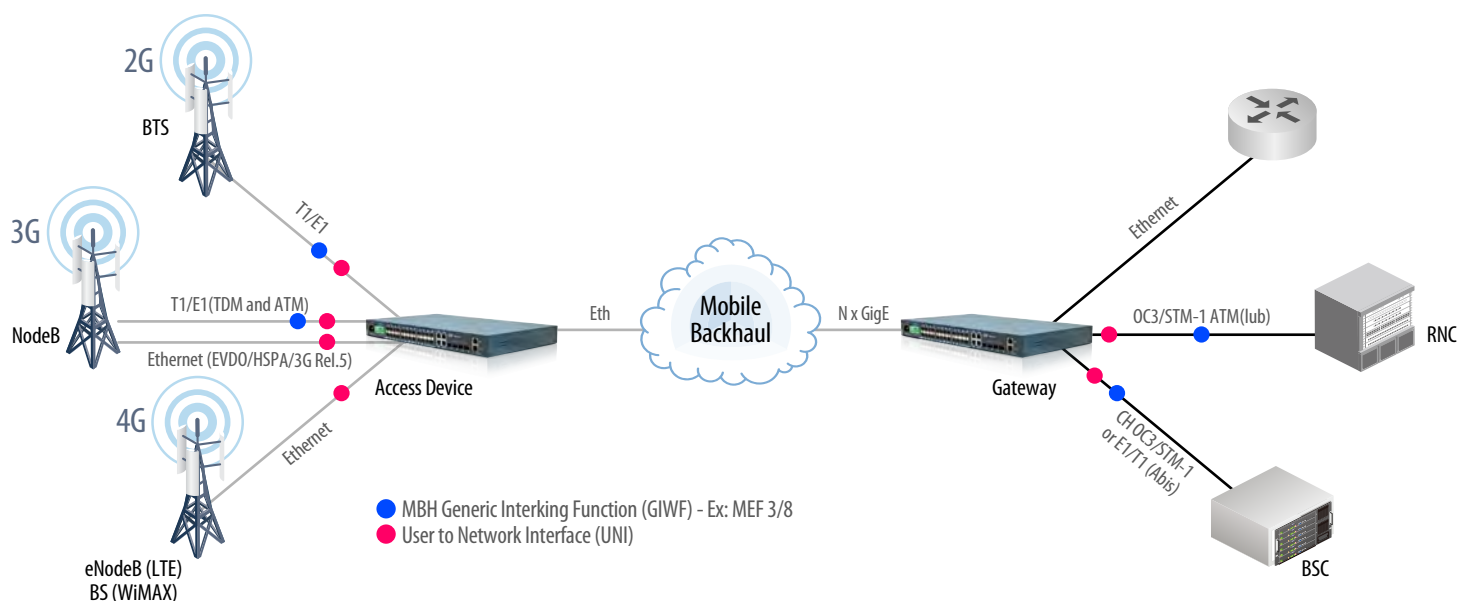

The timing synchronization of the base stations in frequency and time/phase is a very important requirement of mobile communication technology. The following table summarizes why timing synchronization is important.

Application	Why You Need to Comply	Impact of Non-compliance
LTE(FDD)	Call Initiation	Call Interference Dropped calls
LTE(TDD)	Time slot alignment	Packet loss/collisions Spectral efficiency
LTE MBSFN	Proper time alignment of video signal decoding from multiple BTSs	Video broadcast interruption
LTE-A MIMO/COMP	Coordination of signals to/from multiple base stations	Poor signal quality at edge of cells, LBS accuracy
LTE-A eICIC	Interference coordination	Spectral inefficiency & Service degradation

CTC Union offers a solution for access networks and Ethernet demarcation which are fully compliant to MEF proposed mobile backhaul application for 4G LTE services.

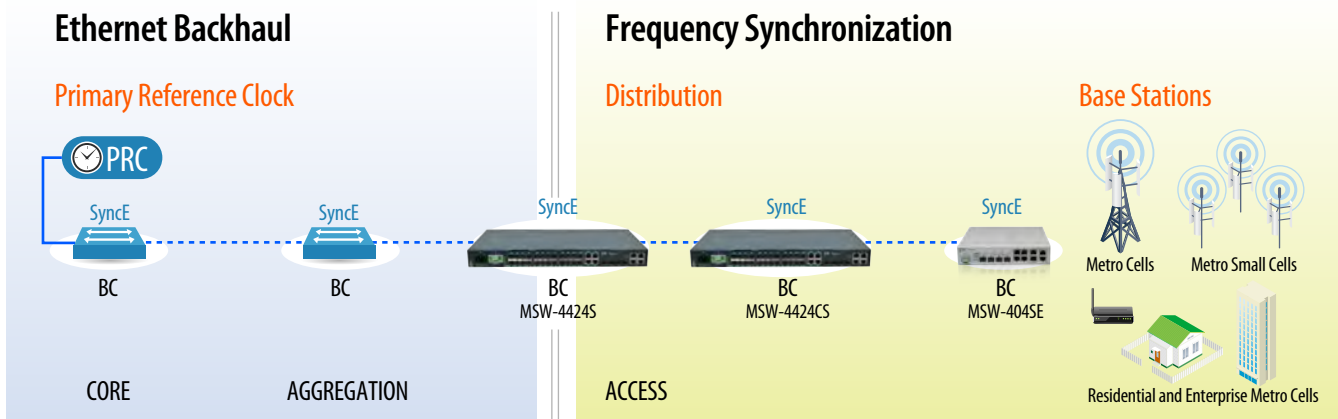

L2+ Gigabit Carrier Ethernet Switch



NEW



MSW-4428X

L2+ Gigabit Carrier Ethernet Switch

The MSW-4428X is positioned as a layer 2+ Gigabit access switch solution. It is equipped with 24 100Base-FX/1000Base-X dual speed SFP slots, 4 ports GbE (10/100/1000Base-T) ports and 4 1000Base-X/10G Base-X dual speed SFP+ uplink slots. The MSW-4428X offers the best flexibility and scalability for the operators or service providers to deploy their Metro Ethernet network. With the deployment of MSW-4428X, operators or service providers can flexibly provision the bandwidth of either 100Mbps or 1000Mbps as well as uplink connection of Gigabit or 10G speed upon their service applications. The MSW-4428X has built-in dual power supplies to enable power redundancy and enhance high network availability.

Aimed at Metro Ethernet applications, the specifications of MSW-4428X fully meet the attributes of Carrier Ethernet proposed by MEF (Metro Ethernet Forum). It complies with CE2.0 standard to support E-Line/E-LAN/E-Tree/E-Access service and enables the bandwidth profile configuration delivering SLA (Service Level Agreement) for end-to-end performance characteristics as well as Ethernet OAM functionality to support carrier grade service OAM management rapidly detecting and recovering from the network incidents in real time.

Feature and Benefits

Fully dual rate architecture of fiber link port

Completely dual speed ports of fiber link to offer the scalable physical connection of Metro Ethernet network for operators

Fully Ethernet OAM enabled

Enabling Ethernet OAM features (IEEE 802.3ah/802.1ag/ITU-T Y.1731) to rapidly detect and recover network fault and save the OPEX for operators as well as increase customer satisfaction

MEF standards compliant solution

CE2.0 compliant product to guarantee the compatibility with other MEF certified equipment and reduce the risk and cost for Metro Ethernet network deployment of operators

Specifications

Interface	100/1000Mbps SFP slots x 24 + 10/100/1000Base-T RJ45 x 4 + 1/10Gbps SFP+ slot x 4
Console Port	RJ-45 console port x 1
Management Port	10/100/1000Base-T RJ45 x 1
Switching fabric capacity	136Gbps
Packet Forwarding capacity	101Mpps
Filter & Forward Rate	14880pps at 10Mbps, 148800pps at 100Mbps, 1488000pps at 1Gbps, 14880000pps at 10Gbps
Transmission Method	Store and Forward Switching
Standard	IEEE 802.3u, IEEE 802.3z, IEEE 802.3ae IEEE 802.1p, IEEE 802.1Q, IEEE 802.1ad, IEEE 802.1d IEEE 802.1w, IEEE 802.1s, IEEE 802.1x, IEEE 802.3ad IEEE 802.3ah, IEEE 802.1ag, ITU-T Y.1731
Packet Buffer	32M bits
Mac Table Size	32K
Max. Packet Size	14K Bytes
VLAN Feature	IEEE 802.1Q tagged VLAN (Max. 4K VLAN groups), port based VLAN MAC based VLAN, protocol based VLAN private VLAN, IEEE 802.1ad Q-in-Q, VLAN translation, GVRP
QoS Feature	IEEE 802.1p 8 priority queues per port, CoS based on switch port; VLAN ID; DSCP; TCP/UDP port IEEE 802.1p priority tag remarking, DSCP remarking, Port based ingress/egress rate limit 3 colors marker-CIR/EIR/Burst bandwidth control
L2 switching Protection	STP, RSTP, MSTP, ITU-T G.8031/G.8032
Trunking	IEEE 802.3ad LACP (Max. 14 trunking group, Max. 8 ports per trunking group)

Security	IEEE 802.1x port based access control MAC based access control authentication RADIUS authentication, limited MAC address learning IP/MAC binding, ACL rule based filtering, TACACS+ IP source guard, DHCP snooping/relay option 82 ARP inspection
IP Multicasting	IGMP throttling, IGMP filtering, IGMP fast leave IGMP snooping v1/v2/v3, MVR, MLD snooping v1/v2
Storm Control Management	Unicast/Broadcast/Multicast storm suppression Web/Telnet CLI/SNMP/console interface Web/CLI authentication, SSH v2, HTTPs, port mirroring syslog, IPv6 management, NTP, SNTP
SNMP agent	SNMP v1/v2c/v3, RMON Group 1,2,3 and 9
Software upgrade	TFTP/HTTP
Ethernet OAM	IEEE 802.3ah/IEEE 802.1ag/ITU-T Y.1731, RFC2544, ITU-T Y.1564
Timing Synchronization	IEEE 1588 V2
MPLS feature	RFC5654 MPLS-TP
LED display	Power, System, Console, Link/Act, Speed
Power input	100V ~ 240V AC, -36 ~ -60V DC
Build in power module combination	AC, DC, AD (AC+DC), AA (AC+AC) or DD (DC+DC)
Power Consumption	< 60W
Operating Temperature	0 ~ 50°C
Humidity	5% ~ 90% (non-condensing)
Dimensions	250x 440x 43.5mm (DxWxH)
Certification	FCC, CE

Application Diagram

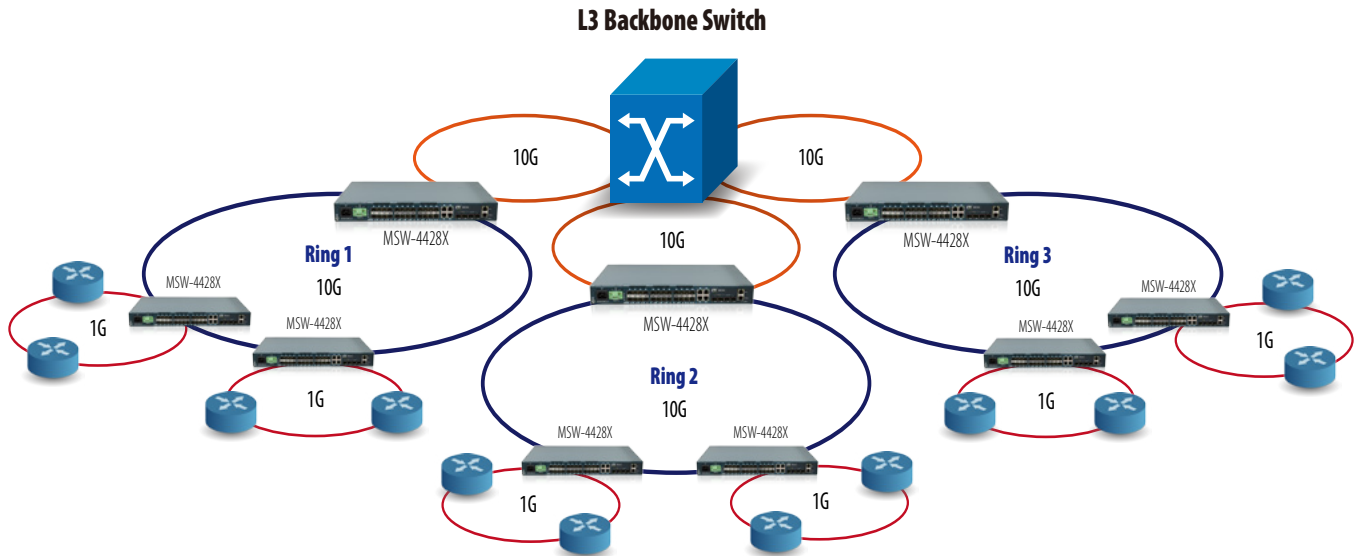

Ordering Information

Model Name	Description
MSW-4428X-AC	L2+ 10G Fiber Access Switch with build-in single AC power module
MSW-4428X-DC	L2+ 10G Fiber Access Switch with build-in single DC power module
MSW-4428X-AA	L2+ 10G Fiber Access Switch with build-in dual AC power module
MSW-4428X-DD	L2+ 10G Fiber Access Switch with build-in dual DC power module
MSW-4428X-AD	L2+ 10G Fiber Access Switch with build-in AC + DC power module

Power Type
MSW-4428X -
 Example: MSW-4428X - AC

Accessories

10G SFP+ Transceiver Module

SFM-1000-SR85	10G SFP+ SR/SW MMF 300m, 850nm VCSEL, 10G Ethernet/FC/SDH/SONET
SFS-1010-LR31	10G SFP+ LR/LW SMF 10km, 1310nm DFB DML, 10G Ethernet/FC/SDH/SONET
SFS-1040-ER55	10G SFP+ ER/EW SMF 40km, 1550nm DFB EML, 10G Ethernet/FC/SDH/SONET
SFS-1080-ZR55	10G SFP+ ZR/EW SMF 80km, 1550nm DFB EML, 10G Ethernet/FC/SDH/SONET

L2+ Gigabit Carrier Ethernet Switch



MSW-4424S

24x GbE, SFP + 4x 10GbE (SFP+) L2+ Carrier Ethernet Switch with SyncE

MSW-4424S layer 2+ managed Gigabit Ethernet switches are positioned as a Carrier Ethernet access switch solution. They are equipped with 24 SFP based 100Base-FX/1000Base-X dual speed optical ports and 4 10G Base-X SFP+ or 1000Base-X SFP uplink ports. The MSW-4424S offers the best flexibility and scalability for operators and service providers to deploy their Metro Ethernet networks. Aimed specifically at Metro Ethernet deployment, the specifications of MSW-4424S fully meet the attributes of Carrier Ethernet proposed by the Metro Ethernet Forum. The switches comply with MEF 9 standard to support E-Line/E-Access services and MEF 14 standard to enable the bandwidth profile configuration for delivering SLA (Service Level Agreement) with predictable end-to-end performance characteristics. MSW-4424S also supports advanced service OAM management. MSW-4424S model supports timing synchronization features (Sync. E and IEEE 1588v2) to enhance and migrate to a carrier grade network for mobile backhaul applications.

Feature and Benefits

Front access and hot swappable design

All of the system modules are front accessible, the hot swappable power and FAN module are designed to keep high network availability without service interruption when components fail

Fully dual rate architecture of fiber link port

Dual speed fiber ports offer scalable physical connections for Metro Ethernet network operators

Fully Ethernet OAM enable

Ethernet OAM features (IEEE 802.3ah/802.1ag/ITU-T.Y.1731) help to rapidly detect and recover network faults and save OPEX for operators as well as increase customer satisfaction

Supports Sync. Ethernet

Advanced synchronization features for carrier Ethernet networks allow operators to deliver services with optimal stability and continuity in the end-to-end connectivity

Specifications

Interface	100/1000Mbps SFP slots x 24 + 1G/10Gbps SFP+ slot x 4
Console Port	RJ-45 console port x 1
1PPS/ToD port	RJ45 x 1
Filter & Forward Rate	14880pps at 10Mbps, 148800pps at 100Mbps, 1488000pps at 1Gbps, 14880000pps at 10Gbps
Switching Capacity	128Gbps
Packet Forwarding Capacity	95Mpps
Transmission Method	Store and Forward Switching
Standard	IEEE 802.3u, IEEE 802.3z, IEEE 802.3ae, IEEE 802.1p IEEE 802.1Q, IEEE 802.1ad, IEEE 802.1D, IEEE 802.1w IEEE 802.1s, IEEE 802.1x, IEEE 802.3ad, IEEE 802.3ah IEEE 802.1ag, ITU-T Y.1731, ITU-T G.8262, IEEE 1588V2
Packet Buffer	32M bits
Mac Table Size	32K
Max. Packet Size	10K Bytes
VLAN Feature	IEEE 802.1Q tagged VLAN (Max. 4K VLAN groups), port based VLAN, MAC based VLAN, protocol based VLAN, private VLAN, IEEE 802.1ad Q-in-Q, VLAN translation, GVRP
QoS Feature	IEEE 802.1p 8 priority queues per port, CoS based on switch port; VLAN ID; DSCP; TCP/UDP port IEEE 802.1p priority tag remarking, DSCP remarking, Port based ingress/egress rate limit 3 colors marker-CIR/EIR/Burst bandwidth control
L2 switching Protection	STP, RSTP, MSTP, ITU-T G.8031/G.8032
Trunking	IEEE 802.3ad LACP (Max. 14 trunking group, Max. 8 ports per trunking group)

Security	IEEE 802.1x port based access control MAC based access control authentication RADIUS authentication, limited MAC address learning IP/MAC binding, ACL rule based filtering, TACACS+ IP source guard, DHCP snooping/relay option 82 ARP inspection
IP Multicasting	IGMP throttling, IGMP filtering, IGMP fast leave IGMP snooping v1/v2/v3, MVR, MLD snooping v1/v2
Storm Control Management	Unicast/Broadcast/Multicast storm suppression Web/Telnet CLI/SNMP/console interface, Web/CLI authentication, SSH v2, HTTPS, port mirroring syslog, IPv6 management, NTP, SNTP
SNMP agent	SNMP v1/v2c/v3, RMON Group 1,2,3 and 9
Software upgrade	TFTP / HTTP
Ethernet OAM	IEEE 802.3ah / IEEE 802.1ag / ITU-T Y.1731
Timing Synchronization	SyncE, IEEE 1588 V2
LED display	Power, System, Console, Link/Act, Speed
Power input	100V ~ 240VAC -30~-60VDC (-48VDC Power) -18 ~ -60VDC (-24VDC Power)
Power Consumption	< 60W
Operating Temperature	-10 ~ 60°C
Humidity	5% ~ 90% (non-condensing)
Dimensions	270.3 x 437.5 x 43.5 mm (D x W x H)
Certification	FCC, CE

Application

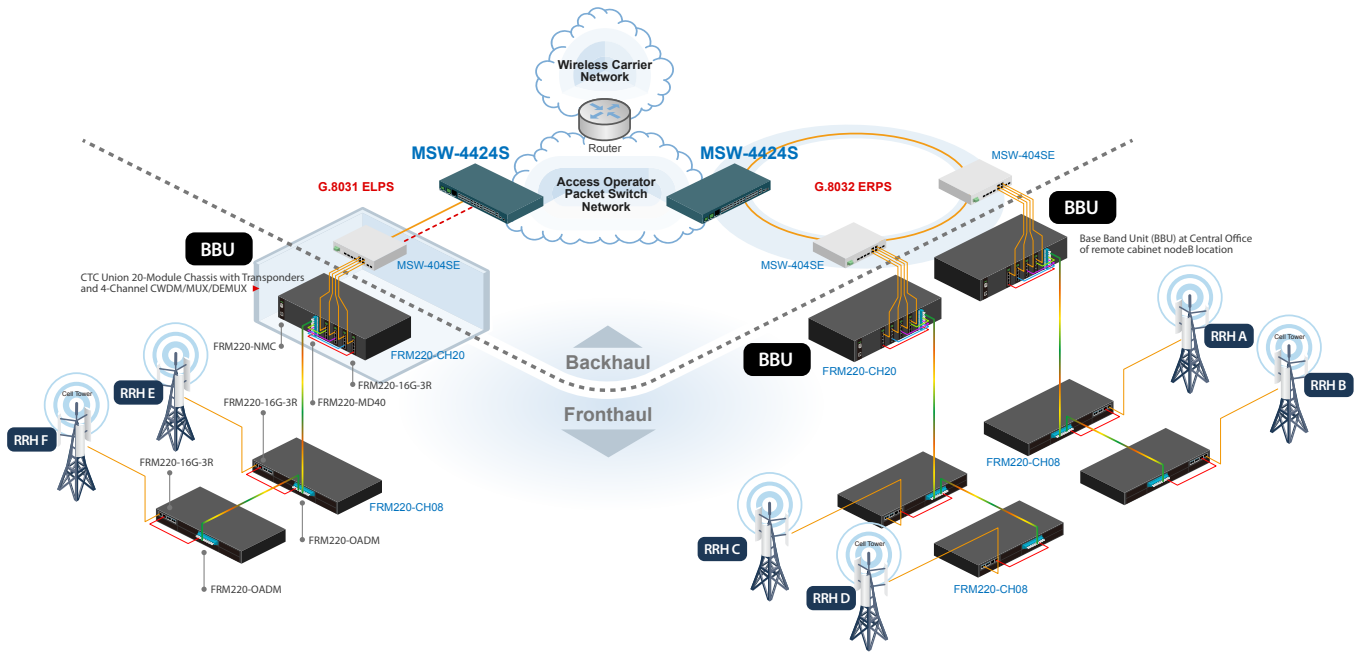

- Carrier Ethernet with multiple class of service
- Traffic Synchronization
- Precisely delivery of time-sensitive service

Ordering Information

Model Name	Description
MSW-4424S-AC	L2+ 10G Fiber Access Switch with SyncE and build-in single AC power module
MSW-4424S-DC	L2+ 10G Fiber Access Switch with SyncE and build-in single DC power module
MSW-4424S-AA	L2+ 10G Fiber Access Switch with SyncE and build-in dual AC power module
MSW-4424S-DD	L2+ 10G Fiber Access Switch with SyncE and build-in dual DC power module
MSW-4424S-AD	L2+ 10G Fiber Access Switch with SyncE and build-in AC + DC power module

Power Type
MSW – 4424S –
 Example: **MSW – 4424S – AC**

Accessories

10G SFP+ Transceiver Module

SFM-1000-SR85	10G SFP+ SR/SW MMF 300m, 850nm VCSEL, 10G Ethernet/FC/SDH/SONET
SFS-1010-LR31	10G SFP+ LR/LW SMF 10km, 1310nm DFB DML, 10G Ethernet/FC/SDH/SONET
SFS-1040-ER55	10G SFP+ ER/EW SMF 40km, 1550nm DFB EML, 10G Ethernet/FC/SDH/SONET
SFS-1080-ZR55	10G SFP+ ZR/EW SMF 80km, 1550nm DFB EML, 10G Ethernet/FC/SDH/SONET

L2+ Gigabit Carrier Ethernet Switch



MSW-4424A

24x GbE, SFP + 4x 10GE (SFP+) L2+ Carrier Ethernet Switch

MSW-4424A layer 2+ managed Gigabit Ethernet switches are positioned as a Carrier Ethernet access switch solution. They are equipped with 24 SFP based 100Base-FX/1000Base-X dual speed optical ports and 4 10G Base-X SFP+ or 1000Base-X SFP uplink ports. The MSW-4424A offers the best flexibility and scalability for operators and service providers to deploy their Metro Ethernet networks. Aimed specifically at Metro Ethernet deployment, the specifications of MSW-4424A fully meet the attributes of Carrier Ethernet proposed by the Metro Ethernet Forum. The switches comply with MEF 9 standard to support E-Line/E-Access services and MEF 14 standard to enable the bandwidth profile configuration for delivering SLA (Service Level Agreement) with predictable end-to-end performance characteristics. MSW-4424A also supports advanced service OAM management to rapidly detect and recover from the network incidents in real time.

Feature and Benefits

Front access and hot swappable design

All of the system modules are front accessible, the hot swappable power and FAN module are designed to keep high network availability without service interruption when components fail

Fully dual rate architecture of fiber link port

Dual speed fiber ports offer scalable physical connections for Metro Ethernet network operators

Fully Ethernet OAM enable

Ethernet OAM features (IEEE 802.3ah/802.1ag/ITU-T.Y.1731) help to rapidly detect and recover network faults and save OPEX for operators as well as increase customer satisfaction

Specifications

Interface	100/1000Mbps SFP slots x 24 + 1G/10Gbps SFP+ slot x 4
Console Port	RJ-45 console port x 1
Filter & Forward Rate	14880pps at 10Mbps, 148800pps at 100Mbps, 1488000pps at 1Gbps, 14880000pps at 10Gbps
Switching Capacity	128Gbps
Packet Forwarding Capacity	95Mpps
Transmission Method	Store and Forward Switching
Standard	IEEE 802.3u, IEEE 802.3z, IEEE 802.3ae, IEEE 802.1p IEEE 802.1Q, IEEE 802.1ad, IEEE 802.1D, IEEE 802.1w IEEE 802.1s, IEEE 802.1x, IEEE 802.3ad, IEEE 802.3ah IEEE 802.1ag, ITU-T Y.1731
Packet Buffer	32M bits
Mac Table Size	32K
Max. Packet Size	10K Bytes
VLAN Feature	IEEE 802.1Q tagged VLAN (Max. 4K VLAN groups), port based VLAN, MAC based VLAN, protocol based VLAN, private VLAN, IEEE 802.1ad Q-in-Q, VLAN translation, GVRP
QoS Feature	IEEE 802.1p 8 priority queues per port, CoS based on switch port; VLAN ID; DSCP; TCP/UDP port, IEEE 802.1p priority tag remarking, DSCP remarking, Port based ingress/egress rate limit 3 colors marker-CIR/EIR/Burst bandwidth control
L2 switching Protection	STP, RSTP, MSTP, ITU-T G.8031/G.8032
Trunking	IEEE 802.3ad LACP (Max. 14 trunking group, Max. 8 ports per trunking group)

Security	IEEE 802.1x port based access control MAC based access control authentication RADIUS authentication, limited MAC address learning IP/MAC binding, ACL rule based filtering, TACACS+ IP source guard, DHCP snooping/relay option 82 ARP inspection
IP Multicasting	IGMP throttling, IGMP filtering, IGMP fast leave IGMP snooping v1/v2/v3, MVR, MLD snooping v1/v2
Storm Control Management	Unicast/Broadcast/Multicast storm suppression Web/Telnet CLI/SNMP/console interface, Web/CLI authentication, SSH v2, HTTPS, port mirroring syslog, IPv6 management, NTP, SNTP
SNMP agent	SNMP v1/v2c/v3, RMON Group 1,2,3 and 9
Software upgrade	TFTP / HTTP
Ethernet OAM	IEEE 802.3ah / IEEE 802.1ag / ITU-T Y.1731
LED display	Power, System, Console, Link/Act, Speed
Power input	100V ~ 240VAC -30~-60VDC (-48VDC Power) -18 ~ -60VDC (-24VDC Power)
Power Consumption	< 60W
Operating Temperature	-10 ~ 60°C
Humidity	5% ~ 90% (non-condensing)
Dimensions	270.3 x 437.5 x 43.5 mm (D x W x H)
Certification	FCC, CE

Application

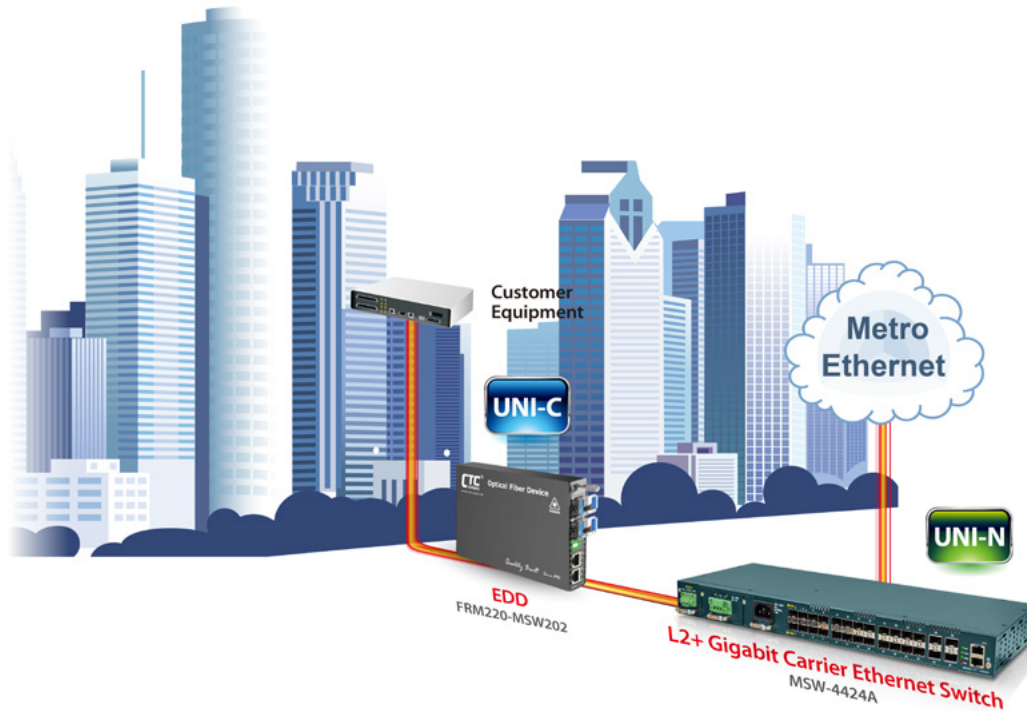

Ordering Information

Model Name	Description
MSW-4424A-AC	L2+ 10G Fiber Access Switch with SyncE and build-in single AC power module
MSW-4424A-DC	L2+ 10G Fiber Access Switch with SyncE and build-in single DC power module
MSW-4424A-AA	L2+ 10G Fiber Access Switch with SyncE and build-in dual AC power module
MSW-4424A-DD	L2+ 10G Fiber Access Switch with SyncE and build-in dual DC power module
MSW-4424A-AD	L2+ 10G Fiber Access Switch with SyncE and build-in AC + DC power module

Power Type
MSW – 4424A –
 Example: MSW – 4424A – AC

Accessories

10G SFP+ Transceiver Module

SFM-1000-SR85	10G SFP+ SR/SW MMF 300m, 850nm VCSEL, 10G Ethernet/FC/SDH/SONET
SFS-1010-LR31	10G SFP+ LR/LW SMF 10km, 1310nm DFB DML, 10G Ethernet/FC/SDH/SONET
SFS-1040-ER55	10G SFP+ ER/EW SMF 40km, 1550nm DFB EML, 10G Ethernet/FC/SDH/SONET
SFS-1080-ZR55	10G SFP+ ZR/EW SMF 80km, 1550nm DFB EML, 10G Ethernet/FC/SDH/SONET

L2+ Gigabit Carrier Ethernet Switch



MSW-4424CS

20x GbE, SFP + 4x GbE Combo + 4x 10GE (SFP+) L2+ Managed Carrier Ethernet Switch with SyncE

The MSW-4424CS is positioned as a layer 2+ Gigabit access switch solution. It is equipped with 20 100Base-FX/1000Base-X dual speed SFP slots, 4 ports GbE combo (10/100/1000Base-T or 100/1000Base-X SFP) ports and 4 1000Base-X/10G Base-X dual speed SFP+ uplink slots. The MSW-4424CS offers the best flexibility and scalability for the operators or service providers to deploy their Metro Ethernet network. With the deployment of MSW-4424CS, the operators or service providers can flexibly provision the bandwidth for either 100Mbps or 1000Mbps as well as uplink connection of Gigabit or 10G speed upon their service applications. The MSW-4424CS has built-in dual power supplies to enable power redundancy function and enhance the high network availability.

Aimed at Metro Ethernet applications, the specifications of MSW-4424CS fully meet the attributes of Carrier Ethernet proposed by MEF (Metro Ethernet Forum). It complies with MEF 9 standard to support E-Line/E-Access service and MEF 14 standard to enable the bandwidth profile configuration delivering SLA (Service Level Agreement) for end-to-end performance characteristics as well as Ethernet OAM functionality to support carrier grade service OAM management rapidly detecting and recovering from the network incidents in real time. MSW-4424CS supports timing synchronization features (SyncE & IEEE 1588v2) to enhance and migrate a carrier grade network for mobile backhaul applications.

Feature and Benefits

Fully dual rate architecture of fiber link port

Completely dual speed ports of fiber link to offer the scalable physical connection of Metro Ethernet network for operators.

Fully Ethernet OAM enabled

Enabling Ethernet OAM features (IEEE 802.3ah/802.1ag/ITU-T Y.1731) to rapidly detect and recover network fault and save the OPEX for operators as well as increase customer satisfaction.

Timing synchronization

Advanced synchronization features such as SyncE or IEEE 1588v2 to allow operators delivering service with optimal stability and continuity in the end-to-end connectivity.

MEF standards compliant solution

CE2.0 compliant product to guarantee the compatibility with other MEF certified equipment and reduce the risk and cost for Metro Ethernet network deployment of operators.

Specifications

Interface	100/1000Mbps SFP slots x 20 + GbE combo port (10/100/1000Base-T or 100/1000Mbps SFP slot) x 4 + 1/10Gbps SFP+ slot x 4	QoS Feature	IEEE 802.1p 8 priority queues per port, CoS based on switch port; VLAN ID; DSCP; TCP/UDP port IEEE 802.1p priority tag remarking, DSCP remarking, Port based ingress/egress rate limit 3 colors marker-CIR/EIR/Burst bandwidth control
Console Port	RJ-45 console port x 1	L2 switching Protection	STP, RSTP, MSTP, ITU-T G.8031/G.8032
1PPS/ToD port	RJ45 x 2	Trunking	IEEE 802.3ad LACP (Max. 14 trunking group, Max. 8 ports per trunking group)
Management Port	10/100/1000Base-T RJ45 x 1	Security	IEEE 802.1x port based access control MAC based access control authentication RADIUS authentication, limited MAC address learning IP/MAC binding, ACL rule based filtering, TACACS+ IP source guard, DHCP snooping/relay option 82 ARP inspection
Filter & Forward Rate	14880pps at 10Mbps, 148800pps at 100Mbps, 1488000pps at 1Gbps, 14880000pps at 10Gbps	IP Multicasting	IGMP throttling, IGMP filtering, IGMP fast leave IGMP snooping v1/v2/v3, MVR, MLD snooping v1/v2
Switching Capacity	128Gbps	Storm Control Management	Unicast/Broadcast/Multicast storm suppression Web/Telnet CLI/SNMP/console interface, Web/CLI authentication, SSH v2, HTTPs, port mirroring syslog, IPv6 management, NTP, SNTP
Packet Forwarding Capacity	95Mpps	SNMP agent	SNMP v1/v2c/v3, RMON Group 1,2,3 and 9
Transmission Method	Store and Forward Switching	Software upgrade	TFTP/HTTP
Standard	IEEE 802.3u, IEEE 802.3z, IEEE 802.3ae, IEEE 802.1p IEEE 802.1Q, IEEE 802.1ad, IEEE 802.1d, IEEE 802.1w IEEE 802.1s, IEEE 802.1x, IEEE 802.3ad, IEEE 802.3ah, IEEE 802.1ag, ITU-T Y.1731, ITU-T G.8262, IEEE 1588 v2	Ethernet OAM	IEEE 802.3ah/IEEE 802.1ag/ITU-T Y.1731
Packet Buffer	32M bits	Timing synchronization	SyncE, IEEE 1588 v2
Mac Table Size	32K	LED display	Power, System, Console, Link/Act, Speed
Max. Packet Size	10K Bytes	Power input	100V ~ 240V AC, -36 ~ -60V DC
VLAN Feature	IEEE 802.1Q tagged VLAN (Max. 4K VLAN groups), port based VLAN, MAC based VLAN, protocol based VLAN private VLAN, IEEE 802.1ad Q-in-Q, VLAN translation, GVRP		

Build in power module combination	AC, DC, AD (AC+DC), AA (AC+AC) or DD (DC+DC)
Power Consumption	< 60W
Operating Temperature	0 ~ 50°C

Humidity	5% ~ 90% (non-condensing)
Dimensions	250x 440x 43.5mm (DxWxH)
Certification	FCC, CE

Application

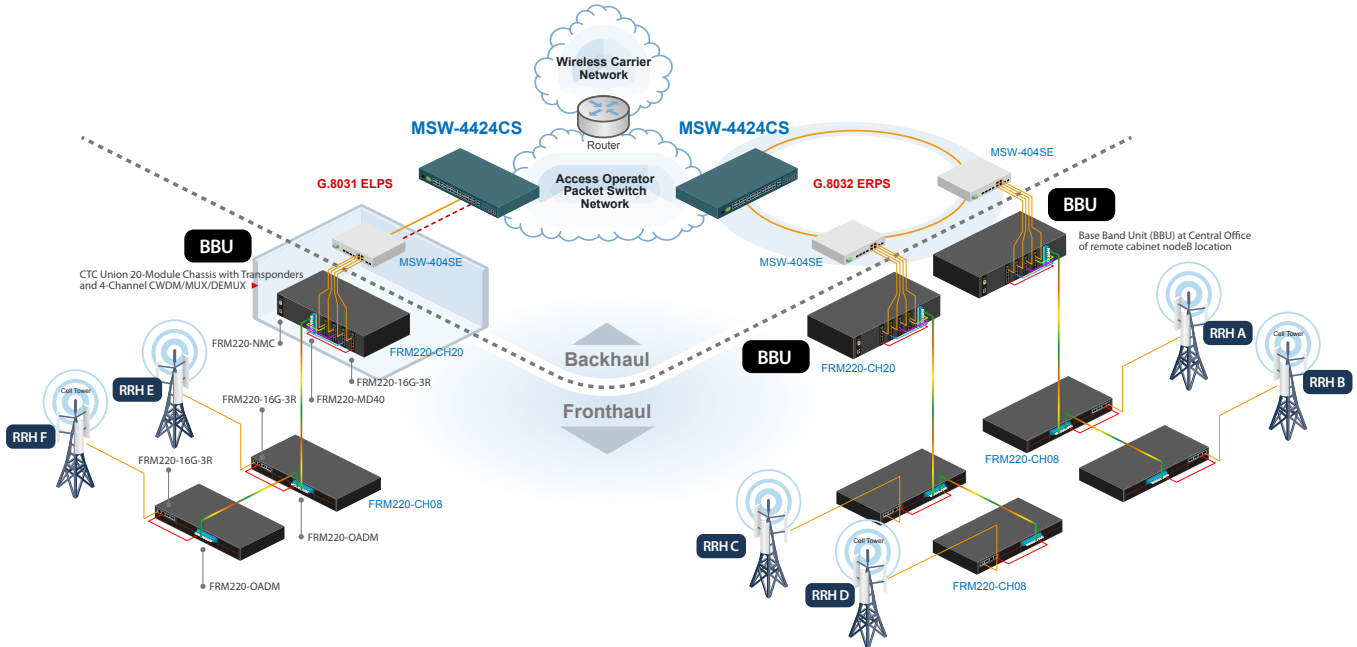

- Carrier Ethernet with multiple class of service
- Traffic Synchronization
- Precisely delivery of time-sensitive service

Ordering Information

Model Name	Description
MSW-4424CS-AC	L2+ 10G Fiber Access Switch with SyncE and build-in single AC power module
MSW-4424CS-DC	L2+ 10G Fiber Access Switch with SyncE and build-in single DC power module
MSW-4424CS-AA	L2+ 10G Fiber Access Switch with SyncE and build-in dual AC power module
MSW-4424CS-DD	L2+ 10G Fiber Access Switch with SyncE and build-in dual DC power module
MSW-4424CS-AD	L2+ 10G Fiber Access Switch with SyncE and build-in AC + DC power module

Power Type
MSW - 4424CS -
 Example: MSW - 4424CS - AC

Accessories

10G SFP+ Transceiver Module

SFM-1000-SR85	10G SFP+ SR/SW MMF 300m, 850nm VCSEL, 10G Ethernet/FC/SDH/SONET
SFS-1010-LR31	10G SFP+ LR/LW SMF 10km, 1310nm DFB DML, 10G Ethernet/FC/SDH/SONET
SFS-1040-ER55	10G SFP+ ER/EW SMF 40km, 1550nm DFB EML, 10G Ethernet/FC/SDH/SONET
SFS-1080-ZR55	10G SFP+ ZR/EW SMF 80km, 1550nm DFB EML, 10G Ethernet/FC/SDH/SONET

L2+ Gigabit Carrier Ethernet Switch

CE^{2.0}



MSW-4424C

20x GbE, SFP + 4x GbE Combo + 4x 10GbE (SFP+) L2+ Managed Carrier Ethernet Switch

The MSW-4424C is positioned as a layer 2+ Gigabit access switch solution. It is equipped with 20 100Base-FX/1000Base-X dual speed SFP slots, 4 ports GbE combo (10/100/1000Base-T or 100/1000Base-X SFP) ports and 4 1000Base-X/10G Base-X dual speed SFP+ uplink slots. The MSW-4424C offers the best flexibility and scalability for operators or service providers to deploy their Metro Ethernet network. With the deployment of MSW-4424C, operators or service providers can flexibly provision the bandwidth for either 100Mbps or 1000Mbps as well as uplink connection of Gigabit or 10G speed in their service applications. The MSW-4424C has built-in dual power supplies to enable power redundancy and enhance the high network availability.

Aimed at Metro Ethernet applications, the specifications of MSW-4424C fully meet the attributes of Carrier Ethernet proposed by MEF (Metro Ethernet Forum). It complies with MEF 9 standard to support E-Line/E-Access service and MEF 14 standard to enable the bandwidth profile configuration delivering SLA (Service Level Agreement) for end-to-end performance characteristics as well as Ethernet OAM functionality to support carrier grade service OAM management rapidly detecting and recovering from the network incidents in real time.

Feature and Benefits

Fully dual rate architecture of fiber link port

Completely dual speed ports of fiber link to offer the scalable physical connection of Metro Ethernet network for operators.

Fully Ethernet OAM enabled

Enabling Ethernet OAM features (IEEE 802.3ah/802.1ag/ITU-T Y.1731) to rapidly detect and recover network fault and save the OPEX for operators as well as increase customer satisfaction.

MEF standards compliant solution

CE2.0 compliant product to guarantee the compatibility with other MEF certified equipment and reduce the risk and cost for Metro Ethernet network deployment of operators.

Specifications

Interface	100/1000Mbps SFP slots x 20 + GbE combo port (10/100/1000Base-T or 100/1000Mbps SFP slot) x 4 + 1/10Gbps SFP+ slot x 4
Console Port	RJ-45 console port x 1
Management Port	10/100/1000Base-T RJ45 x 1
Filter & Forward Rate	14880pps at 10Mbps, 148800pps at 100Mbps, 1488000pps at 1Gbps, 14880000pps at 10Gbps
Switching Capacity	128Gbps
Packet Forwarding Capacity	95Mpps
Transmission Method	Store and Forward Switching
Standard	IEEE 802.3u, IEEE 802.3z, IEEE 802.3ae, IEEE 802.1p IEEE 802.1Q, IEEE 802.1ad, IEEE 802.1d, IEEE 802.1w IEEE 802.1s, IEEE 802.1x, IEEE 802.3ad, IEEE 802.3ah IEEE 802.1ag, ITU-T Y.1731
Packet Buffer	32M bits
Mac Table Size	32K
Max. Packet Size	10K Bytes
VLAN Feature	IEEE 802.1Q tagged VLAN (Max. 4K VLAN groups), port based VLAN, MAC based VLAN, protocol based VLAN private VLAN, IEEE 802.1ad Q-in-Q, VLAN translation, GVRP
QoS Feature	IEEE 802.1p 8 priority queues per port, CoS based on switch port; VLAN ID; DSCP; TCP/UDP port IEEE 802.1p priority tag remarking, DSCP remarking, Port based ingress/egress rate limit 3 colors marker-CIR/EIR/Bursts bandwidth control
L2 switching Protection	STP, RSTP, MSTP, ITU-T G.8031/G.8032

Trunking	IEEE 802.3ad LACP (Max. 14 trunking group, Max. 8 ports per trunking group).
Security	IEEE 802.1x port based access control MAC based access control authentication RADIUS authentication, limited MAC address learning IP/MAC binding, ACL rule based filtering, TACACS+ IP source guard, DHCP snooping/relay option 82 ARP inspection
IP Multicasting	IGMP throttling, IGMP filtering, IGMP fast leave IGMP snooping v1/v2/v3, MVR, MLD snooping v1/v2
Storm Control Management	Unicast/Broadcast/Multicast storm suppression Web/Telnet CLI/SNMP/console interface, Web/CLI authentication, SSH v2, HTTPs, port mirroring syslog, IPv6 management, NTP, SNTP
SNMP agent	SNMP v1/v2c/v3, RMON Group 1,2,3 and 9
Software upgrade	TFTP/HTTP
Ethernet OAM	IEEE 802.3ah/IEEE 802.1ag/ITU-T Y.1731
LED display	Power, System, Console, Link/Act, Speed
Power input	100V ~ 240V AC, -36 ~ -60V DC
Build in power module combination	AC, DC, AD (AC+DC), AA (AC+AC) or DD (DC+DC)
Power Consumption	< 60W
Operating Temperature	0 ~ 50°C
Humidity	5% ~ 90% (non-condensing)
Dimensions	250x 440x 43.5mm (DxWxH)
Certification	FCC, CE

Application

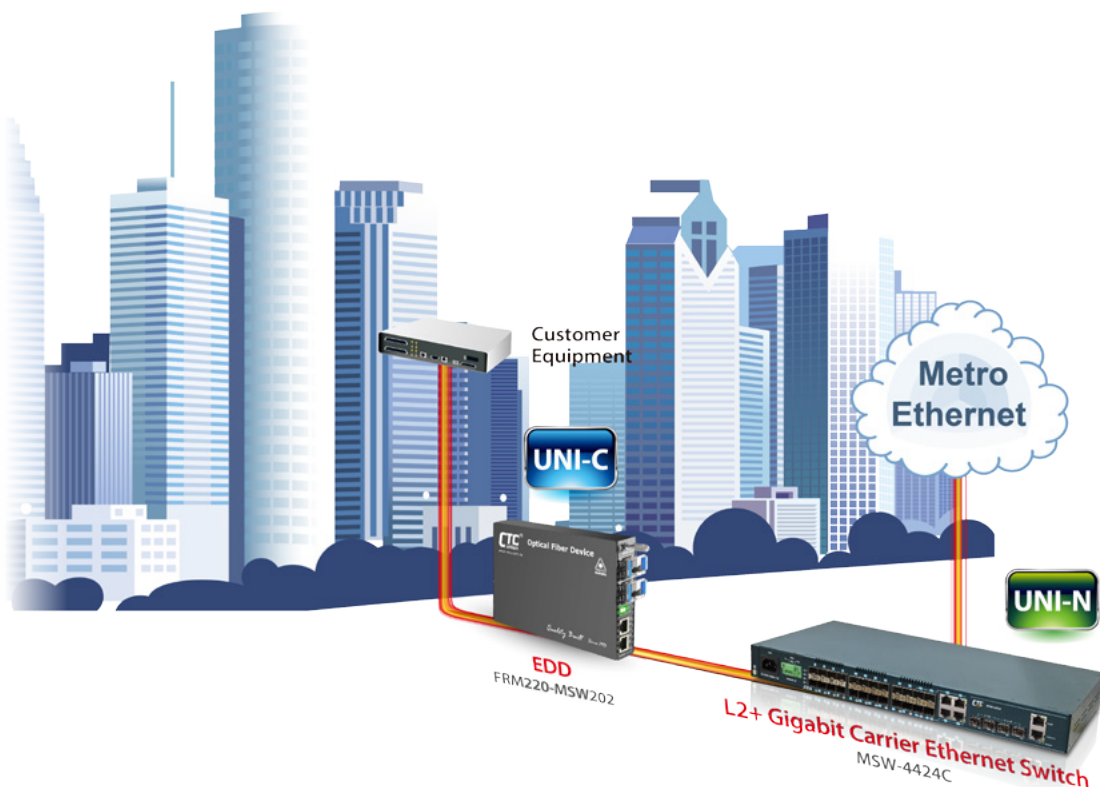

Ordering Information

Model Name	Description
MSW-4424C-AC	L2+ 10G Fiber Access Switch with build-in single AC power module
MSW-4424C-DC	L2+ 10G Fiber Access Switch with build-in single DC power module
MSW-4424C-AA	L2+ 10G Fiber Access Switch with build-in dual AC power module
MSW-4424C-DD	L2+ 10G Fiber Access Switch with build-in dual DC power module
MSW-4424C-AD	L2+ 10G Fiber Access Switch with build-in AC + DC power module

MSW – 4424C – Power Type
 Example: MSW – 4424C – AC

Accessories

10G SFP+ Transceiver Module

SFM-1000-SR85	10G SFP+ SR/SW MMF 300m, 850nm VCSEL, 10G Ethernet/FC/SDH/SONET
SFS-1010-LR31	10GSFP+ LR/LW SMF 10km, 1310nm DFB DML, 10G Ethernet/FC/SDH/SONET
SFS-1040-ER55	10G SFP+ ER/EW SMF 40km, 1550nm DFB EML, 10G Ethernet/FC/SDH/SONET
SFS-1080-ZR55	10G SFP+ ZR/EW SMF 80km, 1550nm DFB EML, 10G Ethernet/FC/SDH/SONET



GSW-3424FM

24x GbE, SFP + 4x GbE RJ45 + 4x 1G/10G, SFP+
L2+ Managed Ethernet Switch

GSW-3424FM is an SNMP manageable Gigabit Ethernet switch for FTTx deployment or Gigabit Ethernet fiber aggregation that is equipped with 24 dual rate 100/1000Base-X SFP ports, 4 10/100/1000Base-T RJ45 ports and 4 1G/10Gbps dual rate SFP+ slots. With advanced layer 2 and QoS features, this switch is targeted at multi-service operators (MSO) with a desire to deploy provisioned triple play services via active Ethernet FTTx network infrastructures. Fiber based network infrastructures offer the data rates required by triple play services such as high speed internet access, VoIP and HD IPTV. The GSW-3424FM Ethernet access switch provides VLAN, QoS and IGMP L2 feature sets as well as robust security management to facilitate service provider's build out of a manageable and secure FTTx access network.

Feature

- IPv6 management
- 8 priority queues are supported on each port for QoS application
- Port-based VLAN, 802.1Q VLAN, Voice VLAN and Q-in-Q(double tagging) function
- Protected Port and LoopBack Detection function
- IEEE 802.1x security function, and VLAN assignment, Guest VLAN functions
- Static Mac address access limit and Dynamic Mac address number on port
- IEEE802.1d & 802.1w & 802.1s
- DHCP Client / DHCP Option 82 Relay / DHCP Snooping function
- DHCP Snooping Database agent to upload DHCP Snooping table to external TFTP Server.
- ACL function for L2 ~ L4 packet control, Ingress/Egress rate control on port
- IP Multicast with IGMP snooping / query / fast leave / filtering / group limited /MVR
- Broadcast/Multicast/Unicast storm control
- ARP inspection / IP source guard
- RMON 1,2,3,9
- SFP Transceiver DDMI function
- Remote port configuration setting and statistics monitoring
- Text configuration download and upload
- IEEE 802.3az power management / Green Ethernet

Specifications

System	
100/1G SFP Port	24
10/100/1000 Base-T RJ45	4
1G/10G Uplink Port	4
Memory	Flash : 16MB / RAM: 128MB
Packet buffer	32M bits
MAC Table size	32K
Max Packet Size	14K
Filter & Forward rate	14880pps at 10Mbps, 148800pps at 100Mbps, 1488000pps at 1Gbps, 14880000pps at 10Gbps
Switching Fabric capacity	136Gbps
Packet Forwarding capacity	101.18Mpps
FAN Design	Yes
Console port	RJ-45
19" Rack-Mount	Yes, with kits
SFP DDMI	Yes
Dimension	250x 440x 43.5mm (DxWxH)
Environmental Temperature	Operating : 0 ~ 50°C Storage : -25 ~ 70°C
Humidity	10% ~ 90% (non-condensing)
LED Display	Per Port : Link/Act (Green: Gigabit, Yellow:10/100M) Per Device : Power and System
Power Consumption	<60W Max.
Power Input	AC Power input (100V~240V); -36~-60VDC
LED	
Power	Lights(Green) System is receiving power
System	Lights(Green) System is ready
Link / Act	Lights Link is ready
	1000Mbps : Green
	100Mbps : Amber
Flashing	Data packets being received or sent

Software	
Port Control	Port speed, duplex mode, and flow control Port Auto MDI/MDI-X Port frame size (jumbo frames), Maximum ingress frame size (10056 bytes) Port state (administrative status) Port status (link monitoring) Port statistics (MIB counters) Port VeriPHY (cable diagnostics)
L2 Switching	Auto MAC address learning/aging and MAC addresses (static) IEEE 802.1Q static VLAN(4096 entries Max.), Voice VLAN Port isolation, Private VLAN, static, MAC based VLAN protocol based VLAN IP subnet based VLAN IEEE 802.1D STP/802.1w RSTP/802.1s MSTP IEEE 802.3ad Link Aggregation, static and LACP BPDU guard and restricted role, Error Disable Recovery DHCP client, DHCP snooping, DHCP option 82 relay ARP inspection(256 entries Max.) Port mirroring
Layer 2 Multicast	IGMP snooping v1,v2, v3 snooping, (1024 groups) IGMP snooping Fast and Immediate leave IGMP throttling, filtering, and leave proxy MVR and MVR profile IPv6 MLD v1 snooping
QoS	8 Priority Queues per Port Port Based priority Scheduler priority QoS Control List(256 entries Max.) Storm control for UC, MC, and BC Policing and shaping per port and per queue Ingress Policing Egress Shaping DiffServ (RFC 2474) remarking Tag remarking

Security	Port-based 802.1X, Single 802.1X, Multiple 802.1X MAC-based authentication, VLAN assignment, QoS assignment, Guest VLAN, RADIUS accounting, MAC address limit, TACACS+, Web and CLI authentication and authorization, Authorization, ACLs for filtering, policing, and port copy, IP source guard
Synchronization	NTPv4 Client
SFP DDMI	Yes

Management	HTTP server, CLI console port, Telnet, Management access filtering, SSHv2 and HTTPS, IPv6 Management, Syslog, Software upload through Web and TFTP, SNMPv1/v2c/v3 Agent, RMON Group 1, 2, 3, and 9, IEEE 802.1AB-2005 Link Layer Discovery, LLDP, Text Configuration download or upload, sFlow, Daylight Saving
-------------------	---

Application

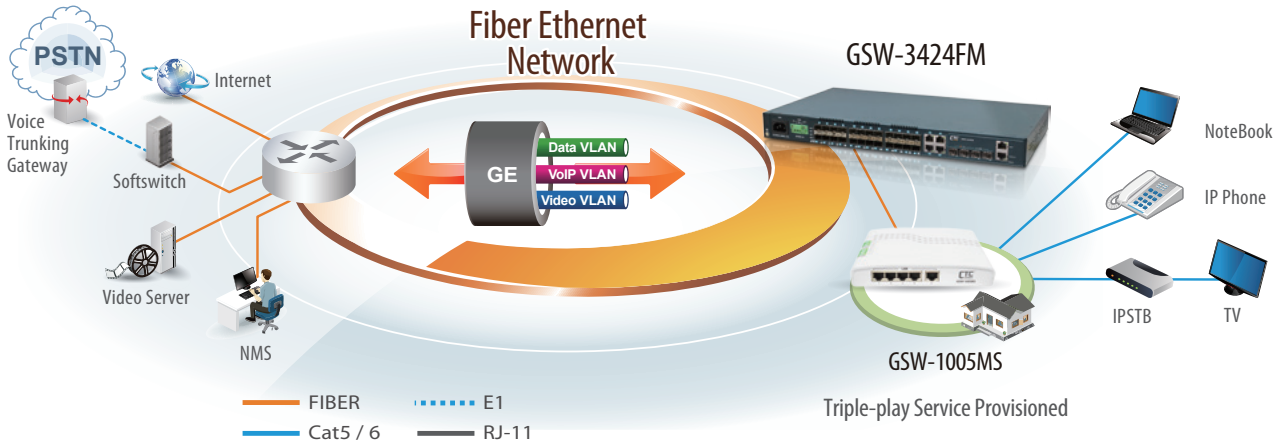

Ordering Information

Model Name	Description
GSW-3424FM-AC	24x GbE SFP slots + 4x GbE RJ45 + 4x 1G/10Gbps SFP+ slots uplink with single AC power supply
GSW-3424FM-DC	24x GbE SFP slots + 4x GbE RJ45 + 4x 1G/10Gbps SFP+ slots uplink with single DC power supply (-48V)
GSW-3424FM-AA	24x GbE SFP slots + 4x GbE RJ45 + 4x 1G/10Gbps SFP+ slots uplink Dual AC power supply
GSW-3424FM-DD	24x GbE SFP slots + 4x GbE RJ45 + 4x 1G/10Gbps SFP+ slots uplink Dual DC power supply (-48V)
GSW-3424FM-AD	24x GbE SFP slots + 4x GbE RJ45 + 4x 1G/10Gbps SFP+ slots uplink AC & DC (-48V) power supply

Power Type
GSW - 3424FM -
 Example: GSW - 3424FM - AD

Accessories

10G SFP+ Transceiver Module

SFM-1000-SR85	10G SFP+ SR/SW MMF 300m, 850nm VCSEL, 10G Ethernet/FC/SDH/SONET
SFS-1010-LR31	10G SFP+ LR/LW SMF 10km, 1310nm DFB DML, 10G Ethernet/FC/SDH/SONET
SFS-1040-ER55	10G SFP+ ER/EW SMF 40km, 1550nm DFB EML, 10G Ethernet/FC/SDH/SONET
SFS-1080-ZR55	10G SFP+ ZR/EW SMF 80km, 1550nm DFB EML, 10G Ethernet/FC/SDH/SONET



GSW-3420FM

20x GbE, SFP + 4x GbE Combo (SFP or RJ45) L2+ Managed Ethernet Switch

GSW-3420FM is an SNMP manageable Gigabit Ethernet switch for FTTx deployment or Gigabit Ethernet fiber aggregation that equipped 20 dual rate 100/1000Base-X SFP ports and 4 Gigabit Ethernet combo (10/100/1000Base-T or 1000Base-X) ports. With advanced layer 2 and QoS features, this switch is targeted at multi-service operators (MSO) with a desire to deploy provisioned triple play services via active Ethernet FTTx network infrastructures. Fiber based network infrastructures offer the data rates required by triple play services such as high speed internet access, VoIP and HD IPTV. The GSW-3420FM Ethernet access switch provides VLAN, QoS and IGMP L2 feature sets as well as robust security management to facilitate service provider's build out of a manageable and secure FTTx access network.

Feature

- 20x SFP ports, support 100Base-FX or 1000Base-X
- 4x RJ45/SFP(100/1G) ports, auto-detect RJ45/SFP connection
- IPv6 management
- 8 priority queues are supported on each port for QoS application
- Port-based VLAN, 802.1Q VLAN, Voice VLAN and Q-in-Q(double tagging) function
- Protected Port and LoopBack Detection function
- IEEE 802.1x security function, and VLAN assignment, Guest VLAN functions
- Static Mac address access limit and Dynamic Mac address number on port
- IEEE802.1d & 802.1w & 802.1s
- IP Multicast with IGMP snooping / query / fast leave / filtering / group limited /MVR
- DHCP Client / DHCP Option 82 Relay / DHCP Snooping function
- ACL function for L2 ~ L4 packet control, Ingress/Egress rate control on port
- Broadcast/Multicast/Unicast storm control
- ARP inspection / IP source guard
- RMON 1,2,3,9
- SFP Transceiver DDMI function
- Remote port configuration setting and statistics monitoring
- Text configuration download and upload
- IEEE 802.3az power management / Green Ethernet

Specifications

System		
100/1G SFP Port	20	
UTP/SFP Combo Port	4	
CPU	416MHz MIPS 24KEc CPU as the main processor which integrated on switch controller	
Memory	Flash : SPI 16MB / RAM:DDRII 128MB	
Packet buffer	2M Bytes	
MAC Table size	16K	
Max Packet Size	9600 Bytes	
Switching capability	14880pps at 10Mbps, 148800pps at 100Mbps, 1488000pps at 1Gbps	
Switch capacity	48Gbps	
Forwarding Rate	35.7Mpps	
FAN Design	Yes	
Console port	D-Sub 9	
19" Rack-Mount	Yes, with kits	
SFP DDMI	Yes	
Dimension	172 x 440 x 44 mm (D x W x H)	
Environmental Temperature	Operating : 0 ~ 50°C Storage : -25 ~ 70°C	
Humidity	10% ~ 90% (non-condensing)	
LED Display	Per Port : Link/Act (Green: Gigabit, Yellow:10/100M) Per Device : Power and System	
Power Consumption	<30W Max.	
Power Input	AC Power input (100V~240V)	
LED	Status	Condition
Power	Lights(Green)	System is receiving power
System	Lights(Green)	System is ready
Link / Act	Lights	Link is ready
		1000Mbps : Green
		100Mbps : Amber
	Flashing	Data packets being received or sent

Software	
Port Control	Port speed, duplex mode, and flow control Port Auto MDI/MDI-X Port frame size (jumbo frames), Maximum ingress frame size (10056 bytes) Port state (administrative status) Port status (link monitoring) Port statistics (MIB counters) Port VeriPHY (cable diagnostics)
L2 Switching	Auto MAC address learning/aging and MAC addresses (static) IEEE 802.1Q static VLAN(4096 entries Max.), Voice VLAN Port isolation, Private VLAN, static, MAC based VLAN protocol based VLAN IP subnet based VLAN IEEE 802.1D STP/802.1w RSTP/802.1s MSTP IEEE 802.3ad Link Aggregation, static and LACP BPDU guard and restricted role, Error Disable Recovery DHCP client, DHCP snooping, DHCP option 82 relay ARP inspection(256 entries Max.) Port mirroring
Layer 2 Multicast	IGMP snooping v1,v2, v3 snooping, (1024 groups) IGMP snooping Fast and Immediate leave IGMP throttling, filtering, and leave proxy MVR and MVR profile IPv6 MLD VI snooping
QoS	8 Priority Queues per Port Port Based priority Scheduler priority QoS Control List(256 entries Max.) Storm control for UC, MC, and BC Policing and shaping per port and per queue Ingress Policing Egress Shaping DiffServ (RFC 2474) remarking Tag remarking

Security	Port-based 802.1X, Single 802.1X, Multiple 802.1X MAC-based authentication, VLAN assignment, QoS assignment, Guest VLAN RADIUS accounting MAC address limit TACACS+ Web and CLI authentication and authorization Authorization ACLs for filtering, policing, and port copy IP source guard
Synchronization	NTPv4 Client
SFP DDMI	Yes

Management	HTTP server CLI console port Telnet Management access filtering SSHv2 and HTTPS IPv6 Management System Syslog Software upload through Web and TFTP SNMPv1/v2c/v3 Agent RMON Group 1, 2, 3, and 9 IEEE 802.1AB-2005 Link Layer Discovery, LLDP Text Configuration download or upload sFlow Daylight Saving
-------------------	--

Application

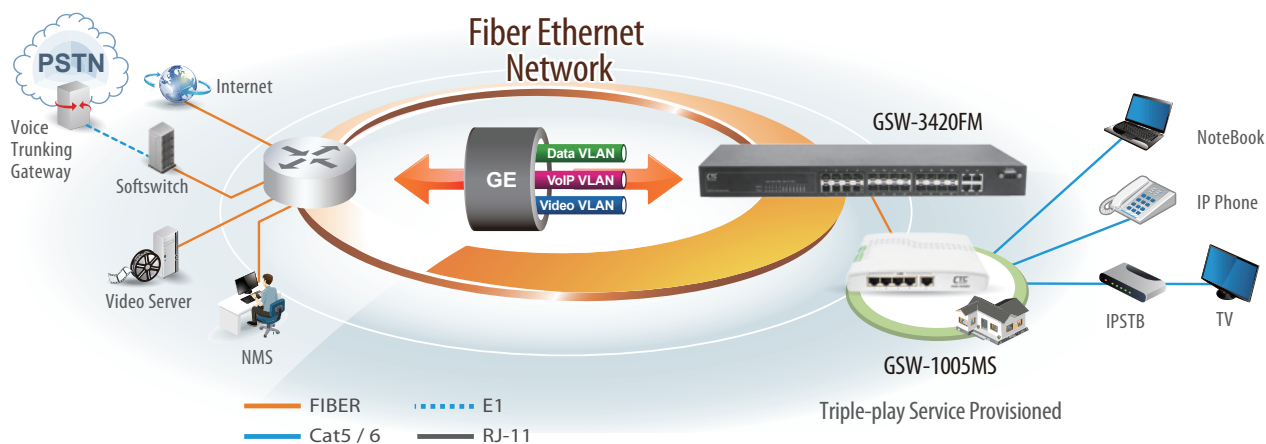

Ordering Information

Model Name	Description
GWS-3420FM-AC	20x 100/1000Base-X SFP slots + 4x GbE combo ports L2+ Switch with single AC Power Supply
GWS-3420FM-AD	20x 100/1000Base-X SFP slots + 4x GbE combo ports L2+ Switch AC & DC Power Supply

Power Type
GWS - 3420FM -
 Example: GWS - 3420FM - AD



GSW-3424M1

20x GbE, RJ45 + 4x GbE Combo (SFP or RJ45) L2+ Managed Switch

GSW-3424M1 is a cost-effect, high performance, managed L2 Ethernet with 20x 10/100/1000Base-T ports and 4x Gigabit Ethernet combo (10/100/1000Base-T or 1000Base-X) ports. This switch supports remote management by SNMP, HTTP(HTTPS) and Telnet(SSH) interfaces along with local management by console interface. GSW-3424M1 supports many L2 switch management functions, including 802.1Q VLAN, 802.1x Port Security, Rate Control, Port Configuration, Port Mirroring, Port Statistics, QoS functions, Spanning tree and more.

Feature

- 20x RJ45 ports, with 10/100/1000Mbps, Full/Half duplex auto-negotiation and Auto-MDIX functions
- 4x Dual Speed SFP sockets, shared with TX ports of Port 21~24 ;
- auto-detect TX/SFP connection
- CISCO-like command line interface, IPv6 management
- 8 priority queues are supported on each port for QoS application
- Port-based VLAN, 802.1Q VLAN, Voice VLAN and Q-in-Q (double tagging) function
- Protected Port and LoopBack Detection function
- IEEE 802.1x security function, and VLAN assignment, Guest VLAN functions
- Static Mac address access limit and Dynamic Mac address number on port
- IEEE802.1d & 802.1w & 802.1s (spanning tree)
- IP Multicast with IGMP snooping / query / fast leave / filtering / group limited /MVR
- DHCP Client / DHCP Option 82 Relay / DHCP Snooping function
- ACL function for L2 ~ L4 packet control, Ingress/Egress rate control on port
- Broadcast/Multicast/Unicast storm control
- ARP inspection / IP source guard, RMON 1, 2, 3, 9
- SFP Transceiver DDMI function / Dual Speed SFP Ports (100/1000Mbps)
- Remote port configuration setting and statistics monitoring
- Text configuration download and upload
- IEEE 802.3az power management / FANless / Green Ethernet

Specifications

System		Software	
10/100/1000 Base-T	20	Port Control	Port speed, duplex mode, and flow control Port frame size (jumbo frames), Maximum ingress frame size (9600 bytes) Port state (administrative status) Port status (link monitoring) Port statistics (MIB counters) Port VeriPHY (cable diagnostics), Power Control
100/1G SFP Slot	4 UTP/SFP Combo (Port 21~24)	L2 Switching	Auto MAC address learning/aging and MAC addresses (static) IEEE 802.1Q static VLAN(Max. 4K VLAN groups), Voice VLAN, Port isolation, Port Based VLAN, IEEE 802.1ad Provider Bridge IEEE 802.1D STP/802.1w RSTP/802.1s MSTP IEEE 802.3ad Link Aggregation, static and LACP BPDU guard and restricted role, BPDU transparency DHCP client, DHCP snooping, DHCP option 82 relay ARP inspection, Port mirroring, IP MAC binding
Packet buffer	512KB	Layer 2 Multicast	IGMP snooping v1,v2, v3 snooping, (1024 groups) IGMP snooping Fast and Immediate leave IGMP throttling, filtering, and leave proxy IGMP proxy mode and snooping mode selection MVR, IPv6 MLD snooping
MAC Table size	8K	QoS	8 Priority Queues per Port Port Based priority, Scheduler priority, QoS Control List Storm control for UC, MC, and BC Policing and shaping per port and per queue Ingress Policing : (100-1000000 when the "Unit" is "kbps" or "fps" and 1-3300 when the "Unit" is "Mbps" or "kfps") Egress Shaping : (100-1000000 when the "Unit" is "kbps", and 1-3300 when the "Unit" is "Mbps") DiffServ (RF 2474) remarking, Tag remarking
Max Packet size	9600 Bytes		
Filter & Forward rate	14880pps at 10Mbps, 148800pps at 100Mbps, 1488000pps at 1Gbps		
Switching Fabric capacity	48Gbps		
Packet Forwarding capacity	35.7Mpps		
FAN Design	FAN less		
Console port	D-Sub 9		
19" Rack-Mount	Yes, with kits		
SFP DDMI	Yes		
Dimensions	330 x 204 x 44 mm (W x D x H)		
Environmental Temperature	Operating : 0 ~ 50°C Storage : -40 ~ 70°C		
Humidity	10% ~ 90% (non-condensing)		
LED Display	Per Port : Link/Act (Green: Gigabit, Yellow:10/100M) Per Device : Power and System		
Power Consumption	18 Watt Max.		
Power Input	AC Power input (100V~240V)		

Security

Port-based 802.1X, Single 802.1X, Multiple 802.1X
 MAC-based authentication, VLAN assignment, QoS
 assignment,
 Guest VLAN, RADIUS accounting, MAC address limit
 TACACS+, Web and CLI authentication and
 authorization
 Authorization (3 levels)
 ACLs for filtering(256 entries), policing, and port
 copy
 IP source guard

Synchronization

NTPv4 Client

Power Saving

ActiPHY, PerfectReach,
 Ethernet Energy Efficient power management(EEE)

SFP DDMI

Yes

Management

HTTP server, CLI console port, Telnet,
 Management access filtering, SSHv2 and HTTPS
 IPv6 Management, System Syslog
 Software download through Web, SNMPv1/v2c/v3
 Agent
 RMON Group 1, 2, 3, and 9
 IEEE 802.1AB-2005 Link Layer Discovery, LLDP
 Text Configuration download or upload, sFlow,
 Daylight Saving

Application

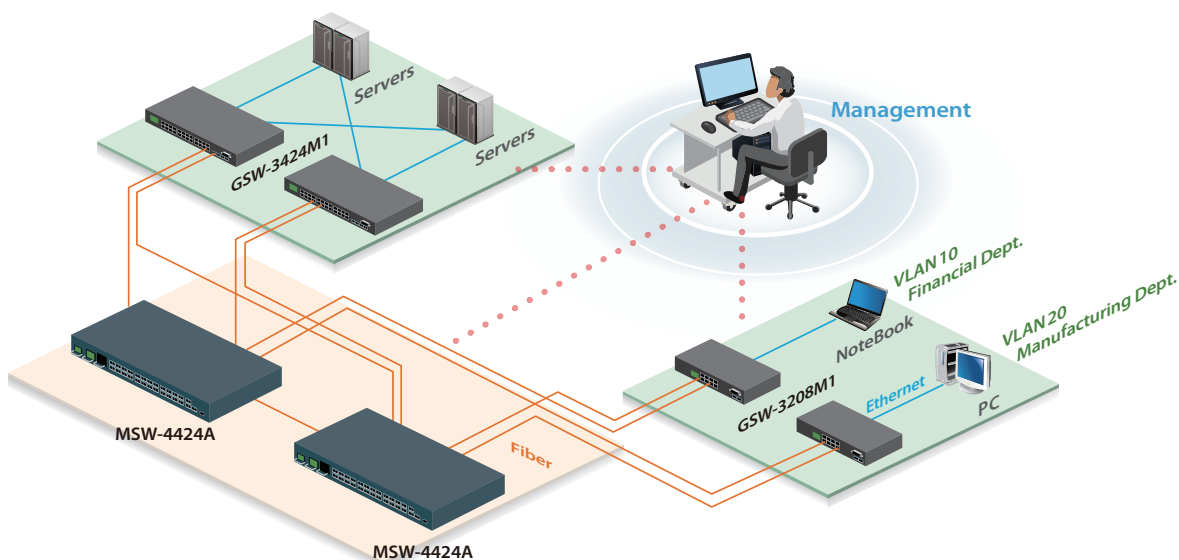

— FIBER — E1
 — Cat5 / 6 — RJ-11

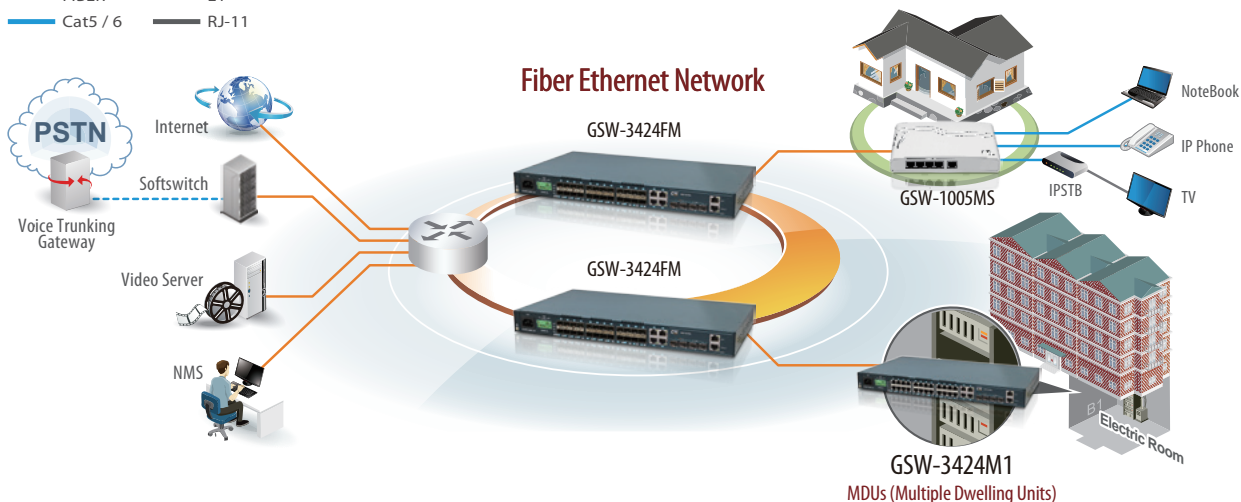

Ordering Information

Model Name	Description
GSW-3424M1-AC	20x 10/100/1000Base-T + 4x GbE Combo with AC power supply
GSW-3424M1-DC48	20x 10/100/1000Base-T + 4x GbE Combo with DC 48V power supply

Power Type
MSW - 3424M1 -
 Example: MSW - 3424M1 - DC48



GSW-3216M1

16x GbE, RJ45 + 2x GbE, SFP
L2+ Managed Switch

GSW-3216M1 is a cost-effect, high performance, managed L2 Ethernet with 16x 10/100/1000Base-T ports and 2x Gigabit Ethernet 1000Base-X ports. This switch supports remote management by SNMP, HTTP and Telnet interfaces along with local management by console interface. GSW-3216M1 supports many L2 switch management functions, including 802.1Q VLAN, 802.1x Port Security, Rate Control, Port Configuration, Port Mirroring, Port Statistics, QoS functions, Spanning tree and more.

Feature

- 16x RJ45 ports, with 10/100/1000Mbps, Full/Half duplex auto-negotiation and Auto-MDIX functions
- 2x Dual Speed SFP sockets, port 17 and port 18
- CISCO-like command line interface, IPv6 management
- 8 priority queues are supported on each port for QoS application
- Port-based VLAN, 802.1Q VLAN, Voice VLAN and Q-in-Q (double tagging) function
- Protected Port and LoopBack Detection function
- IEEE 802.1x security function, and VLAN assignment, Guest VLAN functions
- Static Mac address access limit and Dynamic Mac address number on port
- IEEE802.1d & 802.1w & 802.1s (spanning tree)
- IP Multicast with IGMP snooping / query / fast leave / filtering / group limited /MVR
- DHCP Client / DHCP Option 82 Relay / DHCP Snooping function
- ACL function for L2 ~ L4 packet control, Ingress/Egress rate control on port
- Broadcast/Multicast/Unicast storm control
- ARP inspection / IP source guard, RMON 1,2,3,9
- SFP Transceiver DDMI function / Dual Speed SFP Ports (100/1000Mbps)
- Remote port configuration setting and statistics monitoring
- Text configuration download and upload
- IEEE 802.3az power management / FANless / Green Ethernet

Specifications

System	
10/100/1000 Base-T	16
100/1G SFP Slot	2
Packet buffer	512KB
MAC Table size	8K
Max Packet size	9600 Bytes
Switching capability	14880pps at 10Mbps 148800pps at 100Mbps 1488000pps at 1Gbps
Switch capacity	36Gbps
Forwarding Rate	26.7Mpps
FAN Design	FAN less
Console port	D-Sub 9
19" Rack-Mount	Yes, with kits (optional)
SFP DDMI	Yes
Dimensions	117 x 250 x 37 mm(D x W x H)
Environmental Temperature	Operating : 0 ~ 50°C Storage : -40 ~ 70°C
Humidity	10% ~ 90% (non-condensing)
LED Display	Per Port : Link/Act (Green: Gigabit, Yellow:10/100M) Per Device : Power and System
Power Consumption	14 Watt Max.
Power Input	AC Power input (100V~240V)
LED	
Power	Lights(Green) System is receiving power
System	Lights(Green) System is ready
Link / Act	Lights Link is ready 1000Mbps : Green 10/100Mbps : Amber Flashing Data packets being received or sent

Software	
Port Control	Port speed, duplex mode, and flow control Port frame size (jumbo frames), Maximum ingress frame size (9600 bytes) Port state (administrative status) Port status (link monitoring) Port statistics (MIB counters) Port VeriPHY (cable diagnostics), Power Control
L2 Switching	Auto MAC address learning/aging and MAC addresses (static) IEEE 802.1Q static VLAN(Max. 4K VLAN groups), Voice VLAN, Port isolation, Port Based VLAN, IEEE 802.1ad Provider Bridge IEEE 802.1D STP/802.1w RSTP/802.1s MSTP IEEE 802.3ad Link Aggregation, static and LACP BPDU guard and restricted role, BPDU transparency DHCP client, DHCP snooping, DHCP option 82 relay ARP inspection, Port mirroring, IP MAC binding
Layer 2 Multicast	IGMP v2, v3 snooping, (1024 groups) IGMP throttling, filtering, and leave proxy MVR
QoS	8 Priority Queues per Port Port Based priority, Scheduler priority, QoS Control List Storm control for UC, MC, and BC Policing and shaping per port and per queue Ingress Policing : (100-1000000 when the "Unit" is "kbps" or "fps" and 1-3300 when the "Unit" is "Mbps" or "kfps") Egress Shaping : (100-1000000 when the "Unit" is "kbps", and 1-3300 when the "Unit" is "Mbps") DiffServ (RF 2474) remarking, Tag remarking

Security	Port-based 802.1X, Single 802.1X, Multiple 802.1X MAC-based authentication, VLAN assignment, QoS assignment, Guest VLAN, RADIUS accounting, MAC address limit TACACS+, Web and CLI authentication and authorization Authorization (3 levels) ACLs for filtering(256 entries), policing, and port copy IP source guard
Synchronization	NTPv4 Client
Power Saving	ActiPHY, PerfectReach, Ethernet Energy Efficient power management(EEE)
SFP DDMI	Yes

Management	HTTP server, CLI console port, Telnet, Management access filtering, SSHv2 and HTTPS IPv6 Management, System Syslog Software download through Web, SNMPv1/v2c/v3 Agent RMON Group 1, 2, 3, and 9 IEEE 802.1AB-2005 Link Layer Discovery, LLDP Text Configuration download or upload, sFlow, Daylight Saving
-------------------	--

Application

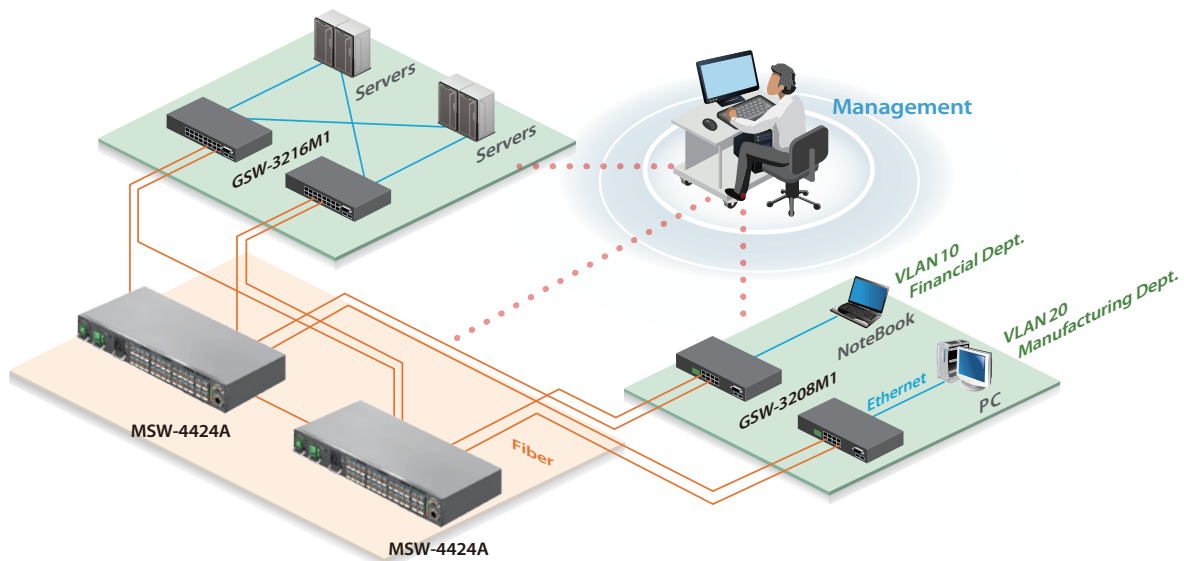

Ordering Information

Model Name	Description
GSW-3216M1-AC	16x 10/100/1000Base-T + 2x GbE(SFP) L2 Switch with AC power supply
GSW-3216M1-DC48	16x 10/100/1000Base-T + 2x GbE(SFP) L2 Switch with DC 48V power supply

Power Type
GSW – 3216M1 –
 Example: **GSW – 3216M1 – DC48**



GSW-3208M2

8x GbE, RJ45 + 2x GbE, SFP L2+ Managed Switch

GSW-3208M2 is positioned as a layer 2 managed switch solution for high speed connectivity with popular traffic priority and management capabilities for small and medium businesses. It features 8-port 10/100/1000Base-T RJ45 and 2-100/1000Base-X SFP based fiber optics. The GSW-3208M2 is designed with a high-performance switching architecture and offers wire-speed transportation capability for bandwidth-intensive applications of enterprises. More and more corporations are adapting new IT technologies over the network such as voice over IP, video conference to improve productivity and save operation expenditure. The GSW-3208M2 also supports features such as VLAN, QoS, IGMP for multicast applications and network management to fulfill SMB requirements. The GSW-3208M2 delivers a cost effective Gigabit Ethernet solution to meet the converged applications for enterprise customer's networks.

Feature

- 8-port 10/100/1000Base-T RJ45 + 2 uplink 100/1000Base-X SFP slot
- Supports 9K Bytes jumbo frame
- Supports IEEE 802.1Q tagged VLAN & Q-in-Q VLAN stacking
- Supports IEEE 802.1p priority queue
- Supports IGMP snooping v1/v2/v3
- Supports dying gasp
- Supports power redundancy (optional)

Specifications

Interface	8x 10/100/1000Base-T(X) RJ-45 with 2x 100/1000Base-X SFP	Security	Port based/single/multiple IEEE 802.1x access control MAC based access control authentication RADIUS authentication, limited MAC address learning IP/MAC binding, ACL rule based filtering TACACS+, IP source guard DHCP snooping/relay option 82 ARP inspection
Console port	D-Sub 9	IP multicasting	IGMP throttling, IGMP filtering, IGMP fast leave, IGMP snooping v1/v2/v3, MVR, MLD snooping v1
FAN design	Fanless	Storm Control Management	Unicast/Broadcast/Multicast storm suppression Web/Telnet CLI interface, Web/CLI authentication, SSH v2, HTTPs, port mirroring, system syslog, IPv6 management, NTP, text based configuration upload or download, IEEE 802.1ab LLDP, Cisco discovery filtering (CDP), sFlow, DHCP auto provisioning
19" rack mountable	Yes, with kits (optional)	SNMP agent	SNMP v1/v2c/v3, RMON Group 1,2,3 and 9
Switching fabric capacity	20Gbps	Software upgrade	TFTP/HTTP
Filter & Forward rate	14880pps at 10Mbps, 148800pps at 100Mbps, 1488000pps at 1Gbps	Power input	100 ~ 240VAC -18 ~ -60VDC (-48VDC)
Transmission method	Store and Forward Switching	Operating Temperature	0 ~ 50°C
Standard	IEEE 802.3u, IEEE 802.3z, IEEE 802.3ae, IEEE 802.3x, IEEE 802.1p, IEEE 802.1Q, IEEE 802.1ad, IEEE 802.1x, IEEE 802.1D, IEEE 802.1w, IEEE 802.1s, IEEE 802.3ad, IEEE 802.1ab	Humidity	5% ~ 90% (non-condensing)
Packet buffer	4M bits	Dimensions	250 x 117 x 43.8 mm
MAC table size	8K	Certification	FCC, CE
Jumbo frame size	9600 Bytes		
VLAN feature	IEEE 802.1Q tagged VLAN (Max. 4K VLAN groups) MAC based VLAN Protocol based VLAN Private VLAN for port isolation IP subnet based VLAN, Voice VLAN VLAN translation, IEEE 802.1ad Q-in-Q		
L2 switching protection	STP, RSTP, MSTP		
Trunking	IEEE 802.3ad LACP		
QoS feature	IEEE 802.1p 8 priority queues per port, Port Default Priority, User Priority, Input priority mapping, QoS Control List (QCL Mode), Storm Control for UC, BC and Unknown, Port policers, Global/VCAP (ACL) policers, Port egress shaper, Queue egress shapers, DiffServ (RFC2474) remarking, Tag remarking, Scheduler mode		

Application

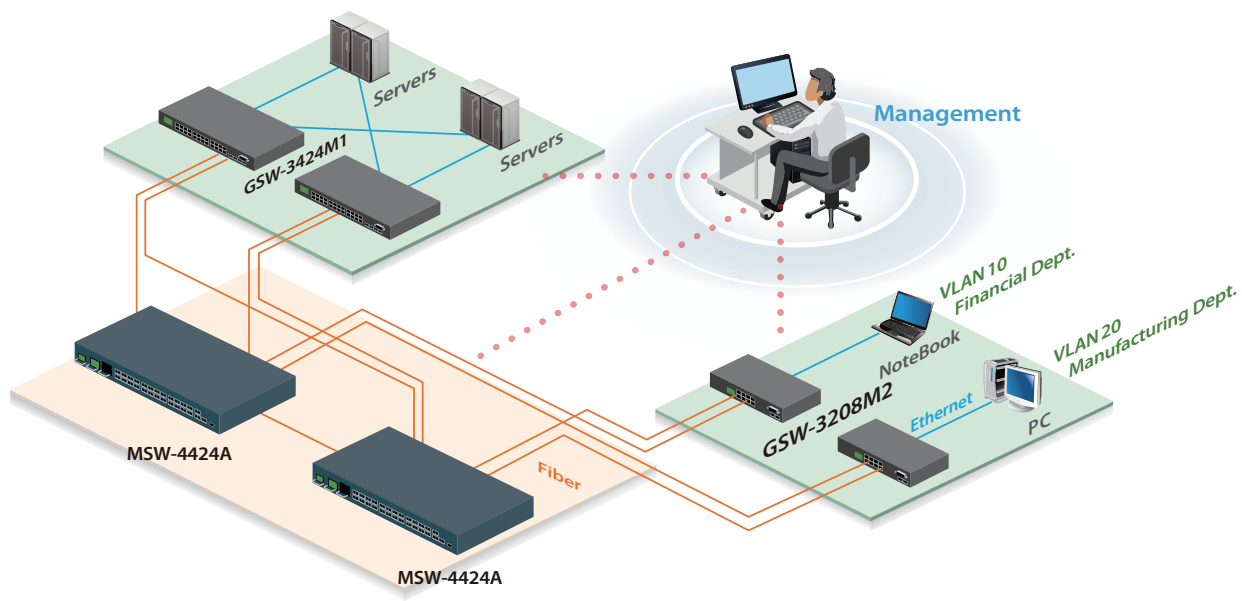

- FIBER
- Cat5 / 6
- - - E1
- RJ-11

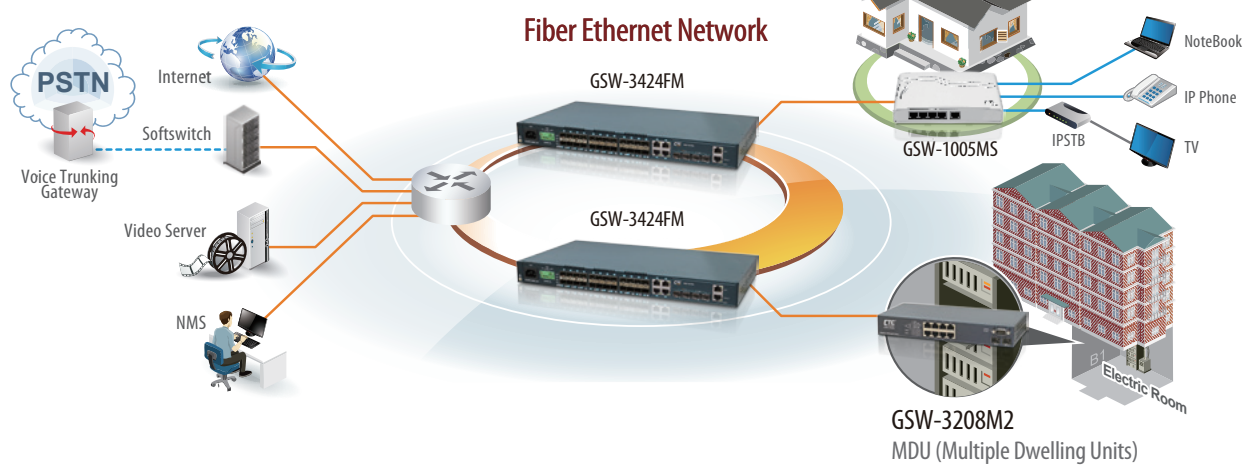

Ordering Information

Model Name	Description
GSW-3208M2-AC	8x 10/100/1000Base-T + 2x GbE SFP slot L2 Managed Switch with AC power supply
GSW-3208M2-DC48	8x 10/100/1000Base-T + 2x GbE SFP slot L2 Managed Switch with DC 48V power supply

Accessories

GSW-3208M2-RMK	19" rack mount kit of GSW-3208M2
----------------	----------------------------------

Remark: SFP Transceiver not included

Power Type
GSW - 3208M2 -
 Example: **GSW - 3208M2 - DC48**



MSW-404SE

4x GbE, RJ45 + 4x Dual Rate SFP L2+
Carrier Ethernet Switch (NID) with SyncE

MSW-404SE is a new generation of carrier grade Ethernet demarcation device for business connection and mobile backhaul transportation service delivered by carriers. The MSW-404SE is equipped 4 SFP slots in dual rate 100/1000Base-X and 4 ports 10/100/1000Base-T RJ45 network interfaces. It is designed to enable E-Line, E-LAN, E-Tree services which are CE (Carrier Ethernet) 2.0 compliant for Metro Ethernet network deployments.

MSW-404SE enables carriers and service providers to delivered SLA-based network service with extensive fault detection and diagnostic capabilities which are compliant with the latest Ethernet OAM standards such as IEEE 802.3ah, IEEE 802.1ag and ITU-TY.1731. With built-in RFC2544 feature sets, the MSW-404SE also enables the service providers to perform the SLA verification anytime to ensure the quantitative latency, jitter and throughput delivery performance indexes. The CE2.0 compliant functions support EVCs and 3 colors marker QoS traffic management to enable service providers managing bandwidth and enforce SLA guaranteed.

MEF 22.1 defines the standard for how Metro Ethernet service is adopted into the traffic transportation in the mobile backhaul application. The mobile service is time sensitive and required accurately packet delivery over a clocking synchronized network to transmit packetized data from a mobile device among base stations without loss. The MSW-404SE supports Synchronized Ethernet to fulfill the IP converged services (data, voice, video) over synchronous Ethernet aware carrier Ethernet network.

Feature

- The next generation of Ethernet demarcation device, at customer premise, fulfilling the large-scale carrier Ethernet deployment for intelligent business connection and mobile backhaul services complied to CE 2.0 standard.
- CE2.0 standards compliant product guarantees the fully interoperability with other MEF certified equipment and reduces the risks and cost of Carrier Ethernet network deployment for operators and service providers.
- Advanced clock synchronized features for carrier Ethernet network allows operators to deliver time sensitive services with optimal stability and continuity in the end-to-end connectivity.

Specifications

Interface	100/1000Mbps SFP slots x 4 + 10/100/1000Base-T RJ45 x 4	Security	IEEE 802.1x port based access control, MAC based access control authentication, RADIUS authentication, limited MAC address learning, IP/MAC binding, ACL rule based filtering, TACACS+, IP source guard, DHCP snooping/relay option 82, ARP inspection
Console Port	RJ-45 console port x 1	IP Multicasting	IGMP throttling, IGMP filtering, IGMP fast leave, IGMP snooping v1/v2/v3, MVR, MLD snooping v1/v2
Management port	10/100/1000Base-T RJ45 x 1	Storm Control	Unicast/Broadcast/Multicast storm suppression
1PPS/ToD port	RJ45 x 1	Management	Web/Telnet CLI/SNMP/console interface, Web/CLI authentication, SSH v2, HTTPs, port mirroring, syslog, IPv6 management, NTP, SNTP
BITS E1/T1 Timing	RJ45 x 1	SNMP Agent	SNMP v1/v2c/v3, RMON Group 1,2,3 and 9
Switching Fabric capacity	16Gbps	Software Upgrade	TFTP/HTTP
Filter & Forward rate	14880pps at 10Mbps, 148800pps at 100Mbps, 1488000pps at 1Gbps	Ethernet OAM	IEEE 802.3ah, IEEE 802.1ag, ITU-T Y.1731, RFC2544
Transmission Method	Store and Forward Switching	Timing Synchronization	ITU-T G.8262 Synchronous Ethernet, IEEE 1588v2
Standard	IEEE 802.3u, IEEE 802.3z, IEEE 802.3ae, IEEE 802.3x, IEEE 802.1p, IEEE 802.1Q, IEEE 802.1ad, IEEE 802.1D, IEEE 802.1w, IEEE 802.1s, IEEE 802.1x, IEEE 802.3ad	LED Display	Power, System, Console, Link, Speed/Act
Packet Buffer	8M bits	Power Input	100V ~ 240VAC, -36 ~ -60VDC
MAC Table Size	8K	Power Consumption	< 20W
Max. Packet Size	10K Bytes	Operating Temperature	0 ~ 50°C
VLAN Feature	IEEE 802.1Q tagged VLAN(Max. 4K VLAN groups), port based VLAN, MAC based VLAN, protocol based VLAN, private VLAN, IEEE 802.1ad Q-in-Q, VLAN Translation, GVRP	Humidity	5% ~ 90% (non-condensing)
QoS Feature	IEEE 802.1p 8 priority queues per port, CoS based on switch port; VLAN ID; DSCP; TCP/UDP port, IEEE 802.1p priority tag remarking, DSCP remarking, Port based ingress/egress rate limit 3 colors marker-CIR/EIR/Burst bandwidth control	Dimensions	250 x 218 x 44 mm (D x W x H)
L2 switching protection	STP, RSTP, MSTP, ITU-T G.8031/G.8032 Ethernet ring protection	Regulatory	FCC, CE
Trunking	IEEE 802.3ad LACP (Max. 4 trunking groups, Max. 8 ports per trunking group)		

Application

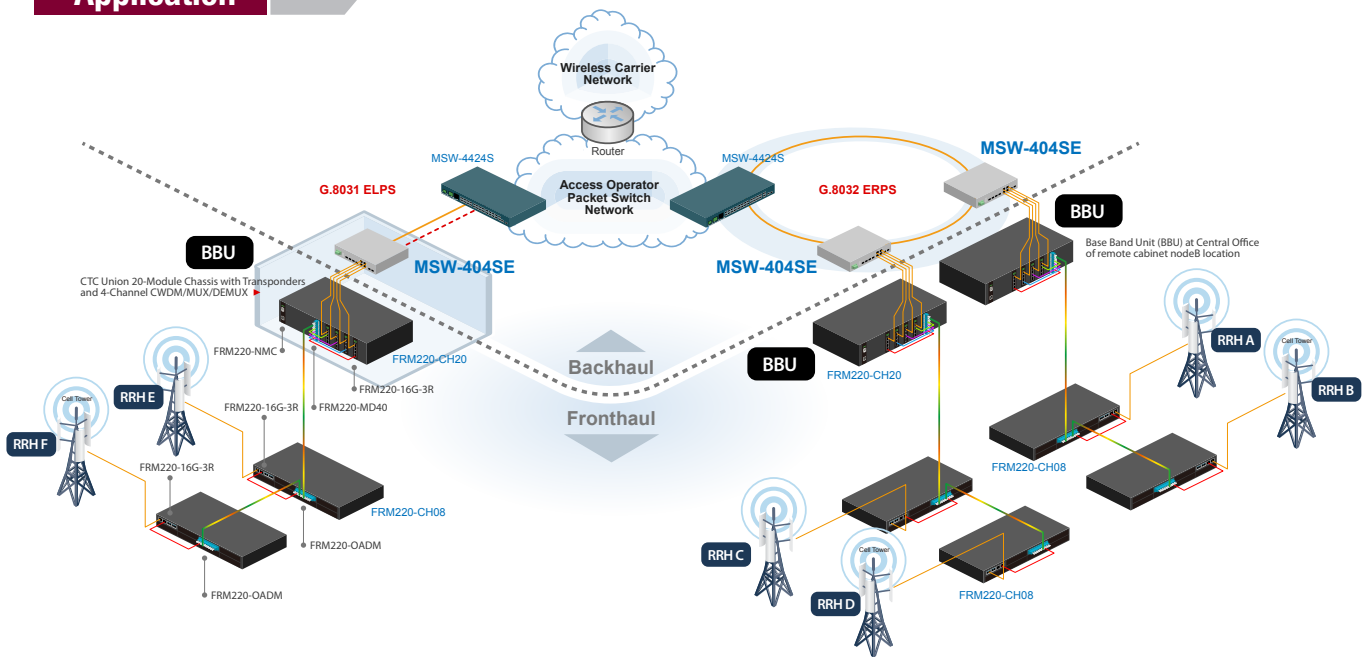

- Carrier Ethernet with multiple class of service
- Traffic Synchronization
- Precisely delivery of time-sensitive service

Ordering Information

Model Name	Description
MSW-404SE-AC	4x 100/1000Base-x SFP slots + 4x 10/100/1000Base-T RJ45 Carrier Ethernet Switch with SyncE & single AC power supply built-in
MSW-404SE-DC	4x 100/1000Base-x SFP slots + 4x 10/100/1000Base-T RJ45 Carrier Ethernet Switch with SyncE & single DC power supply built-in
MSW-404SE-AA	4x 100/1000Base-x SFP slots + 4x 10/100/1000Base-T RJ45 Carrier Ethernet Switch with SyncE & Dual AC power supply built-in
MSW-404SE-DD	4x 100/1000Base-x SFP slots + 4x 10/100/1000Base-T RJ45 Carrier Ethernet Switch with SyncE & Dual DC power supply built-in
MSW-404SE-AD	4x 100/1000Base-x SFP slots + 4x 10/100/1000Base-T RJ45 Carrier Ethernet Switch with SyncE & AC & DC power supply built-in

Power Type
MSW – 404SE-
 Example: MSW – 404SE-AC

Accessories

10G SFP+ Transceiver Module

SFM-1000-SR85	10G SFP+ SR/SW MMF 300m, 850nm VCSEL, 10G Ethernet/FC/SDH/SONET
SFS-1010-LR31	10G SFP+ LR/LW SMF 10km, 1310nm DFB DML, 10G Ethernet/FC/SDH/SONET
SFS-1040-ER55	10G SFP+ ER/EW SMF 40km, 1550nm DFB EML, 10G Ethernet/FC/SDH/SONET
SFS-1080-ZR55	10G SFP+ ZR/EW SMF 80km, 1550nm DFB EML, 10G Ethernet/FC/SDH/SONET



MSW-404

4x 10/100/1000Base-T + 4x 100/1000Base-X
L2+ Gigabit Carrier Ethernet Switch (NID)

MSW-404 is a new generation of carrier grade Ethernet demarcation device for business connection and mobile backhaul transportation service delivered by carriers. The FRM220-MSW404 is equipped 4 SFP slots in dual rate 100/1000Base-X and 4 ports 10/100/1000Base-T RJ45 network interfaces. It is designed to enable E-Line, E-LAN, E-Tree services which are CE (Carrier Ethernet) 2.0 compliant for Metro Ethernet network deployments.

The MSW-404 device enables carriers and service providers to delivered SLA-based network service with extensive fault detection and diagnostic capabilities which are compliant with the latest Ethernet OAM standards such as IEEE 802.3ah, IEEE 802.1ag and ITU-T Y.1731. With built-in RFC2544 feature sets, the MSW-404 also enables the service providers to perform the SLA verification anytime to ensure the quantitative latency, jitter and throughput delivery performance indexes. The CE2.0 compliant functions support EVCs and 3 colors marker QoS traffic management to enable service providers management of bandwidth and to enforce SLA guarantees.

Feature

- The next generation of Ethernet demarcation device, at customer premise, fulfilling the large-scale carrier Ethernet deployment for intelligent business connection and mobile backhaul services complied to CE 2.0 standard.
- CE2.0 standards compliant product guarantees the fully interoperability with other MEF certified equipment and reduces the risks and cost of Carrier Ethernet network deployment for operators and service providers.

Specifications

Interface	100/1000Mbps SFP slots x 4 + 10/100/1000Base-T RJ45 x 4	SNMP Agent	SNMP v1/v2c/v3, RMON Group 1,2,3 and 9
Switching Fabric capacity	16Gbps	Software Upgrade	TFTP/HTTP
Filter & Forward rate	14880pps at 10Mbps, 148800pps at 100Mbps, 1488000pps at 1Gbps	Ethernet OAM	IEEE 802.3ah, IEEE 802.1ag, ITU-T Y.1731, RFC2544
Switching Capacity	16Gbps	LED Display	Power, System, Console, Link, Speed/Act
Transmission Method	Store and Forward Switching	Power Input	100V ~ 240VAC, -18 ~ -75VDC
Standard	IEEE 802.3u, IEEE 802.3z, IEEE 802.3ae, IEEE 802.3x, IEEE 802.1p, IEEE 802.1Q, IEEE 802.1ad, IEEE 802.1D, IEEE 802.1w, IEEE 802.1s, IEEE 802.1x, IEEE 802.3ad	Power Consumption	< 20W
Packet Buffer	8M bits	Operating Temperature	0 ~ 50°C
MAC Table Size	8K	Humidity	5% ~ 90% (non-condensing)
Max. Packet Size	10K Bytes	Dimensions	222.7 x 167.4 x 45.5 mm (D x W x H) (with CH02M Chassis)
VLAN Feature	IEEE 802.1Q tagged VLAN, port based VLAN, MAC based VLAN, protocol based VLAN, private VLAN, IEEE 802.1ad Q-in-Q, VLAN translation, GVRP	Regulatory	FCC, CE
QoS Feature	IEEE 802.1p 8 priority queues per port, CoS based on switch port; VLAN ID; DSCP; TCP/UDP port, IEEE 802.1p priority tag remarking, DSCP remarking, Port based ingress/egress rate limit 3 colors marker-CIR/EIR/Burst bandwidth control		
L2 switching protection	STP, RSTP, MSTP, ITU-T G.8031/G.8032 Ethernet ring protection		
Trunking	IEEE 802.3ad LACP(Max. 4 trunking groups, Max. 8 ports per trunking group)		
Security	IEEE 802.1x port based access control, MAC based access control authentication, RADIUS authentication, limited MAC address learning, IP/MAC binding, ACL rule based filtering, TACACS+, IP source guard, DHCP snooping/relay option 82, ARP inspection		
IP Multicasting	IGMP throttling, IGMP filtering, IGMP fast leave, IGMP snooping v1/v2/v3, MVR, MLD snooping v1/v2		
Storm Control	Unicast/Broadcast/Multicast storm suppression		
Management	Web/Telnet CLI/SNMP/console interface, Web/CLI authentication, SSH v2, HTTPS, port mirroring, syslog, IPv6 management, NTP, SNTP		

Application

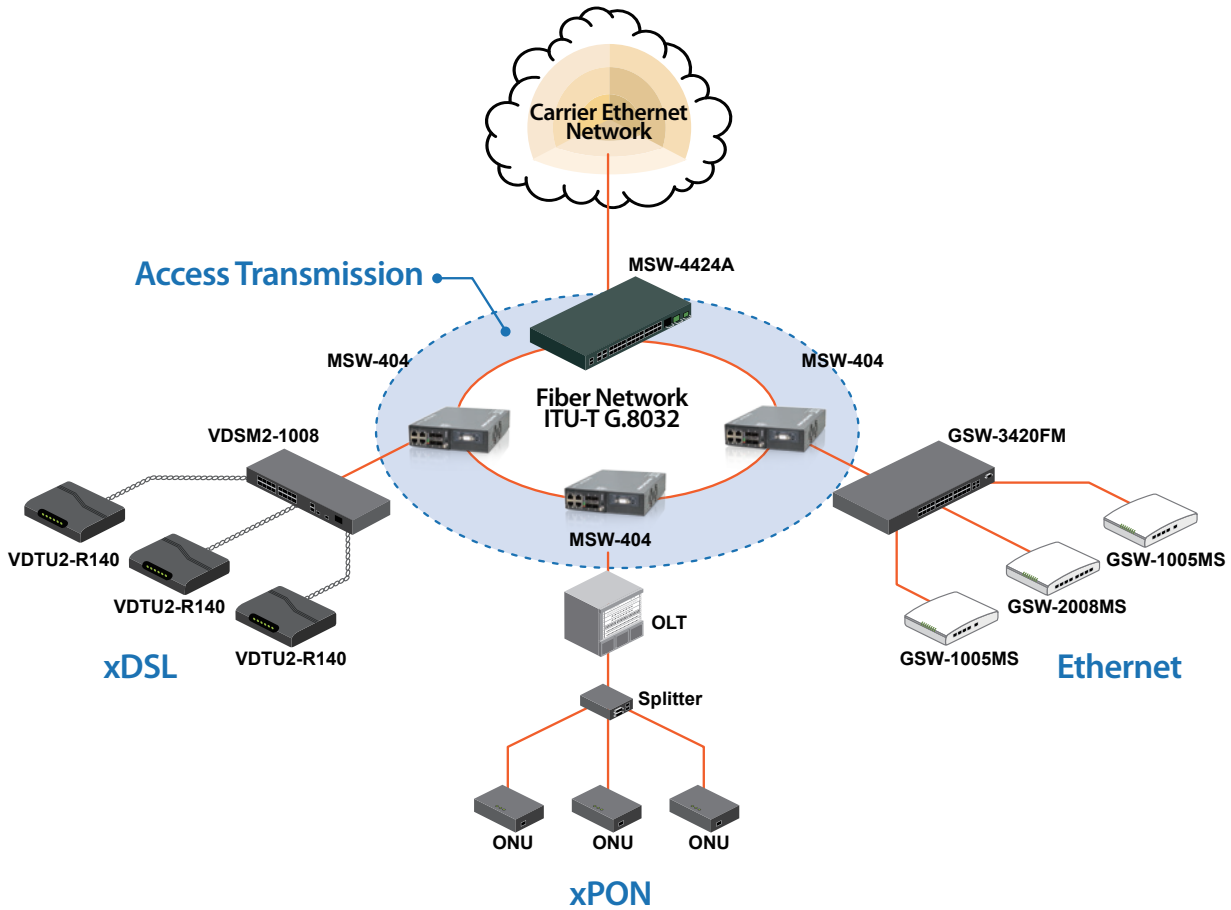

- Carrier Ethernet with multiple class of service
- Traffic Synchronization
- Precisely delivery of time-sensitive service

Ordering Information

Model Name	Description
MSW-404-AC	4x SFP Slots in Dual Rate 100/1000Base-X and 4x 10/100/1000Base-T RJ45 OAM Managed Carrier Ethernet Switch with single AC power supply
MSW-404-DC	4x SFP Slots in Dual Rate 100/1000Base-X and 4x 10/100/1000Base-T RJ45 OAM Managed Carrier Ethernet Switch with single DC power supply
MSW-404-AD	4x SFP Slots in Dual Rate 100/1000Base-X and 4x 10/100/1000Base-T RJ45 OAM Managed Carrier Ethernet Switch with AC & DC power supply

Power Type
MSW – 404 - □□
 Example: MSW – 404 - AC



MSW-202

2x 10/100/1000Base-T + 2x 100/1000Base-X L2+ Gigabit Carrier Ethernet Switch (EDD)

MSW-202 is a carrier class Ethernet Demarcation Device (EDD) with 2x 10/100/1000Base-T Ethernet ports and 2x 100/1000/2500Base-X triple rate SFP fiber ports which enables EPL (Ethernet Private Line) & EVPL (Ethernet Virtual Private Line) services with advanced carrier Ethernet features per the Metro Ethernet Forum (MEF 9 and 14). By supporting link and service Ethernet OAM schemes, the MSW-202 also provides extensive fault detection and diagnostic capabilities to ensure that actual network use complies with pre-agreed service level agreements (SLAs).

Feature

- Complies with MEF CE1.0
- Supports 8K MAC
- Spanning Tree 802.1D, 802.1s, 802.1p
- Supports 802.1Q / 256 active VLANs
- Double VLAN Tagging (C-tag/S-tag) (IEEE 802.1ad) support for ISP application
- Various QoS capability (MAC/port/802.1p/Diffserv)
- Port-based rate limiting
- DHCP Snooping
- IGMP Snooping
- IPv6 support
- IEEE 802.3x and IEEE 802.1x support
- Jumbo frame for up to 9.6K
- Extensive Ethernet OAM support
- IEEE 802.3ah, IEEE 802.1ag, ITU-T Y.1731
- SNMP v1/v2c/v3, Telnet, Web GUI
- IEEE 1588 V2 aware (Optional)

Specifications

Interface	100/1000Mbps SFP slots x 2 + 10/100/1000Base-T RJ45 x 2
Filter & Forward rate	14880pps at 10Mbps, 148800pps at 100Mbps, 1488000pps at 1Gbps
Switching Fabric Capacity	8Gbps
Transmission Method	Store and Forward Switching
Standard	IEEE 802.3u, IEEE 802.3z, IEEE 802.3ab, IEEE 802.3x, IEEE 802.1p, IEEE 802.1Q, IEEE 802.1ad, IEEE 802.1D, IEEE 802.1w, IEEE 802.1s, IEEE 802.1x, IEEE 802.3ad, IEEE802.3ah, IEEE802.1ag, ITU-T Y.1731, ITU-T G.8031, ITU-T G.8032
Packet Buffer	4M bits
MAC Table Size	8K
Max. Packet Size	9.6K Bytes
VLAN Feature	IEEE 802.1Q tagged VLAN(Max. 4K VLAN groups), port based VLAN, MAC based VLAN, protocol based VLAN, private VLAN, IEEE 802.1ad Q-in-Q, VLAN translation, GVRP
QoS Feature	IEEE 802.1p 8 priority queues per port, CoS based on switch port; VLAN ID; DSCP; TCP/UDP port, IEEE 802.1p priority tag remarking, DSCP remarking, Port based ingress/egress rate limit, 3 colors marker-CIR/EIR/Burst bandwidth control
L2 switching protection	STP, RSTP, MSTP, ITU-T G.8031/G.8032 Ethernet ring protection
Trunking	IEEE 802.3ad LACP(Max. 2 trunking groups, Max. 4 ports per trunking group)
Security	IEEE 802.1x port based access control, MAC based access control authentication, RADIUS authentication, limited MAC address learning, IP/MAC binding, ACL rule based filtering, TACACS+, IP source guard, DHCP snooping/relay option 82, ARP inspection
IP Multicasting	IGMP throttling, IGMP filtering, IGMP fast leave, IGMP snooping v1/v2/v3, MVR, MLD snooping v1/v2
Storm Control	Unicast/Broadcast/Multicast storm suppression

Management	Web/Telnet CLI/SNMP/console interface, Web/CLI authentication, SSH v2, HTTPs, port mirroring, syslog, IPv6 management, NTP, SNMP, sFlow
SNMP Agent	SNMP v1/v2c/v3, RMON Group 1,2,3 and 9
Software Upgrade	TFTP/HTTP
Ethernet OAM	IEEE 802.3ah, IEEE 802.1ag, ITU-T Y.1731
LED Display	Power, System, Console, Link, Speed/Act
Power Input	100V ~ 240VAC, -18 ~ -75VDC
Power Consumption	< 12W
Operating Temperature	0 ~ 50°C
Humidity	5% ~ 90% (non-condensing)
Dimensions	201 x 135 x 35 mm (D x W x H) (with CH01M Chassis)
Regulatory	FCC, CE

Application

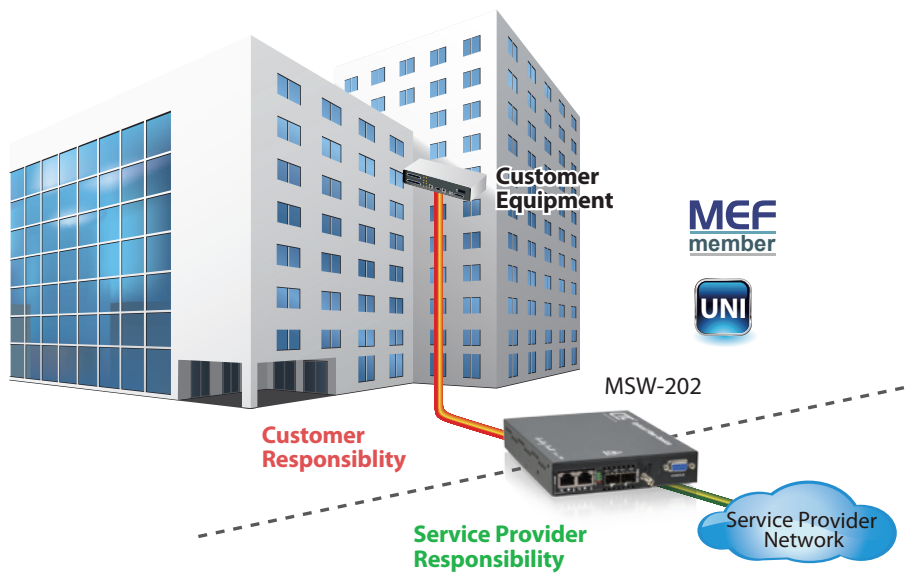

Ordering Information

Model Name	Description
MSW-202-AC	2x SFP Slots in Dual Rate 100/1000Base-X and 2x 10/100/1000Base-T RJ45 OAM Managed Carrier Ethernet Switch with single AC power supply
MSW-202-DC	2x SFP Slots in Dual Rate 100/1000Base-X and 2x 10/100/1000Base-T RJ45 OAM Managed Carrier Ethernet Switch with single DC power supply
MSW-202-AD	2x SFP Slots in Dual Rate 100/1000Base-X and 2x 10/100/1000Base-T RJ45 OAM Managed Carrier Ethernet Switch with AC & DC power supply

Power Type
MSW – 202 - □□
 Example: MSW – 202 - AC



GSW-2008MS

8x GbE, RJ45 + 2x Dual Rate SFP
L2+ Managed Switch with Cable Tray

GSW-2008MS is a managed Gigabit Ethernet CPE switch positioned as a layer 2 managed switch solution for high speed connectivity with popular traffic priority and management capabilities for small and medium businesses. It features 8-port 10/100/1000Base-T RJ45 and 2-100/1000Base-X SFP based fiber optics. The GSW-2008MS is designed with a high-performance switching architecture and offers wire-speed transportation capability for bandwidth-intensive applications of enterprises. More and more corporations are adapting new IT technologies over the network such as voice over IP, video conference to improve productivity and save operation expenditure. The GSW-2008MS also supports features such as VLAN, QoS, IGMP for multicast applications and network management to fulfill SMB requirements. The GSW2008 delivers a cost effective Gigabit Ethernet solution to meet the converged applications for enterprise customer's networks.

Feature

- 8-port 10/100/1000Base-T RJ45 + 2 uplink 100/1000Base-X SFP slot
- Supports 9K Bytes jumbo frame
- Supports IEEE 802.1Q tagged VLAN & Q-in-Q VLAN stacking
- Supports IEEE 802.1p priority queue
- Supports IGMP snooping v1/v2/v3
- Supports dying gasp
- Fiber Cable Tray (optional)

Specifications

Interface	8x 10/100/1000Base-T(X) RJ-45 with 2x 100/1000Base-X SFP
Filter & Forward rate	14880pps at 10Mbps, 148800pps at 100Mbps, 1488000pps at 1Gbps
Switching Fabric capacity	20Gbps
Transmission method	Store and Forward Switching
Standard	IEEE 802.3u, IEEE 802.3z, IEEE 802.3ae, IEEE 802.3x, IEEE 802.1p, IEEE 802.1Q, IEEE 802.1ad, IEEE 802.1x, IEEE 802.1D, IEEE 802.1w, IEEE 802.1s, IEEE 802.3ad, IEEE 802.1ab
Packet buffer	4M bits
MAC table size	8K
Jumbo frame size	9600 Bytes
VLAN feature	IEEE 802.1Q tagged VLAN (Max. 4K VLAN groups) MAC based VLAN Protocol based VLAN Private VLAN for port isolation IP subnet based VLAN, Voice VLAN VLAN translation, IEEE 802.1ad Q-in-Q
L2 switching protection	STP, RSTP, MSTP
Trunking	IEEE 802.3ad LACP
QoS feature	IEEE 802.1p 8 priority queues per port, Port Default Priority, User Priority, Input priority mapping, QoS Control List (QCL Mode), Storm Control for UC, BC and Unknown, Port policers, Global/VCAP (ACL) policers, Port egress shaper, Queue egress shapers, DiffServ (RFC2474) remarking, Tag remarking, Scheduler mode
Security	Port based/single/multiple IEEE 802.1x access control MAC based access control authentication RADIUS authentication, limited MAC address learning IP/MAC binding, ACL rule based filtering TACACS+, IP source guard DHCP snooping/relay option 82 ARP inspection

IP multicasting	IGMP throttling, IGMP filtering, IGMP fast leave, IGMP snooping v1/v2/v3, MVR, MLD snooping v1
Storm Control Management	Unicast/Broadcast/Multicast storm suppression Web/Telnet CLI interface, Web/CLI authentication, SSH v2, HTTPs, port mirroring, system syslog, IPv6 management, NTP, text based configuration upload or download, IEEE 802.1ab LLDP, Cisco discovery filtering (CDP), DHCP auto provisioning
SNMP agent	SNMP v1/v2c/v3, RMON Group 1,2,3 and 9
Software upgrade	TFTP/HTTP
Operating Temperature	0 ~ 50°C
Humidity	5% ~ 90% (non-condensing)
Dimensions	170 × 120 × 35mm (D x W x H)
Certification	FCC, CE

Application

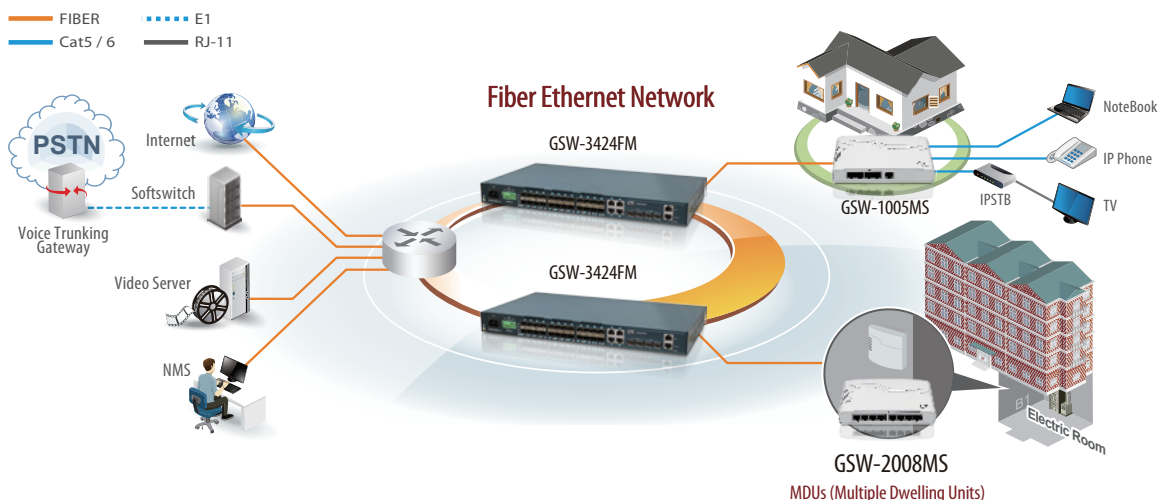

Cable Tray Assembly

CT001 is an optional fiber tray and mounting hardware for deploying GSW-1005/2008 for residential Fiber To The Home applications. CT002 is an optional accessory used when deploying GSW-1005/2008 in a public area. An added cover over UTP leads prevents unauthorized tampering of UTP connections. Both tray options are wall mounted, allowing secure termination of fiber leads.

CT001

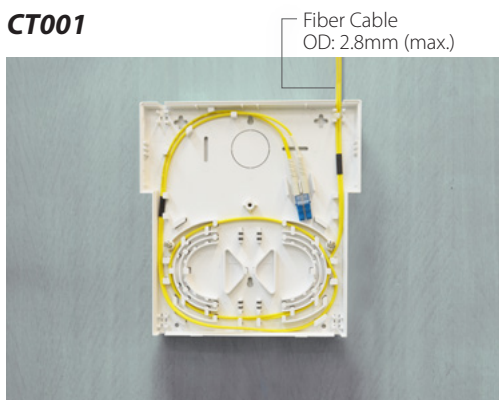

CT001 Cable Tray

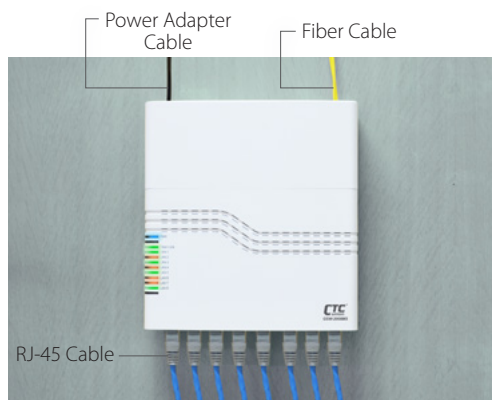

CT001 with GSW-2008MS

CT002

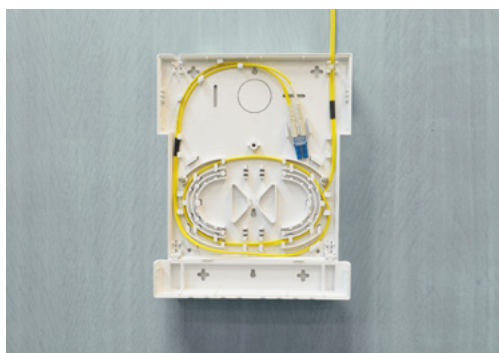

CT002 Cable Tray

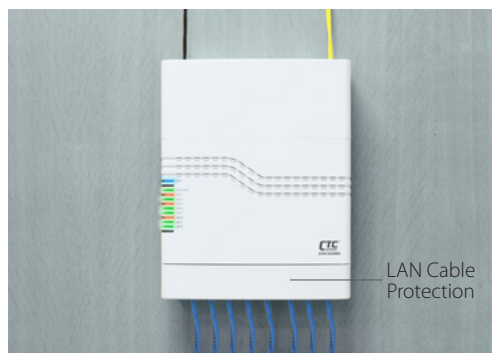

CT002 with GSW-2008MS

Ordering Information

Model Name	Description
GSW-2008MS	8-port 10/100/1000 Base-T to 2-port 100/1000 Base-X Managed GbE Switch (cable tray optional)

Optional Accessories

CT001	Cable Tray for GSW-1005MS/GSW-2008MS
CT002	Cable Tray & LAN cable protection cover for GSW-1005MS/2008MS

Dimensions (mm)

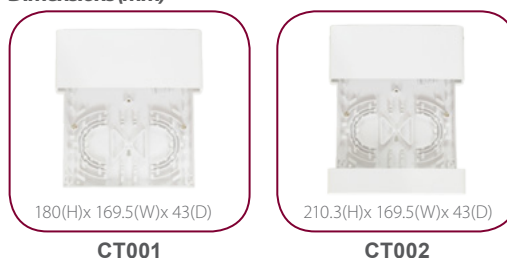



GSW-1005MS

5x GbE, RJ45 + 1x Dual Rate SFP
L2+ Managed Switch with Cable Tray

GSW-1005MS is a managed Gigabit Ethernet CPE switch designed 5-Ports 10/100/1000Base-T RJ45 and 1 port 100/1000Base-X SFP based fiber optics. The traditional transmission distance of Gigabit Ethernet over RJ45 copper can be extended up to 100km over a fiber optics interface. GSW-1005MS has a optional cable tray that allows the installer to enclose the excess fiber within the unit, thus providing protection for the sensitive fiber at subscriber side. LEDs provide visual monitoring of Ethernet connected devices such as Ethernet home gateways, wireless access points or PC/laptop via 10/100/1000Base-T twisted pair RJ45 ports on GSW-1005MS. When GSW-1005MS is deployed as a stand-alone solution, it incorporates an easy to use Web user interface for operation, administration and maintenance both locally and remotely. All of the enabled Layer 2 features and functions of GSW-1005MS can be configured and monitored via web, CLI or SNMP management. GSW- 1005MS is particularly suitable for deploying and provisioning active Ethernet FTTX service of multi-service operators (MSO).

Feature

- 5-Port 10/100/1000Base-T + 100/1000Base-X SFP uplink
- Supports 9.6K Bytes jumbo frame
- Supports IEEE 802.1Q tagged VLAN & Q-in-Q VLAN stacking
- Supports IEEE 802.1p priority queue
- Supports IGMP snooping v1/v2/v3
- Supports DHCP auto provisioning
- Supports dying gasp
- Fiber cable tray(optional)

Specifications

Interface	5x 10/100/1000Base-T(X) RJ-45 with 1x 100/1000Base-X SFP	Management	Web/Telnet CLI interface, Web/CLI authentication, SSH v2, HTTPs, port mirroring, system syslog, IPv6 management, NTP, text based configuration upload or download, IEEE 802.1ab LLDP, Cisco discovery filtering (CDP), DHCP auto provisioning
Switching fabric capacity	12Gbps	SNMP agent	SNMP v1/v2c/v3, RMON Group 1,2,3 and 9
Packet forwarding capacity	8.928Mpps	Software upgrade	TFTP/HTTP
Filter & Forward rate	14880pps at 10Mbps, 148800pps at 100Mbps, 1488000pps at 1Gbps	Power Input	100v~240VAC power adapter
Transmission method	Store and Forward Switching	Operating Temperature	0 ~ 50°C
Standard	IEEE 802.3u, IEEE 802.3z, IEEE 802.3ae, IEEE 802.3x, IEEE 802.1p, IEEE 802.1Q, IEEE 802.1ad, IEEE 802.1x, IEEE 802.1ab, IEEE 802.3az	Humidity	5% ~ 90% (non-condensing)
Packet buffer	4M bits	Dimensions	170 × 120 × 35mm (D x W x H)
MAC table size	8K	Certification	FCC, CE
Jumbo frame size	9600 Bytes		
VLAN feature	IEEE 802.1Q tagged VLAN (Max. 4K VLAN groups) MAC based VLAN Protocol based VLAN Private VLAN for port isolation IP subnet based VLAN, Voice VLAN VLAN translation, IEEE 802.1ad Q-in-Q		
QoS feature	IEEE 802.1p 8 priority queues per port, CoS based on switch port; VLAN ID; DSCP; TCP/UDP port IEEE 802.1p priority tag remarking, DSCP remarking, Port based ingress/egress rate limit		
Security	Port based/single/multiple IEEE 802.1x access control MAC based access control authentication RADIUS authentication, limited MAC address learning IP/MAC binding, ACL rule based filtering TACACS+, DHCP snooping/relay option 82 ARP inspection, IP source guard		
IP multicasting	IGMP throttling, IGMP filtering, IGMP fast leave, IGMP snooping v1/v2/v3, MVR, MLD snooping v1		
Storm Control	Unicast/Broadcast/Multicast storm suppression		

Application

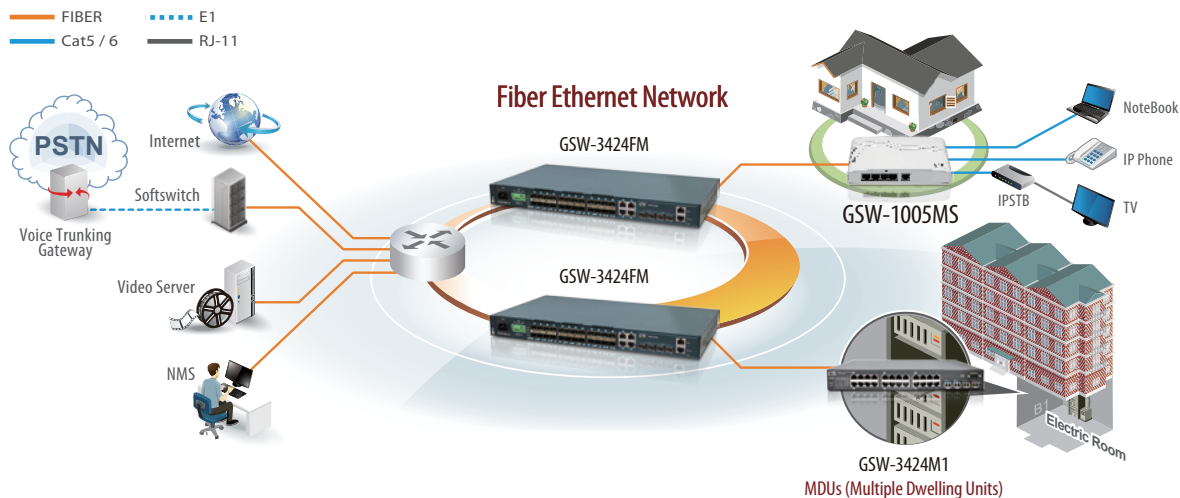

Cable Tray Assembly

CT001 is an optional fiber tray and mounting hardware for deploying GSW-1005/2008 for residential Fiber To The Home applications. CT002 is an optional accessory used when deploying GSW-1005/2008 in a public area. An added cover over UTP leads prevents unauthorized tampering of UTP connections. Both tray options are wall mounted, allowing secure termination of fiber leads.

CT001

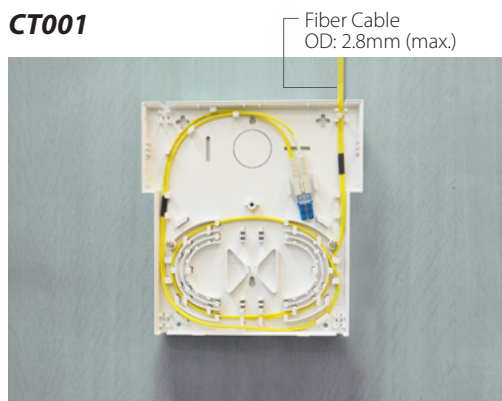

CT001 Cable Tray

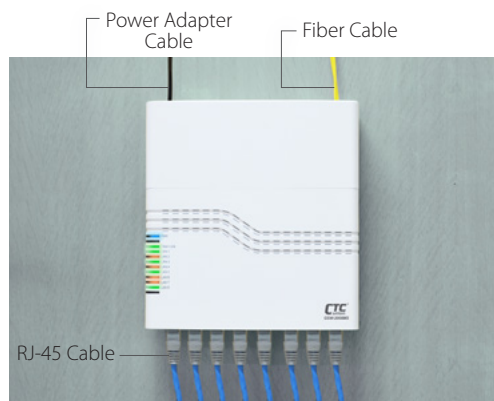

CT001 with GSW-2008MS

CT002

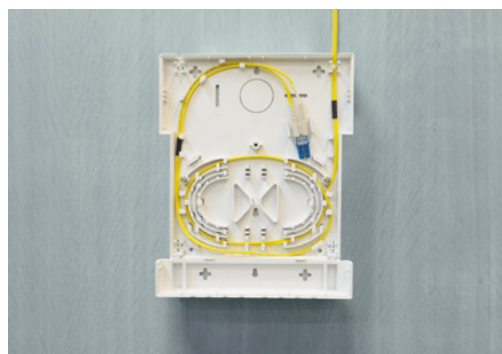

CT002 Cable Tray

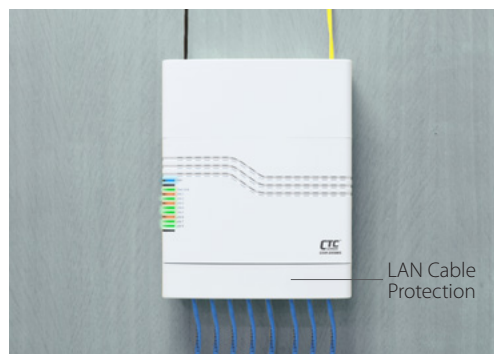

CT002 with GSW-2008MS

Ordering Information

Model Name	Description
GSW-1005MS	5-port 10/100/1000 Base-T to 100/1000 Base-X Managed GbE Ethernet Switch (cable tray optional)

Optional Accessories

CT001	Cable Tray for GSW-1005MS/GSW-2008MS
CT002	Cable Tray & LAN cable protection cover for GSW-1005MS/2008MS

Dimensions (mm)

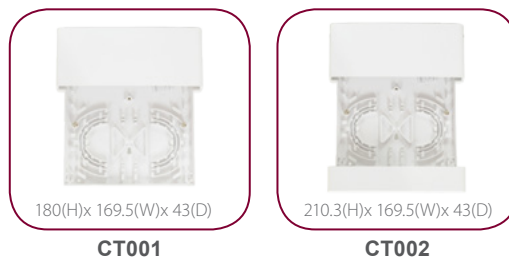



FSW-2104

4x 10/100Base-TX and 100Base-FX Switch with AC Power Adapter

The FSW-2104 provides a low cost solution for non-managed Ethernet fiber switches. The FSW-2104 is a 4-port 10/100Base-TX plus 1-port 100Base-FX Fast Ethernet switch with AC Power Adapter. FSW-2104 is designed for small workgroup applications that require a long distance connection to the backbone, such as between buildings, offices, or within a campus location. FSW-2104 provides full-duplex capability on each auto-negotiating port, for enhanced performance. A wide range of transceiver selection provides fiber connection with SC type connectors in multimode or single mode and at distance from 2 to 120km as well as BiDi (single fiber) at distances of 20, 40, 60, or 80km.

Feature

- 4x 10/100Base-TX and 1x 100Base-FX Switch
- Auto-Negotiation
- Auto MDI/MDIX
- Forward 1552 bytes (Max.) packets
- Supports 1K MAC address
- 512k bits packets buffer memory
- Supports broadcast storm protection

Specifications

Optical Interface	Connector	1x9 (SC)
	Data rate	100Mbps
	Duplex mode	Full duplex
	Fiber	MM 50/125µm, 62.5/125µm SM 9/125µm
	Distance	MM 2km, SM 15/30/50/80/120km WDM 20/40/60/80km
	Wavelength	MM 1310nm, SM 1310,1550nm WDM 1310Tx/1550Rx (type A) 1550Tx/1310Rx (type B)
Standards	IEEE802.3, IEEE802.3u	
Indications	LED (FX-Link, TX SPD, TX-Link/Act)	
Power Consumption	< 4W	

Dimensions	138 x 77 x 28mm (D x W x H) (FSW-2104)	
	215 x 91.3 x 29mm (D x W x H) (FSW-2104-AD)	
Weight	450g (FSW-2104), 550g (FSW-2104-AD)	
Electrical Interface	Connector	RJ-45
	Data rate	10Mbps, 100Mbps
	Duplex mode	Half / Full duplex
	Cable	10Base-T Cat.3, 4, 5, UTP, 100Base-TX Cat.5, 5e or higher
Power Input	AC	100~240VAC
	DC	18~60VDC
Temperature	0 ~ 50°C (Operating), 0 ~ 70°C (Storage)	
Humidity	10 ~ 90% non-condensing	
Certification	CE, FCC	
MTBF	65,000 hrs	

Application

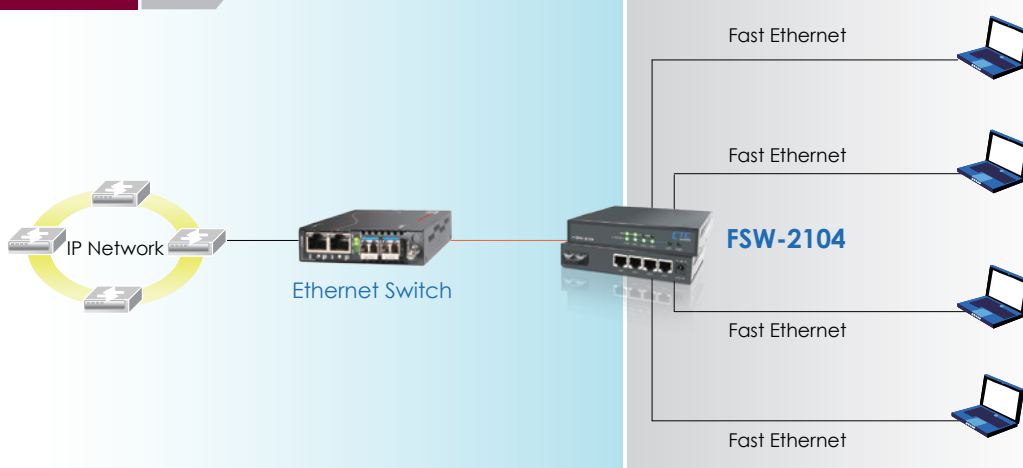

Ordering Information

Model Name	Description
FSW-2104-AD	4x 10/100Base-TX and 100Base-FX build-in AC+DC Power
FSW-2104	4x 10/100Base-TX and 100Base-FX Switch with AC Power Adapter
Connector Type	Connectivity Distance
SC	002: 2km 015: 15km 030: 30km 050: 50km 080: 80km 120: 120km 20A: WDM 20km A type 20B: WDM 20km B type 40A: WDM 40km A type 40B: WDM 40km B type 60A: WDM 60km A type 60B: WDM 60km B type 80A: WDM 80km A type 80B: WDM 80km B type

Connector Type Connectivity Distance
FSW - 2104 - □□□□ - AD
 Example: FSW - 2104 - SC002 - AD



GW-732FW

Gigabit Fiber IAD with IEEE 802.11ac WiFi

The GW-732FW is a new generation single mode Fiber and VoIP-based IAD (Internet Access Device), which is designed to interoperate with end-to-end fiber from major vendors to meet the worldwide market requirements of triple-play services. It is Class 1 laser product complying with EN 60825-1. The integrated Ethernet switch features automatic crossover-correction and auto-negotiation for easy connection to user's PCs or LAN environment. The GW-732FW model also features a built-in IEEE 802.11ac WiFi which brings relief to troublesome home network wirings. Two lines of telephony service are provided using VoIP technology with SIP signaling protocol.

Feature

Voice Features

- G.711 a/μ-law, G.729A/B, G.726, G.723.1
- DTMF Detection and Generation
- Silence Suppression & Detection
- Comfort Noise Generation (CNG)
- Voice Activity Detection (VAD)
- Echo Cancellation (G.165/G.168)
- Dynamic Jitter Buffer
- Call progress tone generation (FXS)
- Programmable Gain Control
- Inbuilt Local Mixer

SIP Method Support

- ACK, BYE, CANCEL, INFO, INVITE, MESSAGE, NOTIFY, OPTIONS, PING,
- PRACK, PUBLISH, REFER, REGISTER, SUBSCRIBE, UPDATE

SIP Call Features

- Peer to Peer Call
- Call Hold / Retrieve
- Call Waiting
- Call Pick Up
- Call Park / Retrieve (SIP Server Required)
- Call Forward - unconditional, busy, no answer
- Call Transfer - attended, unattended
- Do Not Disturb
- Speed Dialing
- Repeat Dialing
- Three-way Calling
- MWI (RFC-3842)
- Hot Line and Warm Line

IPTV Application

- IGMP Snooping
- Virtual LAN (VLAN)
- Quality of Service (QoS)

SIP Call Management

- Support Outbound Proxy
- SIP Registration Failover Mechanism
- Group Hunting
- Privacy Mechanism / Private Extensions to SIP
- Session Timers (Update / Re-invite)
- DNS SRV Support
- Call Types: Voice / Modem / FAX
- User Programmable Dial Plan Support
- Automatic Calling Number Manipulation
- CDR Client
- Manual Peer Table (for P2P calls)
- E.164 Numbering, ENUM support

SIP Account Management

- By port registration
- By device registration (share account)
- Mixed mode (Hunt number for inbound, by port number for outbound)
- Invite with Challenge
- Register by SIP Server IP Address or Domain Name
- Support RFC3986 SIP URI format

Telephony Specifications

- In-Band DTMF, Out-of-Band DTMF Relay (RFC2833 or SIP INFO)
- DTMF / PULSE Dial Support
- Caller ID Generation / Detection:
 - DTMF
 - FSK-Bellcore Type 1 & 2
 - FSK-ETSI Type 1 & 2
 - FSK-NTT
 - FSK: Calling Name, Number, Date and Time, vMWI
- FXS metering pulse:
 - Polarity Reversal
 - 12kHz calling tone
 - 16kHz calling tone
- Polarity Reversal Generation (FXS)
- T.30 FAX Bypass to G.711, T.38 Real Time FAX Relay
- ROH Tone (Receiver Off-Hook Tone @ 480 Hz)
- Loop Current Suppression

Wireless

- Compliant with IEEE802.11b/g/n/ac, 2.4G/5G concurrent operation
- Operating frequency 2.4 G/5 GHz
- Auto rate adaptive
- Multi-SSID
- Broadcast SSID control
- 64 / 128 bits WEP supported for encryption
- Wireless Security with WPA-PSK / WPA2-PSK
- WDS repeater function
- Wi-Fi Multi-Media (WMM) for AP mode
- WPS (Wi-Fi Protected Setup) for easy setup

Physical interface

- Combo WAN : GbE Ethernet copper or fiber SFP
- LAN : 4-Port RJ-45 10/100/1000 Ethernet
- Antenna : 2 x 2dBi detachable antenna
- Telephone: 2-port FXS
- Factory default reset button, WPS push button, Power jack, Power switch
- USB 2.0 Host interface x2

Fiber IAD

LED Indicators

- Power, Provision/Alarm, Register, WAN, WLAN, LAN1~LAN4, USB, Phone off-hook 1~2, WPS

Network Security Specifications

- DIGEST Authentication
- MD5 Encryption
- DoS Protection (configurable)
- Firewall: MAC filter, IP/Port filter, URL filter

Device Management

- WEB, TELNET
- TR-069, TR-098, TR-104, TR-111
- ACS info via DHCP options
- Two levels WEB login account
- WEB languages: English, TC
- System Information
- Per call RTP packet summary
- PING inquiry
- Syslog

Specifications

Protocol	SIP (RFC3261)
Model	2FXS
Combo WAN	GbE Ethernet copper or fiber (SFP)
LAN	4-port RJ-45 10/100/1000M Ethernet
Wi-Fi	IEEE 802.11b/g/n/ac, 2.4G/5G concurrent operation
Telephony Interface	RJ-11 connector
Power	AC 100~240V 50/60Hz input, DC 12V/2A output

Power Consumption	< 15W
Dimensions	155 x 226 x 80mm(D x W x H)
Weight	480g
Temperature	0 ~ 45°C (Operating), -25 ~ 75°C (Storage)
Humidity	Up to 90% RH, non-condensing
Certification	CE, FCC
MTBF	57,000 hours

Application

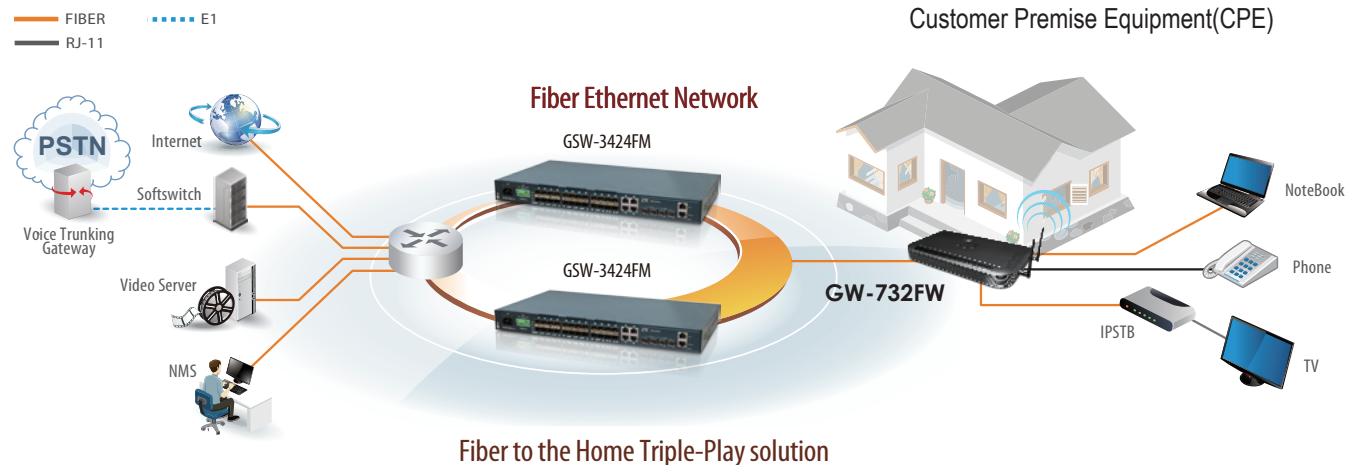

Ordering Information

Model Name	Description
GW-732FW	Fiber IAD Gateway with IEEE 802.11ac Wi-Fi



GW-532FW

Gigabit Fiber IAD with IEEE 802.11n WiFi

The GW-532FW is a single mode Fiber and VoIP-based IAD (Internet Access Device), which is designed to interoperate with end-to-end fiber from major vendors to meet the worldwide market requirements of triple-play services. It is Class 1 laser product complying with EN 60825-1. The integrated Ethernet switch features automatic crossover-correction and auto-negotiation for easy connection to user's PCs or LAN environment. The GW-532FW model also features a built-in 802.11n WiFi which brings relief to troublesome home network wirings. Two lines of telephony service are provided using VoIP technology with SIP and MGCP signaling protocol.

Feature

Voice Features

- G.722, G.711 a/μ-law, G.729A/B, G.726, G.723.1 GSM 6.10 Full Rate, iLBC 13.3 kbps
- DTMF Detection and Generation
- Silence Suppression & Detection
- Comfort Noise Generation (CNG)
- Voice Activity Detection (VAD)
- Echo Cancellation (G.165/G.168)
- Dynamic Jitter Buffer
- Call progress tone generation (FXS)
- Programmable Gain Control
- Inbuilt Local Mixer
- ITU-TV.152 Voice-band Data over IP Networks

SIP Method Support

- ACK, BYE, CANCEL, INFO, INVITE, MESSAGE, NOTIFY, OPTIONS, PING, PRACK, PUBLISH, REFER, REGISTER, SUBSCRIBE, UPDATE

SIP Call Features

- Peer to Peer Call
- Call Hold / Retrieve
- Call Waiting
- Call Pick Up
- Call Park / Retrieve (SIP Server Required)
- Call Forward - unconditional, busy, no answer
- Call Transfer - attended, unattended
- Do Not Disturb
- Speed Dialing
- Repeat Dialing
- Three-way Calling
- MWI (RFC-3842)
- Hot Line and Warm Line

IPTV Application

- IGMP Snooping
- Virtual LAN (VLAN)
- Quality of Service (QoS)

SIP Call Management

- Support Outbound Proxy
- SIP Registration Failover Mechanism
- Group Hunting
- Privacy Mechanism / Private Extensions to SIP
- Session Timers (Update / Re-invite)
- DNS SRV Support
- Call Types: Voice / Modem / FAX
- User Programmable Dial Plan Support
- Automatic Calling Number Manipulation
- CDR Client
- Manual Peer Table (for P2P calls)
- E.164 Numbering, ENUM support

SIP Account Management

- By port registration
- By device registration (share account)
- Mixed mode (Hunt number for inbound, by port number for outbound)
- Invite with Challenge
- Register by SIP Server IP Address or Domain Name
- Support RFC3986 SIP URI format

Telephony Specifications

- In-Band DTMF, Out-of-Band DTMF Relay (RFC2833 or SIP INFO)
- DTMF / PULSE Dial Support
- Caller ID Generation / Detection:
 - DTMF
 - FSK-Bellcore Type 1 & 2
 - FSK-ETSI Type 1 & 2
 - FSK-NTT
 - FSK: Calling Name, Number, Date and Time, vMWI
- FXS metering pulse:
 - Polarity Reversal
 - 12kHz calling tone
 - 16kHz calling tone
- Polarity Reversal Generation (FXS)
- T.30 FAX Bypass to G.711, T.38 Real Time FAX Relay
- ROH Tone (Receiver Off-Hook Tone @ 480 Hz)
- Loop Current Suppression

Wireless

- Compliant with IEEE802.11b/g/n, 2T2R
- Operating frequency 2.4GHz
- Auto rate adaptive
- Multi-SSID
- Broadcast SSID control
- 64 / 128 bits WEP supported for encryption
- Wireless Security with WPA-PSK / WPA2-PSK
- WDS repeater function
- Wi-Fi Multi-Media (WMM) for AP mode
- WPS (Wi-Fi Protected Setup) for easy setup

Physical interface

- Combo WAN : Gigabit Ethernet copper or fiber SFP
- LAN : 4-Port RJ-45 10/100/1000 Ethernet
- Antenna : 2 x 2dBi detachable antenna
- Telephone: 2-port FXS
- Factory default reset button, WPS push button, Power jack, Power switch
- USB 2.0 Host interface x 2

Fiber IAD

LED Indicators

- Power, Provision/Alarm, Register, WAN, WLAN, LAN1~LAN4, USB, Phone off-hook 1~2, WPS

Network Security Specifications

- DIGEST Authentication
- MD5 Encryption
- DoS Protection (configurable)
- Firewall: MAC filter, IP/Port filter, URL filter

Device Management

- WEB, TELNET
- TR-069, TR-098, TR-104, TR-111
- ACS info via DHCP options
- Two levels WEB login account
- WEB languages: English, TC
- System Information
- Per call RTP packet summary
- PING inquiry
- Syslog

Specifications

Protocol	SIP (RFC3261)
Model	2FXS
Combo WAN	Gigabit Ethernet copper or fiber (SFP)
LAN	4-port RJ-45 10/100/1000 Ethernet
Wi-Fi	IEEE 802.11b/g/n, 2T2R
Telephony Interface	RJ-11 connector
Power	AC 100~240V 50/60Hz input, DC 12V/2A output

Power Consumption	< 15W
Dimensions	155 x 226 x 80mm(D x W x H)
Weight	480g
Temperature	0 ~ 45°C (Operating), -25 ~ 75°C (Storage)
Humidity	Up to 90% RH, non-condensing
Certification	CE, FCC
MTBF	57,000 hours

Application

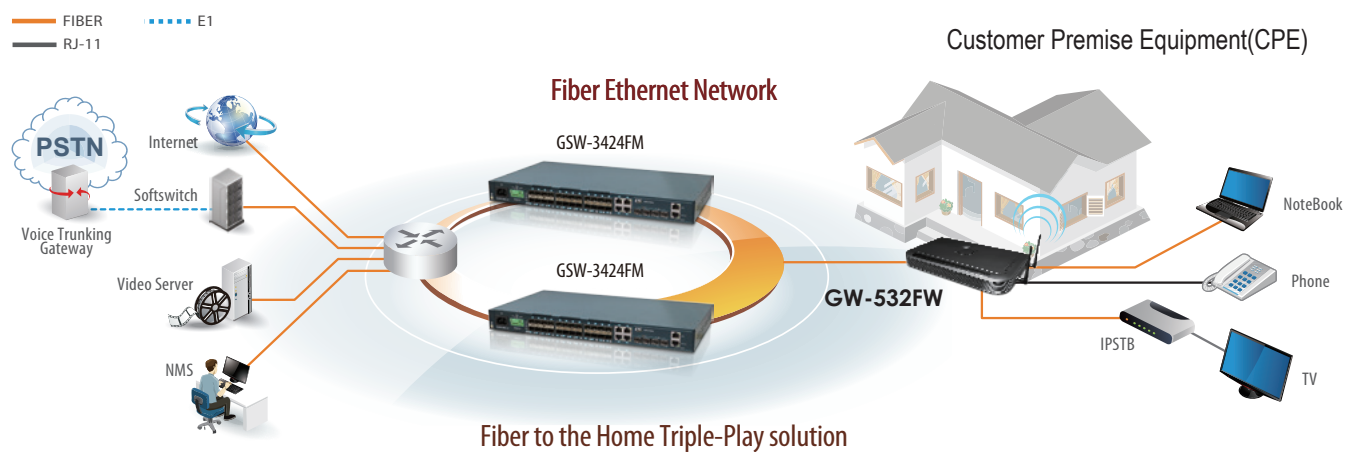

Ordering Information

Model Name	Description
GW-532FW	Fiber IAD Gateway with IEEE 802.11 n Wi-Fi



GSW-3216MP

16x GbE, RJ45 + 2 Dual Rate SFP
L2+ Managed PoE Switch

5

PoE Switch

The GSW-3216MP is a cost-effect high performance Gigabit L2 PoE+ switch with 16x 10/100/1000Mbps TX ports and 2x SFP ports. This switch supports remote management by SNMP, Http/Https or Telnet/SSH, and local management by console interface. Console interface is supported for some basic settings using CLI commands. The GSW-3216MP supports many L2 switch functions, e.g. 802.1Q VLAN, 802.1x Port Security, Rate Control, Port Configuration, Port Mirroring, Port Statistics, QoS functions, etc. Auto-MDIX function is supported for every TX port of the switch for easy cable connection. The GSW-3216MP is compliant with IEEE802.3af and 802.3at. The 16x 10/100/1000Mbps TX ports are selectable to provide up to 15.4 or 30 watts power to connect PoE supported devices.

Feature

- 16x RJ45 ports, with 10/100/1000Mbps
- 2x Dual Speed SFP sockets, Port17 and Port18
- Port 1 ~ Port 16 support PSE function
- IPv6 management
- 8 priority queues are supported on each port for QoS application
- Private VLAN, 802.1Q VLAN, Voice VLAN and Q-in-Q(double tagging) function
- Protected port and LoopBack Detection function
- IEEE 802.1x security function, and VLAN assignment, Guest VLAN functions
- Static Mac address access limit and Dynamic Mac address number on port
- IEEE802.1d & 802.1w & 802.1s
- IP Multicast with IGMP snooping / query / fast leave / filtering / group limited /MVR
- DHCP Client / DHCP Option 82 Relay / DHCP Snooping function
- ACL function for L2 ~ L4 packet control
- Ingress/Egress rate control on port
- Broadcast/Multicast/Unicast storm control
- ARP inspection / IP source guard
- RMON 1,2,3,9
- SFP Transceiver DDMI function / Dual Speed SFP Ports(100/1000Mbps)
- Remote port configuration setting and statistics monitoring
- Text configuration download and upload
- IEEE 802.3az power management

Specifications

System	
10/100/1000 BASE-T	16
100/1G SFP Slot	2 (Port 17, Port 18)
CPU	416MHz MIPS 24KEc CPU as the main processor which integrated on switch controller
Memory	Flash : SPI 16MB / RAM:DDRII 128MB
Packet buffer	4M bits
MAC Table size	8K
Filter & forward rate	14880pps at 10Mbps, 148800pps at 100Mbps, 1488000pps at 1Gbps
Switching Fabric capacity	36Gbps
PoE Standard	IEEE802.3af & IEEE802.3at
PoE Ports	16 Ports(Port 1 ~ Port 16) Per Port 56V DC, 350mA . Max. 15.4Watts Per Port 56V DC, 600mA . Max. 30Watts
PoE Power Budget	150Watts
Power PIN Assignment	1/2(-), 3/6(+)
Console port	D-Sub 9
19" Rack-Mount	Yes, with kits
SFP DDMI	Yes
Dimension	330mm x 204mm x 44mm
Environmental Temperature	Operating: 0 ~ 50°C / Storage: -25 ~ 70°C
Humidity	10% ~ 90% (non-condensing)
LED Display	Per Port : Link/Act , PoE Act Per Device : Power, System
Power Input	AC Power input (100V~240V)

Software	
Port Control	Port speed, duplex mode, and flow control Port Auto MDI/MDI-X Port frame size (jumbo frames), Maximum ingress frame size (10056 bytes) Port state (administrative status) Port status (link monitoring) Port statistics (MIB counters)
L2 Switching	Auto MAC address learning/aging and MAC addresses (static) DHCP snooping ARP inspection Port Mirroring Flow mirroring
L3 Switching	DHCP option 82 relay IPv4 Unicast: Static routing
VLANs	IEEE 802.1Q static VLAN(4096 entries Max.), Voice VLAN, Port isolation, Private VLAN Static, MAC based VLAN, Protocol based VLAN, IP subnet based VLAN, GVRP
Spanning Tree	IEEE 802.1s MSTP(Multiple spanning tree) IEEE 802.1w RSTP(Rapid spanning tree) IEEE 802.1D STP(Spanning tree) BPDU Guard & Restricted Role
Link Aggregation	Static and LACP
IP Multicast	IGMP v2 and v3 snooping MLD v1 snooping IGMP filtering profile IPMC throttling, filtering, leave proxy MVR and MVR profile

PoE Switch

QoS	Traffic Classes (8 active priorities) Port Default Priority, User Priority, Input priority mapping QoS Control List (QCL Mode) Storm Control for UC, BC and Unknown Port policers Global/VCAP (ACL) policers Port egress shaper Queue egress shapers DiffServ (RFC2474) remarking Tag remarking Scheduler mode
Security	Port-Based 802.1X, Single 802.1X, Multiple 802.1X, MAC-Based Authentication VLAN Assignment , QoS Assignment, Guest VLAN RADIUS Accounting MAC Address Limit IP MAC binding, IP/MAC binding dynamic to static TACACS+ Web & CLI Authentication Authorization (15 user levels) ACLs for filtering/policing/port copy IP source guard

Synchronization	NTPv4 Client
SFP DDMI	Yes
Management	DHCP Client, DNS client, proxy HTTP Server CLI - Console Port & Telnet Text Configuration download or upload Management access filtering HTTPS SSHv2 IPv6 Management System Syslog Software Upload via web SNMP v1 / v2c / v3 Agent RMON (Group 1, 2, 3 & 9) RMON alarm and event(CLI,web) SNMP multiple trap destinations IEEE 802.1AB-2005 Link Layer Discovery LLDP Cisco Discovery filtering - CDP sFlow Daylight Saving

Application

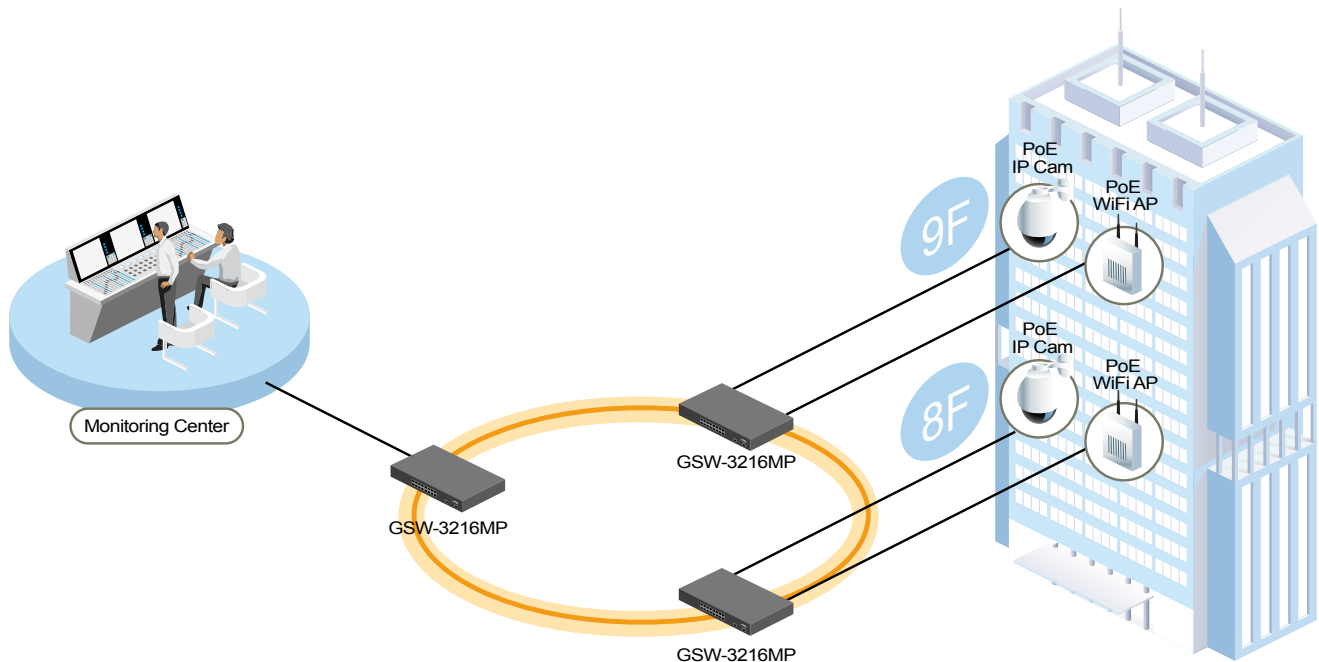

Ordering Information

Model Name	Description
GSW-3216MP	16 ports 10/100/1000Base-TX + 2 ports GbE SFP slot L2+ Managed PoE Switch



GSW-3208MP

8x GbE, RJ45 + 2 Dual Rate SFP
L2+ Managed PoE Switch

5

PoE Switch

The GSW-3208MP is a cost-effect high performance Gigabit L2 PoE+ switch with 8x10/100/1000Mbps TX ports and 2x SFP ports. This switch supports remote management by SNMP, Http/Https or Telnet/SSH, and local management by console interface. Console interface is supported for some basic settings using CLI commands. The GSW-3208MP supports many of L2 switch functions, e.g. 802.1Q VLAN, 802.1x Port Security, Rate Control, Port Configuration, Port Mirroring, Port Statistics, QoS functions, etc. Auto-MDIX function is supported for every TX port of the switch for easy cable connection. The GSW-3208MP is compliant with IEEE802.3af and 802.3at. The 8x10/100/1000Mbps TX ports are selectable to provide up to 15.4 or 30 watts power to connect PoE supported devices.

Feature

- 8x RJ45 ports, with 10/100/1000Mbps
- 2x Dual Speed SFP sockets, Port 9 and Port 10
- Port 1 ~ Port 8 support PSE function
- IPv6 management
- 8 priority queues are supported on each port for QoS application
- Private VLAN, 802.1Q VLAN, Voice VLAN and Q-in-Q(double tagging) function
- Protected port and LoopBack Detection function
- IEEE 802.1x security function, and VLAN assignment, Guest VLAN functions
- Static Mac address access limit and Dynamic Mac address number on port
- IEEE802.1d & 802.1w & 802.1s
- IP Multicast with IGMP snooping / query / fast leave / filtering / group limited /MVR
- DHCP Client / DHCP Option 82 Relay / DHCP Snooping function
- ACL function for L2 ~ L4 packet control
- Ingress/Egress rate control on port
- Broadcast/Multicast/Unicast storm control
- ARP inspection / IP source guard
- RMON 1,2,3,9
- SFP Transceiver DDMI function / Dual Speed SFP Ports(100/1000Mbps)
- Remote port configuration setting and statistics monitoring
- Text configuration download and upload
- IEEE 802.3az power management

Specifications

System	
10/100/1000 BASE-T	8
100/1G SFP Slot	2 (Port 9, Port 10)
CPU	416MHz MIPS 24KEc CPU as the main processor which integrated on switch controller
Memory	Flash : SPI 16MB / RAM:DDRII 128MB
Packet buffer	4M bits
MAC Table size	8K
Filter & forward rate	14880pps at 10Mbps, 148800pps at 100Mbps, 1488000pps at 1Gbps
Switching Fabric capacity	20Gbps
PoE Standard	IEEE802.3af & IEEE802.3at
PoE Ports	16 Ports(Port 1 ~ Port 16) Per Port 56V DC, 350mA . Max. 15.4Watts Per Port 56V DC, 600mA . Max. 30Watts
PoE Power Budget	150Watts
Power PIN Assignment	1/2(-), 3/6(+)
Console port	D-Sub 9
19" Rack-Mount	Yes, with kits
SFP DDMI	Yes
Dimension	330mm x 204mm x 44mm
Environmental Temperature	Operating: 0 ~ 50°C / Storage: -25 ~ 70°C
Humidity	10% ~ 90% (non-condensing)
LED Display	Per Port : Link/Act , PoE Act Per Device : Power, System
Power Input	AC Power input (100V~240V)

Software	
Port Control	Port speed, duplex mode, and flow control Port Auto MDI/MDI-X Port frame size (jumbo frames), Maximum ingress frame size (10056 bytes) Port state (administrative status) Port status (link monitoring) Port statistics (MIB counters)
L2 Switching	Auto MAC address learning/aging and MAC addresses (static) DHCP snooping ARP inspection Port Mirroring Flow mirroring
L3 Switching	DHCP option 82 relay IPv4 Unicast: Static routing
VLANs	IEEE 802.1Q static VLAN(4096 entries Max.), Voice VLAN, Port isolation, Private VLAN Static, MAC based VLAN, Protocol based VLAN, IP subnet based VLAN, GVRP
Spanning Tree	IEEE 802.1s MSTP(Multiple spanning tree) IEEE 802.1w RSTP(Rapid spanning tree) IEEE 802.1D STP(Spanning tree) BPDU Guard & Restricted Role
Link Aggregation	Static and LACP
IP Multicast	IGMP v2 and v3 snooping MLD v1 snooping IGMP filtering profile IPMC throttling, filtering, leave proxy MVR and MVR profile

PoE Switch

QoS	Traffic Classes (8 active priorities) Port Default Priority, User Priority, Input priority mapping QoS Control List (QCL Mode) Storm Control for UC, BC and Unknown Port policers Global/VCAP (ACL) policers Port egress shaper Queue egress shapers DiffServ (RFC2474) remarking Tag remarking Scheduler mode
Security	Port-Based 802.1X, Single 802.1X, Multiple 802.1X, MAC-Based Authentication VLAN Assignment , QoS Assignment, Guest VLAN RADIUS Accounting MAC Address Limit IP MAC binding, IP/MAC binding dynamic to static TACACS+ Web & CLI Authentication Authorization (15 user levels) ACLs for filtering/policing/port copy IP source guard

Synchronization	NTPv4 Client
SFP DDMI	Yes
Management	DHCP Client, DNS client, proxy HTTP Server CLI - Console Port & Telnet Text Configuration download or upload Management access filtering HTTPS SSHv2 IPv6 Management System Syslog Software Upload via web SNMP v1 / v2c / v3 Agent RMON (Group 1, 2, 3 & 9) RMON alarm and event(CLI,web) SNMP multiple trap destinations IEEE 802.1AB-2005 Link Layer Discovery LLDP Cisco Discovery filtering - CDP sFlow Daylight Saving

Application

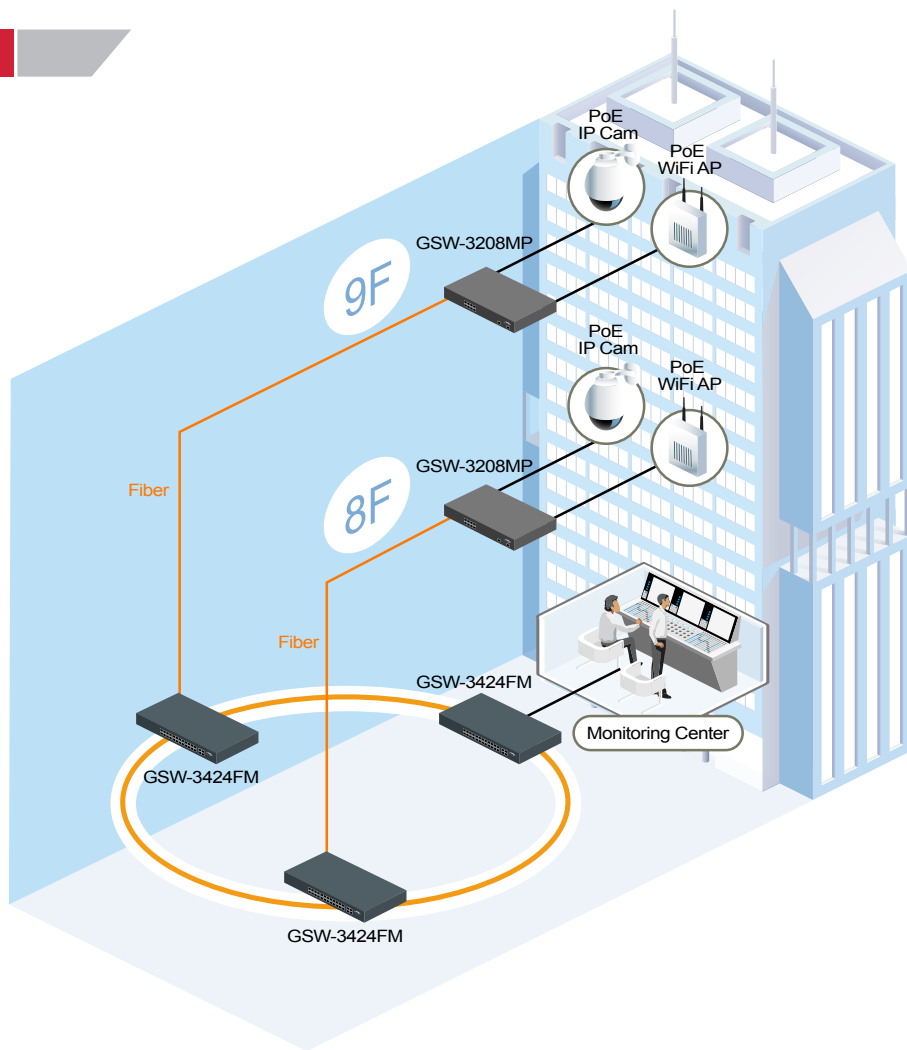

Ordering Information

Model Name	Description
GSW-3208MP	8 ports 10/100/1000Base-TX + 2 ports GbE SFP slot L2+ Managed PoE Switch



FMC-1000S-PH

10/100/1000Base-T to 100/1000Base-X SFP with PoE+ (PSE) Fiber Converter

FMC-1000S-PH is an unmanaged Gigabit Ethernet media converters that support conversion between electrical 10/100/1000Base-T and optical 1000Base-X Ethernet and as PSE (Power Source Equipment) provide PoE+ power over Ethernet. FMC-1000S-PH provides an SFP cage for 100/1000Base-X compatible SFP modules.

Feature

- Conversion between 10/100/1000Base-T and 100/1000Base-X
- Supports dual rate (100/1000) SFP for selectable Fast or Gigabit speed on fiber
- PoE output voltage upto 55VDC
- Supports IEEE802.3at/af PoE , output 30Watts Power Budget
- Supports LFPT (Link Fault Pass Through)
- Supports DIP SW for setting LFPT,Switch or Converter mode,SFP speed
- Wall Mount and compact size for easy installation
- Supports Jumbo frame 9K bytes packet

Specifications

Standard	IEEE802.3 10Base-T IEEE802.3u 100Base-T(X) IEEE802.3u 100Base-FX IEEE802.3ab 1000Base-T(X) IEEE802.3z 1000Base-SX/LX IEEE802.3x Flow Control and Back pressure IEEE802.3at Power over Ethernet + PoE+ IEEE802.3af Power over Ethernet, PoE	LED	Per Unit: Power (Green) Fiber LNK/ACT (Green): RJ-45 port: 100LK/Act (Green) 1000LK/Act (Green) Dup/Col (Green) PoE Status (Green): Flash: PoE Fault (Over-load or short), On: PoE normal working Off: PoE No Power output
RJ45 Ports	10/100/1000Base-T	Power Input	48V~57VDC Input (Ship with 56VDC Power Adapter)
Fiber Ports	100/1000Base-X SFP	Power Apapter	Input 100/110/120/220/240 VAC (Wide Range) Output 36W, 56VDC
Data process Architecture	Store and Forward mode or Pass through mode set by DIP SW	PoE output voltage	55VDC
Jumbo Frame	9K bytes	PoE Power Budget	30W (Maximum)
Fiber parameters	Fiber Cable (Multi-mode): 50/125um,62.5/125um Fiber Cable (Single-mode):9/125um Wavelength: 1310nm (Multi-mode/Single-mode) Available distance: 500M (Multi-mode SX) 20KM (Single-mode) 40KM (Single-mode) SFP, Distance depend on plug-in Fiber Transceiver	Power Consumption	Maximum 35.4W (include PoE power budget 30W)
Link Fault Pass through (LFPT)	TX-- Fiber: If TX port link down, the media converter will force Fiber port to link down Fiber--TX: If Fiber port link down, the media converter will force TX port to link down	Operating Humidity	10 ~ 90% non-condensing
DIP Switch	Off : LFPT Disable On: LFPT Enable Data process Architecture Off : Store and Forward Switch mode On : Pass through mode Fiber Mode: Off: Auto On:Force SFP Fiber Speed Off: 1000BaseX On: 100Base X	Operating Temperature	0°C ~ 50°C
Connector and Pin assignment	SFP Slot RJ-45 Socket: CAT-3/5 (10/100Mbps) Twisted Pair cable Auto MDI/MDI-X and Auto-Negotiation Function Support RJ-45 port support IEEE 802.3at/af End-Span, Alternative A mode. Positive (V+): RJ-45 pin 1, 2. Negative (V-): RJ-45 pin 3, 6. Data : 1,2,3,6,4,5,7,8	Storage Temperature	-40°C ~ 85°C
		Housing	Plastic
		Dimension	108 x 23 x 74mm (D x W x H)
		Weight	80g
		Installation	Desk top or Wall Mounting (Optional)
		EMC	FCC Class A, CE
		MTBF	749556

Application

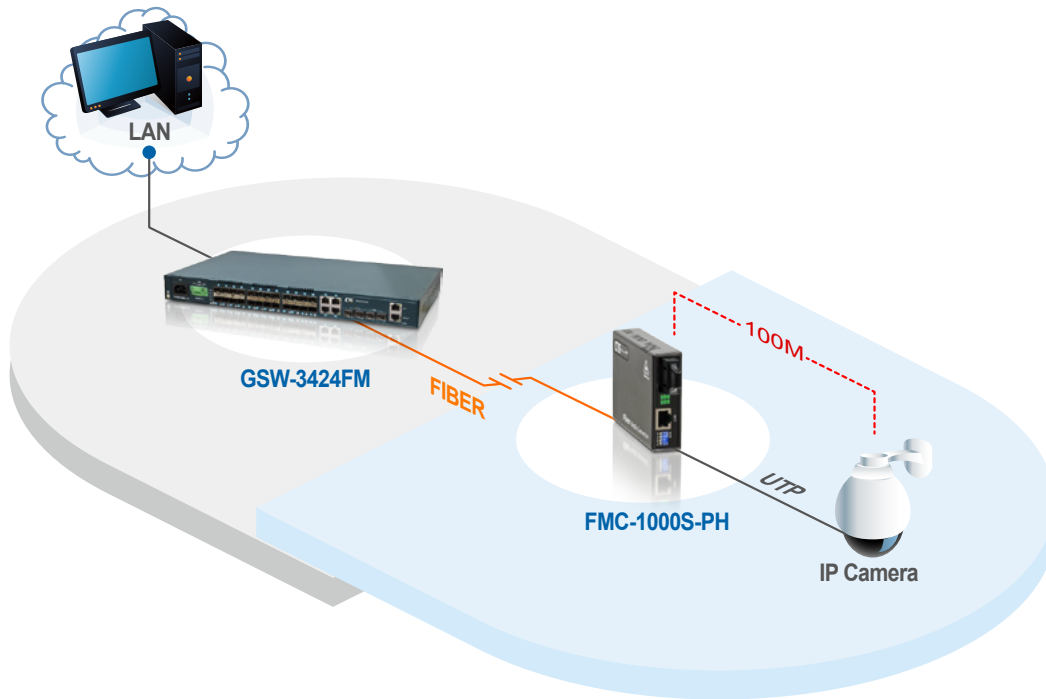

Ordering Information

Model Name	Description
FMC-1000S-PH	10/100/1000Base-T to 100/1000Base-X SFP With PoE+ (PSE) Fiber Converter (30W)
FMC-1000S-PH-WM	10/100/1000Base-T to 100/1000Base-X SFP With PoE+ (PSE) Fiber Converter (30W) with wall mount kit

FMC - 1000S-PH- ^{Wall-Mount Kits} - ^{Connect Type}
 Example: FMC - 1000S-PH- WM - SC002



Wall-Mount Type



Non Wall-Mount Type



IFC-1000PSE IFC-1000PSE/A

100/1000Base-T to 1000Base-X SFP PoE PSE Converter with AC Power built-in & AC Adapter

The IFC-1000PSE/A is a copper to fiber Gigabit Ethernet solution designed to make conversion between 10/100/1000Base-T to 1000Base-SX/LX with SFP LC connector. The IFC-1000PSE complies with IEEE802.3af Power Over Ethernet standard with external AC power adapter or internal AC power build-in. This PoE media converter is a Power Sourcing Equipment (PSE) which combines data received over a TP link with 48VDC power, providing power to IEEE802.3af powered device (PD) over the existing CAT5 UTP cable. Other features include Link fault Pass-Through (LFPT), Store and Forward Switching, auto or forced mode setting for copper Ethernet as well as auto laser shutdown.

Feature

- 10/100/1000Base-T to 1000Base-SX/LX SFP
- IEEE 802.3af Compliant PSE (power sourcing equipment)
- Auto-negotiation or forced mode
- Auto MDI/MDIX
- Store and Forward Switching Mechanism
- Supports 4K MAC address
- Supports 256K Byte Packet Buffer
- Forward 1632 bytes (max.) packets
- Supports Link fault Pass-Through (LFPT) function

Specifications

Optical Interface	Connector	SFP LC
	Data rate	1250Mbps
	Duplex mode	Full duplex
	Fiber	MM 50/125µm, 62.5/125µm. SM 9/125µm
	Distance	MM 550m, 2km, SM 15/30/50/80/120km WDM 20/40/60km
	Wavelength	MM 1310nm, SM 1310,1550nm WDM 1310Tx/1550Rx (type A) 1550Tx/1310Rx (type B)
Electrical Interface	Connector	RJ-45
	Data rate	10Mbps, 100Mbps, 1000Mbps
	Duplex mode	Half / Full duplex
	Cable	10Base-T Cat 3, 4, 5, UTP 100Base-TX Cat 5, 5e or higher 1000Base-T Cat 5, 5e or higher

PSE Output Power	Class 0:	15.4w	Class 1:	4w
	Class 2:	7w	Class 3:	15.4w
Standards	IEEE 802.3, 802.3u, 802.3ab, 802.3z, 802.3af, 802.3x			
Indications	LED (Power, FX-Link, FX Duplex, TX-SPD, TX-Duplex, TX-Link)			
Power Input	100 ~ 240VAC			
Power Consumption	< 5W (w/o PSE Output Power)			
Dimensions	201 x 135 x 35mm (D x W x H)			
Weight	0.58kg			
Temperature	0 ~ 50°C (Operating), -10 ~ 70°C (Storage)			
Humidity	10 ~ 90% non-condensing			
Certification	CE, FCC			
MTBF	75,000 hrs			

Application

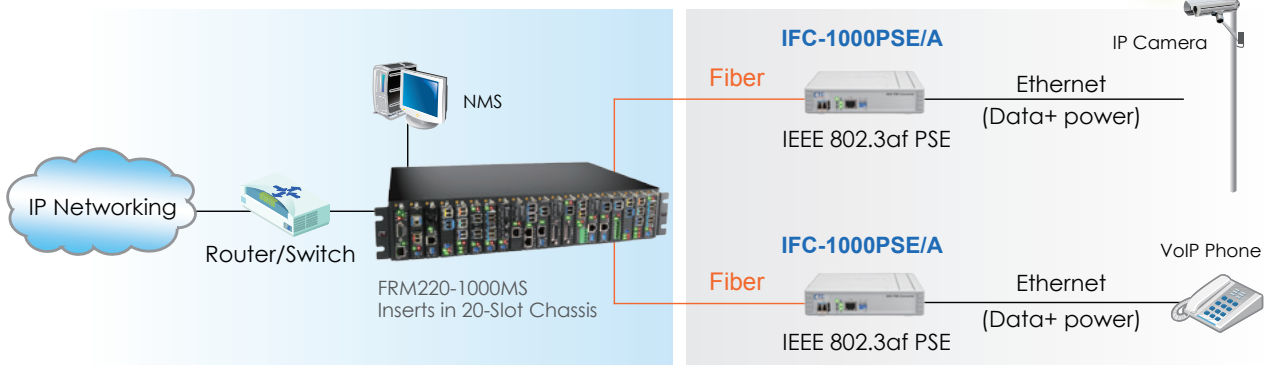

Ordering Information

Model Name	Description
IFC-1000PSE/A	GE PoE PSE media converter with DC 48V in AC adapter
IFC-1000PSE-AC	GE PoE PSE media converter with built-in AC power 100 ~240V

Interface Power Type
IFC - □□□□□□□□ - □□
 Example: IFC - 1000PSE- AC



IFC-100PD

10/100Base-TX to 100Base-FX PoE PD Media Converter

The IFC-100PD is Power over Ethernet 10/100Base-TX to 100Base-FX non-managed PD(Power Device) Fiber converter, which give you the options to choose from the most popular fiber cabling connectors, ST, SC, FC. Both multi-mode and single mode converter models are available as well as BiDi which allows bi-directional transmissions using only a single fiber cable. With Power over Ethernet (PoE) feature, IFC-100PD takes power supply over Ethernet cable from PoE Ethernet Switch and may work without external power adapter. When auto-negotiation is selected, these units will automatically tailor themselves to convert both half-duplex and full-duplex signals, according to IEEE802.3u standards. LED indicators signal the power status of the converter, UTP port speed, Link, and duplex status, FX port Link and duplex status. The stand-alone converter may also be concentrated into either the FMC-CH08 or FMC-CH17 non-managed chassis.

Feature

- 10/100Base-TX to 100Base-FX Converter
- Auto-Negotiation or forced mode
- Auto MDI/MDIX
- Forward 1600 bytes (Max.) packets
- Supports Q in Q double tagged frame transparent
- Supports IEEE 802.1Q Tag VLAN pass thru
- Supports flow control (Pause)
- Supports Link Fault Pass-Through (LFPT)
- Forward 9K jumbo packets in converter mode
- Supports IEEE802.3af Power over Ethernet

Specifications

Optical Interface	Connector	1x9 (SC, ST, FC)	Standards	IEEE 802.3, IEEE 802.3u, IEEE 802.3af	
	Data rate	125Mbps		Indications	LED (Power, FX Link, TX SPD, TX Link, TX Duplex, FEF)
	Duplex mode	Full duplex			Power Input
	Fiber	MM 50/125µm, 62.5/125µm SM 9/125µm		Power Consumption	
	Distance	MM 2km, SM 15/30/50/80/120km WDM 20/40/60/80km			Dimensions
	Wavelength	WDM 1310Tx/1550Rx (type A) 1550Tx/1310Rx (type B) 1550Tx/1310Rx (type B)		Weight	
	Electrical Interface	Connector			RJ-45
Data rate		10Mbps, 100Mbps	Humidity	10 ~ 90% non-condensing	
Duplex mode		Half / Full duplex		Certification	CE, FCC
Cable		10Base-T Cat.3, 4, 5, UTP, 100Base-TX Cat.5, 5e or higher 1000Base-T Cat 5, 5e or higher	MTBF		65,000 hrs
PD Input Power		48VDC			

Application

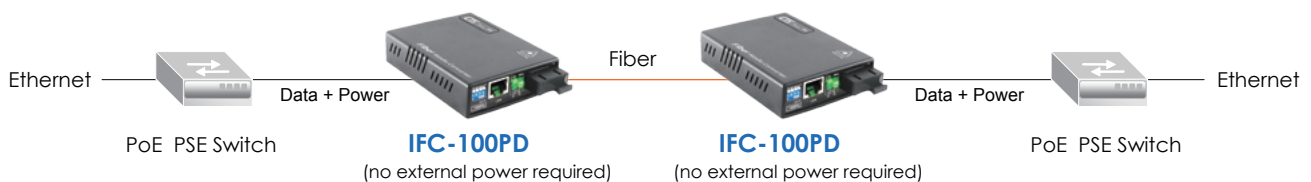

Ordering Information

Model Name	Description
IFC-100PD	10/100Base-TX to 100Base-FX PoE PD media converter
Connector Type	Connectivity Distance
SC, ST, FC	002: 2km 015: 15km 030: 30km 050: 50km 20A: WDM 20km A type 20B: WDM 20km B type 40A: WDM 40km A type 40B: WDM 40km B type

Connector Type Connectivity Distance
IFC - 100PD - □□□□□□
 Example: IFC - 100PD - SC002



INJ-G30

Gigabit Ethernet IEEE802.3af/at High Power PoE Injector

This device consists of 1 PoE Injector ports. That can solve the limitation of the power outlet location and offer the system designer a flexible solution to locate the network device everywhere. The compact size and wall mounting was specifically designed for easy installation. It can be installed where space is limited; moreover, it provides smooth network migration and easy upgrade to network capacity.

Feature

- 1 Port PoE Injector, 55VDC /30W output
- Compliant IEEE802.3af/at
- Providing 1 10/100/1000Mbps pass through data rate
- Wall Mountable
- Compliant with IEEE 802.3 10Base-T, IEEE 802.3u 100Base-TX and IEEE802.3ab 1000Base-T
- Safety & EMI Certificates: CE & FCC Class B Smart plug & play
- Compact Size

Specifications

Ethernet Standard	IEEE 802.3 10Base-T 10Mbit/s Ethernet	External Power Adapter	Input 100/110/120/220/240 VAC (Wide Range)
	IEEE 802.3u 100Base-TX, 100Base-FX, Fast Ethernet		Output 36W ,56VDC
	IEEE 802.3ab 1000Base-T Gbit/s Ethernet over twisted pair	PoE output voltage	55VDC
Network Cable	IEEE 802.3af Power over Ethernet (PoE)	PoE Power Budget	30W (Maximum)
	IEEE 802.3at Power over Ethernet (PoE+)	Operating Temperature	0 ~ 45°C
Indications	1x RJ-45 for 10/100/1000Base-T data	Storage Temperature	-20 ~ 85°C
	1x RJ-45 for 10/100/1000Base-T data and PoE Power output	Humidity	10 ~90% RH (Non-condensing)
Power Input	10Base-T Cat. 3, 4, 5e UTP/STP;	Dimension	80 x 68 x 24mm (D x W x H)
	100/1000Base-T Cat. 5 UTP/STP	Weight	138g
Filtering/ Forwarding Rate	10/100/1000Mbps pass through data rate	Installation mounting	Wall mount
PoE Power output pin	RJ45 Pin 1,2(V+), Pin 3,6(V-)	Certificates	CE & FCC Class B
LED	System Power		

Application

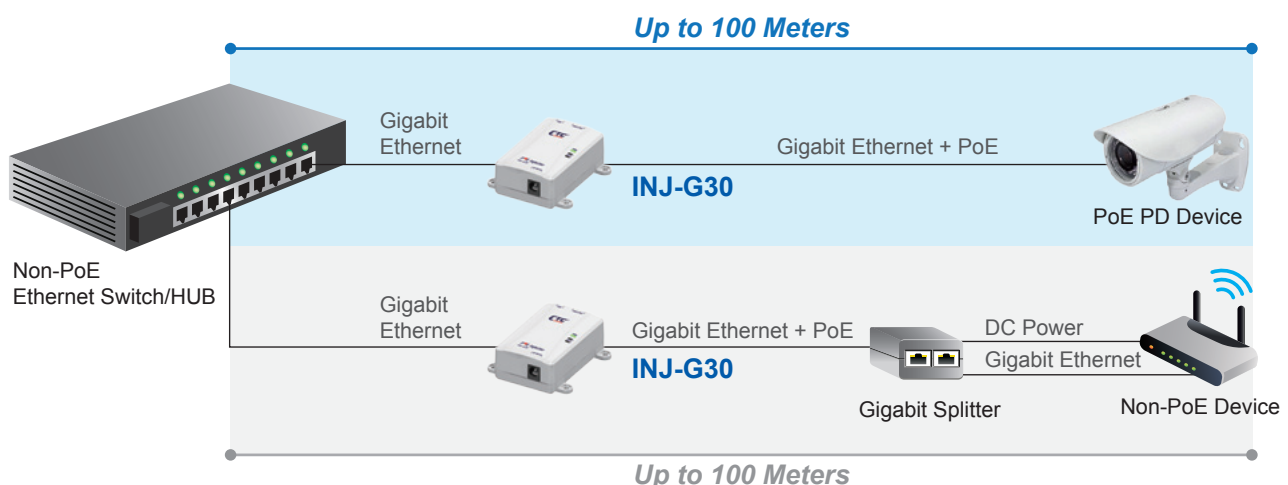

Ordering Information

Model Name	Description
INJ-G30	1 Port Gigabit Ethernet, IEEE802.3af/at high power PoE+ Injector



FMUX1001

Modularized 16E1/T1 + 4x GbE Managed Fiber Multiplexer

The FMUX1001 is a 1U, 19" rack mountable, PDH fiber optic multiplexer that transmits up to 16 channels plus a 10/100/1000Base-T Gigabit Ethernet channel over a single fiber optic link. The FMUX1001 chassis supports redundant power and hot swappable design. The AC supplies operate from 100~240VAC while DC supplies operate from 18~60VDC. From the rear of the chassis, one to four hot swappable quad E1 or T1 line cards, serial data communications (V.35, X.21, RS-530) or FXO/FXS voice cards are supported. The standard FMUX1001 configuration may be viewed or set via the front panel LCD/menu keys, serial VT-100 terminal connection, Telnet, web HTTP or SNMP.

Feature

- 1U, 19 (23)" 4-slot chassis
- 16 E1 (2.048Mb/s) Multiplexer with 100/1000Mbps Ethernet and RS-232 data (async) Interface
- RS-232 port for system console
- One alarm output port, one Order Wire port
- 4x 10/100/1000Base-T Ethernet ports
- SNMP management
- LCD plus menu keys for local configuration
- Port based VLAN, tag based VLAN & bandwidth control
- Telnet and web based remote configuration
- 2 plug-in SFP slot for optical SFP module

Specifications

Optical Interface	Connector	SFP - LC
	Data rate	1.25G
	Bit Error Rate	Less than 10 ⁻¹¹
	Fiber	MM 62.2/125µm, 50/125µm SM 9/125µm
	Distance	MM 2km. SM 15/30/50/80/120km WDM 20/40/60/80km
	Wavelength	1310, 1550nm
	Electrical Interface	Console, SNMP
Ethernet		4x RJ45
Alarm		RJ45

Standards	E1:ITU-T, T1:ITU-T, AT&T, ANSI, Ethernet: IEEE802.3x
Indications	PWR, Alarm, Phone, ACO, Port, Channels
Power Input	AC module IN : AC100 ~ 240V, Out : DC 12V
	DC module IN : DC 18 ~ 60V, Out : DC 12V
Power Consumption	< 25W
Dimensions	250 x 438 x 43mm (D x W x H)
Weight	3.58 kg
Temperature	0 ~ 50°C (Operating), 0 ~ 70°C (Storage)
Humidity	10 ~ 90% non-condensing
Certification	CE, FCC
MTBF	> 50000 hrs

Application

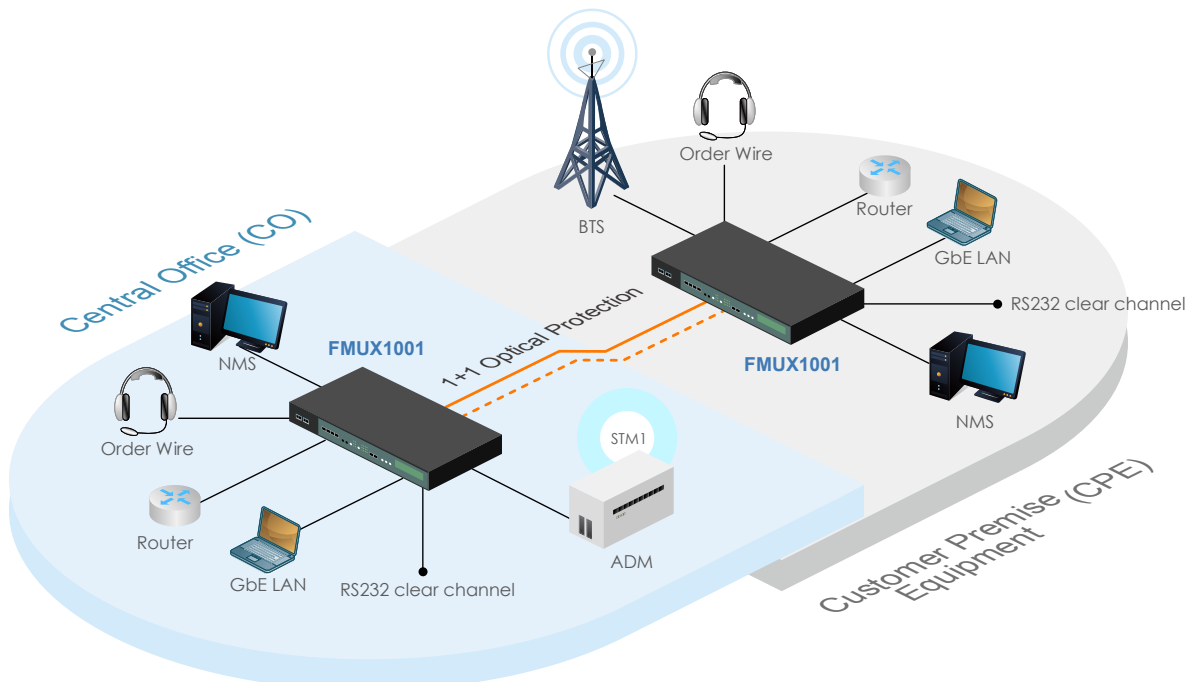



FMUX101

Modularized 16E1/T1 + 4x FE Managed Fiber Multiplexer

The FMUX101 is a 1U, 19" rack mountable, PDH fiber optic multiplexer that transmits up to 16 channels plus a 10/100Base-TX Fast Ethernet channel over a single fiber optic link. The FMUX101 chassis supports redundant power and hot swappable design. The AC supplies operate from 100~240VAC while DC supplies operate from 18~60VDC. From the rear of the chassis, one to four hot swappable quad E1 or T1 line cards, serial data communications (V.35, X.21, RS-530) or FXO/FXS voice cards are supported. The standard FMUX101 configuration may be viewed or set via the front panel LCD/menu keys, serial VT-100 terminal connection, Telnet, web HTTP or SNMP.

Feature

- 1U, 19 (23)" 4-slot chassis
- 16 E1 (2.048Mb/s) Multiplexer with 10/100Mbps Ethernet and RS-232 data (async) Interface
- RS-232 port for system console
- One alarm output port, one Order Wire port
- 4x 10/100Base-TX Ethernet ports
- SNMP management
- LCD plus menu keys for local configuration
- Port based VLAN, tag based VLAN & bandwidth control
- Telnet and web based remote configuration
- 2 plug-in SFP slot in optical SFP module

Specifications

Optical Interface	Connector	SFP- LC	Standards	E1:ITU-T, T1:ITU-T, AT&T, ANSI, Ethernet: IEEE802.3x	
	Data rate	155Mbps		Indications	PWR, Alarm, Phone, ACO, Port, Channels
	Bit Error Rate	Less than 10 ⁻¹¹			Power Input
	Fiber	MM 62.2/125μm, 50/125μm		DC24 : 18~60V	
		SM 9/125μm		Power Consumption	< 25W
	Distance	MM 2km. SM 15/30/50/80/120km			Dimensions
	WDM 20/40/60/80km	Weight	3.58kg		
	Wavelength		1310, 1550nm	Temperature	0 ~ 50°C (Operating), 0 ~ 70°C (Storage)
Electrical Interface	Console, SNMP	RJ45	Humidity		10 ~ 90% non-condensing
	Ethernet	4x RJ45		Certification	CE, FCC, RoHS compliant
	Alarm	RJ45	MTBF		25,000 hrs

Application

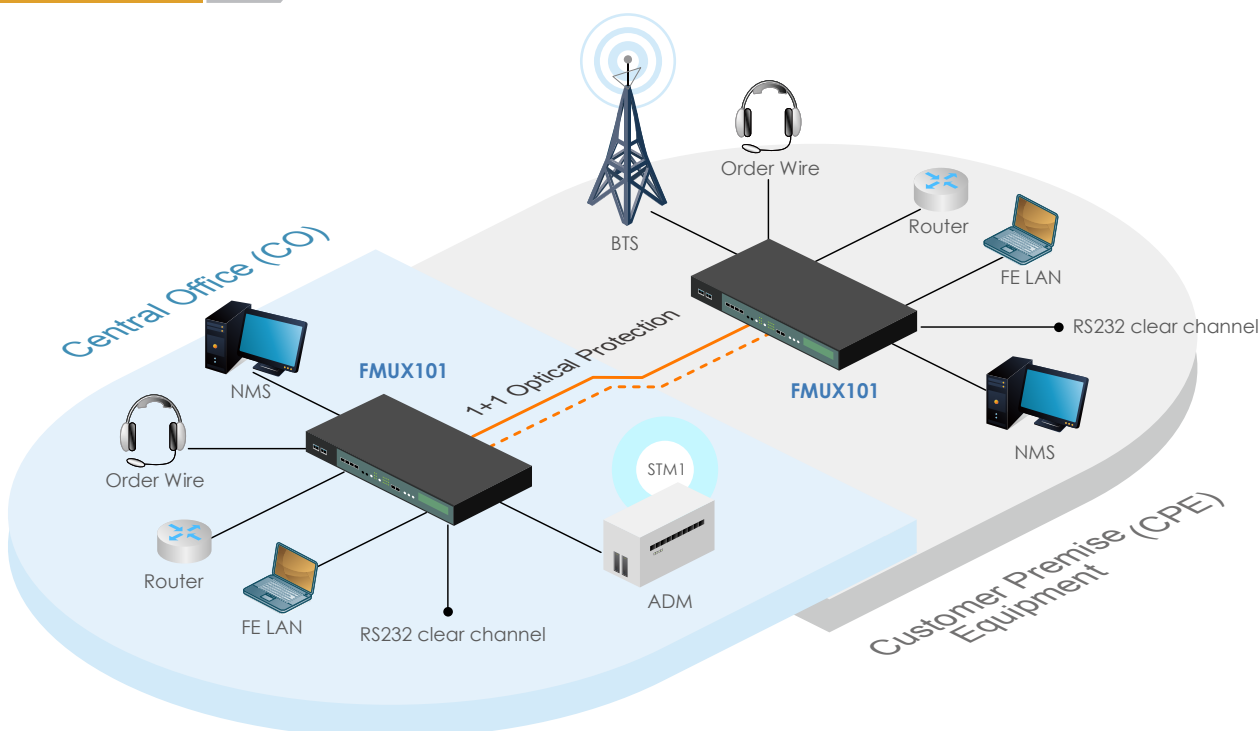

FMUX1001 & FMUX101 Interface Module



E1/T1 RJ-45 I/F



E1 BNC I/F

Standards	ITU-T G.703, G.704, AT&T TR-62411, ANSI T1.403	ITU-T G.703, G.704, G.706, G.732
Ports	4 ports	4 ports
Framing	Unframed (clear channel)	Unframed (clear channel)
Data rate	T1: 1.544 Mbps ±50 ppm, E1: 2.048 Mbps ±50 ppm	E1 2.048 Mbps ± 50 ppm
Line code	T1: B8ZS / AMI, E1: HDB3 / AMI	E1 HDB3/AMI
Receive Level	Short haul - 15dB	Short haul - 15dB
Line impedance	T1: 100 ohms ±5%, E1: 120 ohms ±5%, 75ohms ±5%	E1 75 ohms ± 5%
Connector	RJ-45	BNC 75 ohms



Datacom I/F

Standards	ITU-T, E1A
Card Type	V.35/ RS-530 (Include X.21 and RS-449)/ RS-232 I/F
Bit rate	n x 64K, n = 1 to 32 V.35 & RS-530 up to 2Mbps RS-232 up to 115.2Kbps (ASYNC)
Line code	NRZ
Clock Mode	Transparent, Recovery, External (From data port ETC) Internal (From oscillator)

Control Signal	CTS always On or follows RTS DSR constantly ON, except during test loops (RS-530 DSR always connect to DTR) DCD constantly ON, except during fiber signal loss
Test Loops	Local loop back, Remote loop back, V.54
Connector	Type Uses HD-68 pin D type Female with adapter cables



FXO/FXS I/F

Standards	G.711 A-law (separate modules for FXO, FXS)
Distance	2km
Bandwidth	64K voice channel
Connector	RJ45 x 4 (4 voice channel /per unit)

Ordering Information

Model Name	Type	Description
FMUX1001-CH	Chassis	1U 19" 4-Slot Rack Mount Chassis
FMUX101-CH	Chassis	1U 19" 4-Slot Rack Mount Chassis
FMUX-AC	Power	Chassis Power Module 110~240VAC
FMUX-DC	Power	Chassis Power Module 36~72VDC
FMUX-4E1/BNC	Card	4ch G.703 E1 BNC interface card
FMUX-4E1/T1-RJ45	Card	4ch E1/T1 RJ45 interface card
FMUX-4E1/T1-Wire	Card	4ch E1/T1 Wire Wrap interface card
FMUX-V35	Card	V35 interface card with one HD68M to 4 x MB34 cable
FMUX-530	Card	RS-530 interface card with one HD68M to 4 x DB25F cable

FMUX-449	Card	RS-449 interface card with one HD68M to 4 x DB37F cable
FMUX-X21	Card	X.21 interface card with one HD68M to 4 x DB15F cable
FMUX-232/Async	Card	RS-232 Async card with one HD68M to 4 x DB9F cable
FMUX-FXO	Card	4 x FXO interface card
FMUX-FXS	Card	4 x FXS interface card
FMUX-Phone-2W	Card	2 Wires order Wire (connect to analogue Telephone set)
FMUX-Phone-4W	Card	4 Wires order Wire (connect to Ear-Mic set)
FMUX-EXT/CLK	Card	External clock interface card

Example:

Chassis/Power/Line card Only

FMUX 1 0 0 1 - CH

1001 : GbE Fiber Multiplexer
101 : FE Fiber Multiplexer

FMUX A C

Power Module

FMUX V 3 5

I/F Line Card

Whole Set

FMUX 1 0 0 1 - A C - 2 W - A B C D

1001 : GbE
101 : FE

Power Type
AC
DC
AA : AC + AC
DD : DC + DC
AD : AC + DC

Order Wire
2W : 2 Wire Phone
4W : 4 Wire Phone

Card Type

A : 4x E1 BNC
B : 4x E1 RJ45
C : 4x T1 RJ45
D : 4x V.35
E : 4x RS-232/Async
F : 4x RS-530
G : 4x X.21
H : 4x RS-449
I : 4x FXO
J : 4x FXS
L : EXT/CLK



FMUX1600 FMUX800

16 or 8x E1/T1 + 4x GbE, Managed Fiber Multiplexer

The FMUX1600/FMUX800 is 1U 19" rack mountable, PDH fiber optical Multiplexer that transmits up to 16/8 E1/T1 + 4x 10/100/1000Base-T Gigabit Ethernet over a single fiber optic link. The FMUX1600/FMUX800 chassis is available in three different power configurations; single AC, single DC, or AC+DC. The AC supplies operate from 90 ~ 240VAC while DC supplies operate from 18~60VDC. On the rear of the chassis, the BNC model provides 32/16 unbalanced 75 Ohm coaxial connections with BNC connectors while the RJ-45 model provides 16/8 balanced 120 Ohm connections over twisted pair wiring with RJ45 connectors. With two SFP sockets on fiber ports, the FMUX1600/FMUX800 gives you the fiber cabling connector SFP-LC, both multi-mode and single-mode are available as well as BiDi which allows bi-directional transmissions using only a single fiber cable. 1+1 Automatic optical line protection is also supported for the aggregate fiber ports. The standard FMUX1600/FMUX800 configuration may be viewed or set via serial VT-100 terminal connection or SNMP card with web, telnet, and SNMP management

Feature

- Provides 16/8 E1/T1 G.703 transparent transmission over fiber
- Provide 4x 10/100/1000 Mbit/s Ethernet Ports
- Provides one RS232 channel
- Loopback test on E1/T1 fiber port
- Provides one hotline channel (order-wire)
- Supports full/half duplex, 10M/100M/1000M, auto-Negotiation
- Forward 10K byte jumbo packets on Ethernet port
- Supports 1+1 fiber line protection. Less than 50ms
- Complete alarm function and can monitor remote device status
- Power combination AC220V and DC-48V for redundant options
- Supports RS232 local management ; Supports on-line f/w upgrade
- Supports Web, Telnet, SNMP management (optional)

Specifications

Optical Interface	Connector	SFP- LC
	Data rate	1.25Gbps
	Bit Error Rate	Less than 10 ⁻¹¹
	Distance	MM 2km, SM 15/30/50/80/120km
	Wavelength	WDM 20/40/60/80km
Electrical Interface	Connector	Console : RS232 / SNMP : RJ45 Ethernet : RJ45 (4-port)
	Alarm	RS232 / Order wire : RJ11
E1 Interface	Standards	ITU-T G.703, G.704, G.706, G.732
	Ports	8/16 ports
	Data Rate	2.048 Mbps ± 50 ppm
	Line Code	HDB3/AMI
	Connector	RJ-45 for 120 ohms BNC for 75 ohms

T1 Interface	Standards	ITU-T G.703, G.704, AT&T TR-62411, ANSI T1.403
	Ports	8/16 ports
	Data Rate	1.544 Mbps ±50 ppm
	Line Code	B8ZS / AMI
	Connector	RJ-45 for 100 ohms
Certification	CE, FCC, RoHS compliant	
Standards	ITU-T G.703, G.823 and G.742, ANSI, AT&T, IEEE803.2, IEEE802.3u, IEEE802.3ab	
Indications	Power, Alarm, LBK, RD, LCK, RNG, ACO, Port, channel	
Power Input	90 ~ 240VAC, 18~60VDC	
Power Consumption	<25W	
Dimensions	250 x 438 x 43mm (D x W x H)	
Weight	3.58kg	
Temperature	0 ~ 60°C (Operating), -10 ~ 70°C (Storage)	
MTBF	50,000 hrs	

Application

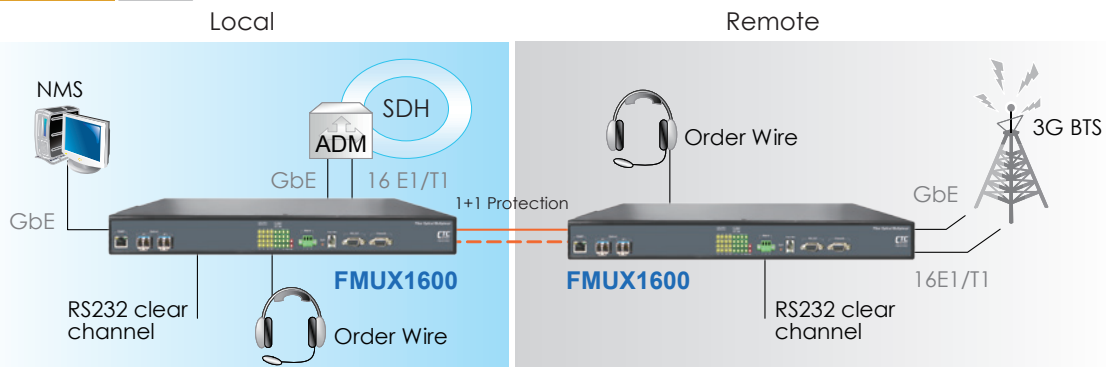

Ordering Information

Model Name	Description
FMUX1600B-AD	16x E1 BNC + 4x 10/100/1000Base-T Ethernet Fiber Multiplexer, build-in AC + DC Power
FMUX1600R-AD	16x E1/T1 RJ-45 + 4x 10/100/1000Base-T Ethernet Fiber Multiplexer, build-in AC + DC Power
FMUX1600-SNMP	SNMP Card with 10/100Base-TX Ethernet Port
FMUX800B-AD	8x E1 BNC + 4x 10/100/1000Base-T Ethernet Fiber Multiplexer, build-in AC + DC Power
FMUX800R-AD	8x E1/T1 RJ-45 + 4x 10/100/1000Base-T Ethernet Fiber Multiplexer, build-in AC + DC Power
FMUX800-SNMP	SNMP Card with 10/100Base-TX Ethernet Port
FMUX-Phone-2	2 Wires Order Wire
FMUX-Phone-4	4 Wires Order Wire

E1 Connector Type Power Type
FMUX1600 - □ - □ □
 Example: **FMUX1600-B-DC**
 Order Wire
FMUX-Phone - □
 Example: **FMUX-Phone-2**



FMUX160 FMUX80

16 or 8x E1/T1 + 4x FE, Managed Fiber Multiplexer

The FMUX160/FMUX80 is 1U 19" rack mountable, PDH fiber optical Multiplexer that transmits up to 16/8 E1/T1 + 4x 10/100Base-TX Fast Ethernet over a single fiber optic link. The FMUX160/FMUX80 chassis is available in three different power configurations; single AC, single DC, or AC+DC. The AC supplies operate from 90 ~ 240VAC while DC supplies operate from 18~60VDC. On the rear of the chassis, the BNC model provides 32/16 unbalanced 75 Ohm coaxial connections with BNC connectors while the RJ-45 model provides 16/8 balanced 120 Ohm connections over twisted pair wiring with RJ45 connectors. The FMUX160/FMUX80 gives you the fiber cabling connector ST SC FC, both multi-mode and single-mode are available as well as BiDi which allows bi-directional transmissions using only a single fiber cable. 1+1 Automatic optical line protection is also supported for the aggregate fiber ports. The standard FMUX160/FMUX80 configuration may be viewed or set via serial VT-100 terminal connection or SNMP card with web, telnet, and SNMP management

Feature

- Provides 16/8 E1/T1 G.703 transparent transmission over fiber
- Provide 4x 10/100 Mbit/s Ethernet Ports (100Mbps aggregate)
- Provides one RS232 channel
- Loopback test on E1/T1 fiber port
- Provides one hotline channel (order-wire)
- Supports full/half duplex, 10M/100M, auto-Negotiation
- Forward 1792 byte packets on Ethernet port
- Supports 1+1 fiber line protection. Less than 50ms
- Complete alarm function and can monitor remote device status
- Power combination AC220V and DC-48V for redundant options
- Supports RS232 local management ; Supports on-line f/w upgrade
- Supports Web, Telnet, SNMP management (optional)

Specifications

Optical Interface	Connector	ST, SC, FC	
	Data rate	155.52Mbps	
	Bit Error Rate	Less than 10 ⁻¹¹	
	Distance	MM 2km, SM 15/30/50/80/120km WDM 20/40/60/80km	
	Wavelength	1310nm, 1550nm, CWDM 1471nm~1611nm	
Electrical Interface	Connector	Console : RS232 / SNMP : RJ45 Ethernet : RJ45 (4-port) Alarm : RS232 / Order wire : RJ11	
	E1 Interface	Standards	ITU-T G.703, G.704, G.706, G.732
	Ports	8/16 ports	
	Data Rate	2.048 Mbps ± 50 ppm	
	Line Code	HDB3/AMI	
	Connector	RJ-45 for 120 ohms BNC for 75 ohms	

T1 Interface	Standards	ITU-T G.703, G.704, AT&T TR-62411, ANSI T1.403
	Ports	8/16 ports
	Data Rate	1.544 Mbps ±50 ppm
	Line Code	B8ZS / AMI
	Connector	RJ-45 for 100 ohms
Certification	CE, FCC, RoHS compliant	
Standards	ITU-T G.703, G.823 and G.742, ANSI, AT&T, IEEE803.2, IEEE802.3u	
Indications	Power, Alarm, LBK, RD, LCK, RNG, ACO, Port, channel	
Power Input	90 ~ 240VAC, 18~60VDC	
Power Consumption	<25W	
Dimensions	250 x 438 x 43mm (D x W x H)	
Weight	3.58kg	
Temperature	0 ~ 60°C (Operating), -10 ~ 70°C (Storage)	
MTBF	75,000 hrs	

Application

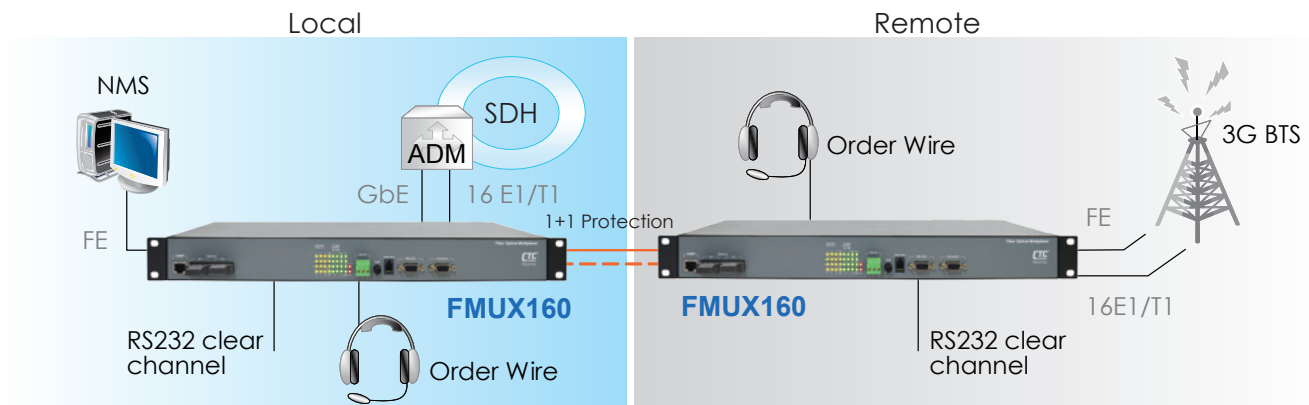

Ordering Information

Two Fiber model

Model Name	Description
FMUX160B-AD-2SC002	16x E1 BNC + 4 x 10/100Base-T Ethernet Fiber Multiplexer, with two MM 2km SC fiber, AC+DC Power
FMUX160R-AD-2SC002	16x E1/T1 RJ45 + 4 x 10/100Base-T Ethernet Fiber Multiplexer, with two MM 2km SC fiber, AC+DC Power
FMUX80B-AD-2SC002	8x E1 BNC + 4 x 10/100Base-T Ethernet Fiber Multiplexer, with two MM 2km SC fiber, AC+DC Power
FMUX80R-AD-2SC002	8x E1/T1 RJ45 + 4 x 10/100Base-T Ethernet Fiber Multiplexer, with two MM 2km SC fiber, AC+DC Power

One Fiber model

Model Name	Description
FMUX160B-AD-SC002	16x E1 BNC + 4 x 10/100Base-T Ethernet Fiber Multiplexer, with one MM 2km SC fiber, AC+DC Power
FMUX160R-AD-SC002	16x E1/T1 RJ45 + 4 x 10/100Base-T Ethernet Fiber Multiplexer, with one MM 2km SC fiber, AC+DC Power
FMUX80B-AD-SC002	8x E1 BNC + 4 x 10/100Base-T Ethernet Fiber Multiplexer, with one MM 2km SC fiber, AC+DC Power
FMUX80R-AD-SC002	8x E1/T1 RJ45 + 4 x 10/100Base-T Ethernet Fiber Multiplexer, with one MM 2km SC fiber, AC+DC Power

Optional modules

Model Name	Description
FMUX160-SNMP	SNMP Card with 10/100Base-TX Ethernet Port
FMUX80-SNMP	SNMP Card with 10/100Base-TX Ethernet Port
FMUX-Phone-2	2 Wires Order Wire with RJ9 to RJ11 cable
FMUX-Phone-4	4 Wires Order Wire

Example:

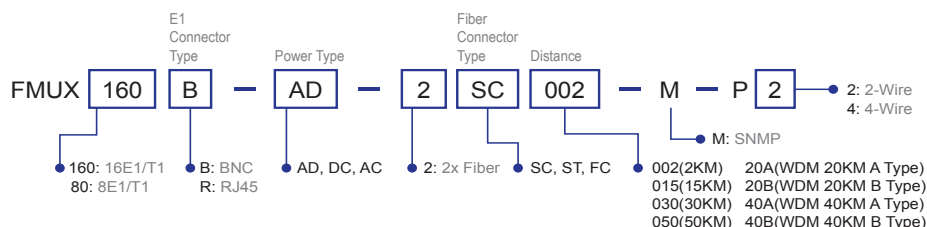



FMUX04E

4E1/T1 + 3x FE Fiber Multiplexer

FMUX04E is a fixed design for 4x E1 + Fast Ethernet multi-service to dual strand fiber PDH multiplexer. FMUX04E provides E1 transmission transparently and pure 100Mbps Fast Ethernet simultaneously. The fiber optic line is based on SFP technology that allows the flexible use of Multimode or Single mode lines and enables support for different wavelengths and distances. The use of bi-directional SFPs maximizes the utilization of fiber optic line and results in saving line costs. The multiplexer can be equipped with optional AC and DC power supplies for redundant operation. With SNMP and Web-based management in the FMUX04E, the Network administrator can monitor, configure and control the activity remotely.

Feature

- 4 channels unframed E1/T1
- 3-CH 10/100Base-TX Ethernet
- Auto MDI/MDIX
- Auto-Negotiation or Force mode
- Supports flow control
- Supports 1552 packets (max)
- One clear channel RS232 up to 250Kbps(Async)
- 1+1 fiber protection, less than 50ms
- Supports Digital Diagnostics Monitoring Interface (DDMI)
- AIS on signal loss on E1/T1 and fiber port
- Port based VLAN function
- Loopback test on E1/T1, RS-232, fiber ports
- Supports Dying Gasp
- Supports local or remote In-band management
- Optional SNMP management
- Supports Order wire Ear / Microphone port.
- Supports On-Line F/W upgrade (local or remote) by the SNMP manager

Specifications

E1/T1	Framing: Unframed (transparent) Bit Rate: E1:2.048 Mb/s , T1: 1.544Mb/s Line Code: E1:AMI/HDB3, T1: AMI/B8ZS Line Impedance: E1: Unbalanced 75 ohms (BNC) E1: Balanced 120 ohms (RJ-45) T1: Balanced 120 ohms (RJ-45) Receiver sensitivity: Short haul Jitter Performance: According to ITU-T G.823 Standard: ITU-T G.644, G.703, G.704, G.706 and G.732 Interface Connectors: RJ-45, BNC Test Loops: LLB (Local Loop Back) RLB (Remote Loop Back) RRLB (Request Remote Loop Back)	Optical Interface	Optical Wavelength: 1310nm, 1550nm, WDM Tx1310/Rx1550nm (Type A), WDM Tx1550/Rx1310nm (Type B)
Optical Interface	Bandwidth in optical Line: 155 Mbps Optical Connector: LC (SFP module) Distance: 20/40/80 Km	Ethernet	Interface Type: 10/100Base-TX Connector: 3x RJ-45 Standard: IEEE 802.3, 802.3u Duplex modes: full/half
		Indication	FX1 Link, FX2 link, E1/T1 Mode/Link/Loopback test, Order wire phone indicator , LAN Link/Speed
		Power Input	AC : 100~240VAC, DC : 18-75 VDC
		Dimensions	248 x 215 x 43mm (D x W x H)
		Operating Temperature	0 ~ 50°C (Operating) -10 ~ 20°C (Storage)
		Humidity	10 ~ 90% non-condensing
		Certifications	CE, FCC, RoHS compliant
		MTBF	75,000 hrs

Application

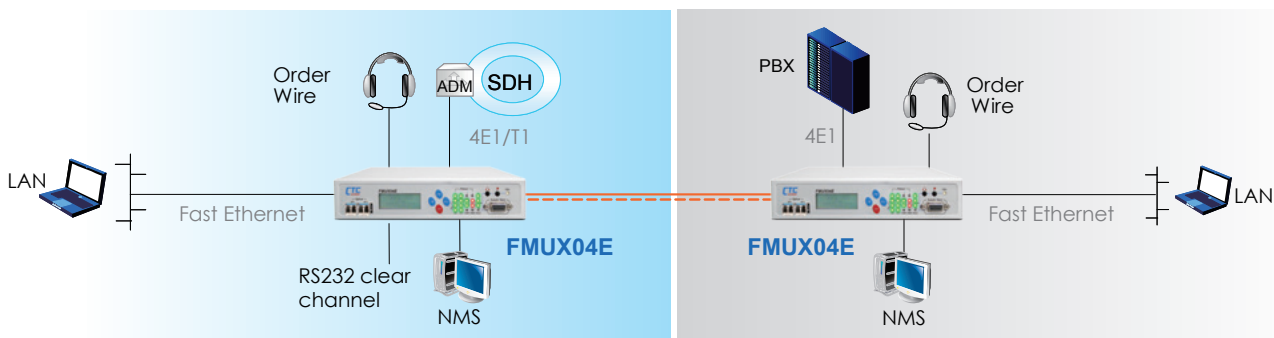

Ordering Information

Model Name	Description
FMUX04E-AC,DC,AD	Standalone FOM with built-in AC, DC or AD (AC+DC) Power, optional SNMP
FMUX04E-SNMP	SNMP management card, support web, telnet, SNMP functions

Note: SNMP option only required in one unit of paired link



FMUX04

4E1/T1 Fiber Multiplexer

The FMUX04 is a 1U half 19" stand-alone or rack mountable point-to-point multiplexer for 4*E1 or 4*T1 (selectable) transmissions over a single fiber optic link. Its half-rack format makes it ideal for low cost multiplexing applications that require up to 4-channel. All channels provide completely transparent transmission of E1 or T1 regardless of frame mode, clock source or timeslot assignment. Available in either AC or DC models, the AC supplies operate from 100~240VAC while DC supplies operate from 18~72VDC. A wide range of transceiver selection provides fiber connection with SC, FC or ST type connectors in multimode or single mode and at distance from 2 to 120km as well as BiDi (single fiber) at distances of 20, 40, 60, or 80km. Additional options include "Order Wire" phone connection (FXS port) and a SNMP management.

Feature

- 1U stand-alone unit
- Channel service setting and remote loop-back setting via front panel DIP switch or serial console
- Far End Fault (FEF) on fiber link, selectable
- On-line Bit Error Rate monitor feature with four error-rate classes
- Dual color LEDs indicators
- Optional dedicated Order Wire phone port (FXS, RJ-11 port)
- Console port and one alarm relay
- Optional SNMP management, Telnet, and Web Based local and remote configuration
- System BER 10⁻¹¹

Specifications

Optical Interface	Connector	1x 9 (SC, ST, FC)
	Data rate	38Mbps
	Bit Error Rate	Less than 10 ⁻¹¹
	Fiber	MM 62.2/125μm, 50/125μm SM 9/125μm
	Distance	MM 2km, SM 15/30/50/80/120km, WDM 20/40/60/80km
Electrical Interface	Wavelength	1310, 1550nm
	Console	RS-232 (DB9F) Async
	SNMP / Order wire	RJ-45 / RJ11
Standard	E1	BNC 75 Ω, RJ45 120 Ω, T1 RJ45 100 Ω
	E1: ITU-T, T1: ITU-T, AT&T, ANSI	

Indication	PWR, Alarm, Far End /Near End Error System failure, E1/T1 status
Power input	AC : 100 ~240V DC24 : 18 ~ 36V, DC48 : 36 ~ 72V
Power Consumption	<20W
Dimensions	235 x 195 x 45mm (D x W x H)
Weight	0.85kg
Temperature	0 ~ 50°C (Operating), 0 ~ 70°C (Storage)
Humidity	10 ~ 90% non-condensing
Certification	CE, FCC, RoHS compliant
MTBF	75,000 hrs

Application

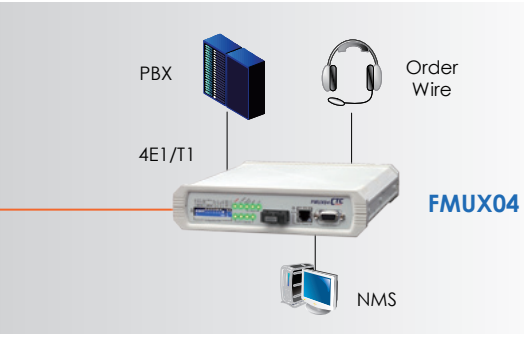
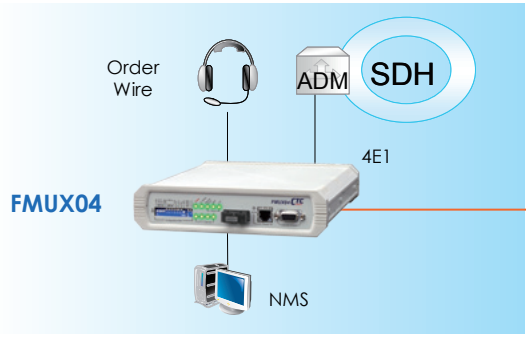

Ordering Information

Model Name	Description
FMUX04-AC/SC015	SC, 15Km, 1310nm, 12dB
FMUX04-AC/SC030	SC, 30Km, 1310nm, 20dB
FMUX04-AC/SC050	SC, 50Km, 1310nm, 28dB
FMUX04-AC/SC080	SC, 80Km, 1550nm, 29dB
FMUX04-AC/SC120	SC, 120Km, 1550nm, 35dB, DFB Laser
FMUX04-AC/SC20A	SC, 20km, Tx1310 /Rx1550nm (A type), 17dB
FMUX04-AC/SC20B	SC, 20km, Tx1550 /Rx1310nm (B type), 14dB
FMUX04-AC/SC40A	SC, 40km, Tx1310 /Rx1550nm (A type), 25dB
FMUX04-AC/SC40B	SC, 40km, Tx1550 /Rx1310nm (B type), 22dB, DFB Laser
FMUX04-AC/SC60A	SC, 60km, Tx1310 /Rx1550nm (A type), 29dB
FMUX04-AC/SC60B	SC, 60km, Tx1550 /Rx1310nm (B type), 29dB, DFB Laser

Power Type Connector Type Connectivity Distance

FMUX04 – □□ / □□□□□

Example: FMUX04 – AC / SC015

Model Name	Description
FMUX04-DC/SC002	SC, MM, 2Km, 1310nm, 11dB
FMUX04-DC/SC015	SC, 15Km, 1310nm, 12dB
FMUX04-DC/SC030	SC, 30Km, 1310nm, 20dB
FMUX04-DC/SC050	SC, 50Km, 1310nm, 28dB
FMUX04-DC/SC080	SC, 80Km, 1550nm, 29dB
FMUX04-DC/SC120	SC, 120Km, 1550nm, 35dB, DFB Laser
FMUX04-DC/SC20A	SC, 20km, Tx1310 /Rx1550nm (A type), 17dB
FMUX04-DC/SC20B	SC, 20km, Tx1550 /Rx1310nm (B type), 14dB
FMUX04-DC/SC40A	SC, 40km, Tx1310 /Rx1550nm (A type), 25dB
FMUX04-DC/SC40B	SC, 40km, Tx1550 /Rx1310nm (B type), 22dB, DFB Laser
FMUX04-DC/SC60A	SC, 60km, Tx1310 /Rx1550nm (A type), 29dB
FMUX04-DC/SC60B	SC, 60km, Tx1550 /Rx1310nm (B type), 29dB, DFB Laser



SFP Fiber Transceiver

Hot-Pluggable
Fiber Transceiver Modules

SFP Transceivers are high performance, cost effective modules for serial optical data communications applications specified for a single mode at 1.25/2.5Gbps. They operate with +3.3V/5V power supplies and are intended for single mode or multi-mode fiber, operating at a nominal wavelength of 1310(850) nm. Each SFP Transceiver consists of a transmitter optical subassembly, a receiver optical subassembly and an electrical subassembly. SFP Transceivers are duplex SC/ LC transceiver designed for use in Gigabit Ethernet and to provide an IEEE-802.3z compliant link for 1.25/2.5Gbps short or long reach applications.

Feature

- SFP & SFP+ Multi-Source Agreement compliant
- Single 3.3V power supply
- Duplex or Simplex LC receptacle connector
- Up to 10Gb/s bi-directional data links
- Class 1 laser safety standard IEC825 compliant
- Hot Pluggable
- Lower power dissipation

155Mbps 100Base-X Dual fiber SFP

Model Name	Wavelength(nm)	Media	Optical Power(dBm)	Sensitivity(dBm)	Power Budget(dB)	Distance	DDMI
SFM-5000-L31	1310	MMF	-20~-14	-32	12	2km	
SFM-5000-L31-DD	1310	MMF	-20~-14	-32	12	2km	✓
SFS-5030-L31	1310	SMF	-15~-8	-34	19	30km	
SFS-5030-L31-DD	1310	SMF	-15~-8	-34	19	30km	✓
SFS-5050-L31	1310	SMF	-5~0	-35	30	50km	
SFS-5050-L31-DD	1310	SMF	-5~0	-35	30	50km	✓

155Mbps 100Base-BX, Single fiber Bi-Directional SFP

Model Name	Wavelength(nm)	Media	Optical Power(dBm)	Sensitivity(dBm)	Power Budget(dB)	Distance	DDMI
SFS-5020-WA	T1310 / R1550	SMF	-14~-8	-32	18	20km	
SFS-5020-WA-DD	T1310 / R1550	SMF	-14~-8	-32	18	20km	✓
SFS-5020-WB	T1550 / R1310	SMF	-14~-8	-32	18	20km	
SFS-5020-WB-DD	T1550 / R1310	SMF	-14~-8	-32	18	20km	✓

1.25Gbps (1000Base-X, Fiber Channel) SFP

Model Name	Wavelength(nm)	Media	Optical Power(dBm)	Sensitivity(dBm)	Power Budget(dB)	Distance	DDMI
SFM-7000-S85	850	MMF	-9.5~-4	-17	7.5	550m	
SFM-7000-S85-DD	850	MMF	-9.5~-4	-17	7.5	550m	✓
SFM-7000-L31	1310	MMF	-9~-1	-19	10	2km	
SFM-7000-L31-DD	1310	MMF	-9~-1	-19	10	2km	✓
SFS-7010-L31	1310	SMF	-9.5~-3	-20	10.5	10km	
SFS-7010-L31-DD	1310	SMF	-9.5~-3	-20	10.5	10km	✓
SFS-7020-L31	1310	SMF	-8~-2	-23	15	20km	
SFS-7020-L31-DD	1310	SMF	-8~-2	-23	15	20km	✓
SFS-7040-L31	1310	SMF	-2~-3	-23	21	40km	
SFS-7040-L31-DD	1310	SMF	-2~-3	-23	21	40km	✓

1.25Gbps (1000Base-X, Single Fiber Bi-Directional) SFP

Model Name	Wavelength(nm)	Media	Optical Power(dBm)	Sensitivity(dBm)	Power Budget(dB)	Distance	DDMI
SFS-7020-WA	T1310 / R1550	SMF	-7~-2	-22	15	20km	
SFS-7020-WA-DD	T1310 / R1550	SMF	-7~-2	-22	15	20km	✓
SFS-7020-WB	T1550 / R1310	SMF	-7~-2	-22	15	20km	
SFS-7020-WB-DD	T1550 / R1310	SMF	-7~-2	-22	15	20km	✓
SFS-7040-WA	T1310 / R1550	SMF	-3~-2	-23	20	40km	
SFS-7040-WA-DD	T1310 / R1550	SMF	-3~-2	-23	20	40km	✓
SFS-7040-WB	T1550 / R1310	SMF	-3~-2	-23	20	40km	
SFS-7040-WB-DD	T1550 / R1310	SMF	-3~-2	-23	20	40km	✓

10Gbps SFP+

Model Name	Wavelength(nm)	Media	Optical Power(dBm)	Sensitivity(dBm)	Power Budget(dB)	Distance	DDMI
SFM-1000-SR85	850	MMF	-6.5~-1	-11.1	4.6	300m	✓
SFS-1010-LR31	1310	SMF	-8.2~-0.5	-14.4	6.2	10km	✓
SFS-1040-ER55	1550	SMF	-3~-3	-15.8	12.8	40km	✓
SFS-1080-ZR55	1550	SMF	0~4	-24	24	80km	✓

10Gbps XFP

Model Name	Wavelength(nm)	Media	Optical Power(dBm)	Sensitivity(dBm)	Power Budget(dB)	Distance	DDMI
XFM-1000-SR85	850	MMF	-6.5~-1	-11.1	4.6	300m	✓
XFS-1010-LR31	1310	SMF	-8~0	-14.4	4.6	10km	✓
XFS-1040-ER55	1550	SMF	-3~-3	-15.8	11.1	40km	✓
XFS-1080-ZR55	1550	SMF	0~4	-24	24	80km	✓

Naming Rule

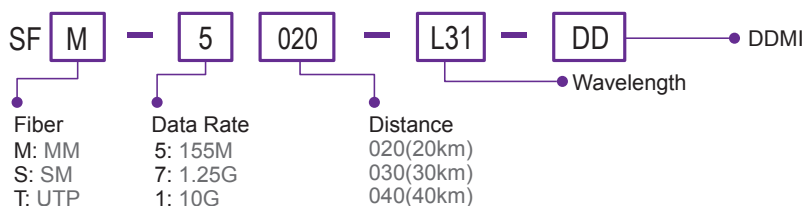



VDTU2A-404

4x GbE LAN Extender

The VDTU2A-404 VDSL2 LAN Extender is a high-speed Ethernet Extender designed for applications under harsh environment. It is equipped with 4 Gigabit Ethernet Ports (RJ-45 connector) and one VDSL port (RJ-45 connector) in metal enclosure for easy installation in harden environment. It is a bridge mode modem, well accommodating VDSL2 (Very-high-data-rate Digital Subscriber Loop) technology to extend Ethernet service over single-pair phone line. It is compliant to ITU-T G.993.2 standard and supports VDSL2 30a profile that features 100Mbps of symmetric data rate over the existing copper wires. Supporting both symmetric and asymmetric transmission, it can reach up to 190/110Mbps bandwidth (line rate) within 300M. By providing ultra-high speed, the VDTU2A-404 VDSL2 LAN Extender makes your telephone line achieve its best performance than before. It has the advantage of minimum installation time (simply as plug-n-play) and minimum expense by allowing video streaming and data to share the same telephone pair without interference.

The VDTU2A-404 VDSL2 LAN Extender delivers everything needed to quickly deploy a high-speed IP-based network for providing high-speed Internet access, video-on demand services and voice services. The resulting compact, cost-effective form factor offers Systems Integrators, small business owners an attractive Long Reach Ethernet solution.

Feature

- Metal enclosure for easy installation in Utility applications
- Cost effective bridge function to connect two Ethernet LAN
- IEEE 802.1Q VLAN tag transparent
- Easy installation via simple plug-and-play
- Supports VDSL2 Profile 30a High Throughput mode
- Supports VDSL2 Profile 17a long Reach mode

Specifications

VDSL Interface	RJ-45 connector DMT Encoding Complying with ITU-T G993.1/993.2/G.997.1 On-board surge protection
LAN Interface	4 x RJ-45 connectors 10/100/1000 Base-T; Auto-Negotiation, Auto-MDI/MDI-X. Complying with IEEE 802.3/802.3u/802.3z
4-position DIP Switch	Selectable CO or CPE mode Selectable Fast or interleave mode Selectable 30a or 17a (VDSL2 Profile) Selectable target SNR margin (6dB or 9dB)
LED	Power: On/Off LAN: Fast Ethernet/Gigabit Ethernet VDSL2: Mode - CO/CPE Link - Idle/Trained/Link
Power supply	External 12V/1A Power Adaptor
Power Consumption	4.5 Watts maximum
Dimension	110.7 x 88 x 40mm (DxWxH)
Operating Temperature	0°C ~50°C (Adaptor), -40 ~ 70°C (LAN Extender)
Humidity	0%~95%RH (non-condensing)

Installation	Wall Mounting or Magnet Kit (optional)
Regulatory Compliance	CE, FCC Part 15 Class A, EN60950

Performance		
UTP, 24AWG		
Profile 30a : High Throughput Mode		
Distance (Feet)	Upstream Line Rate (Mbps)	Downstream Line Rate (Mbps)
500	97	183
1000	59	136
1500	40	96
2000	24	64
2500	10	56
3000	6	43
UTP, 24AWG		
Profile 17a : Long Reach Mode		
Distance (Feet)	Upstream Line Rate (Mbps)	Downstream Line Rate (Mbps)
500	54	129
1000	49	112
1500	39	84
2000	23	60
2500	11	45
3000	6	40
4000	1	31
6000	0.64	14
9000	0.36	4

Application

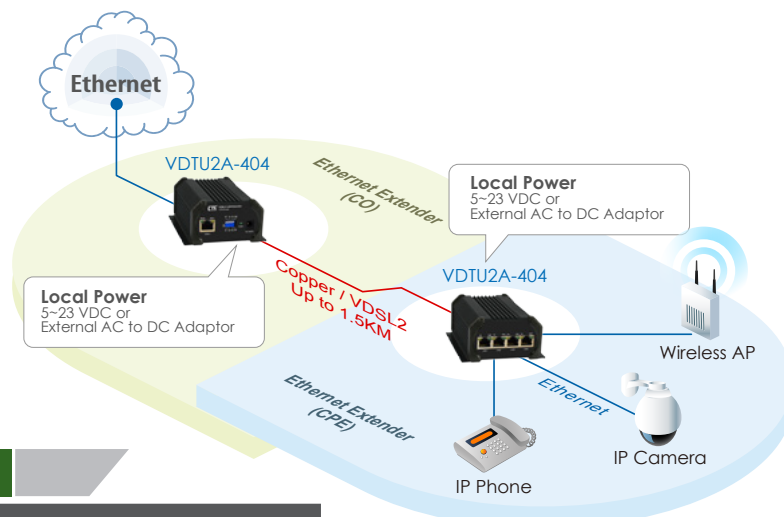

Ordering Information

Model Name	Description
VDTU2A-404	4-Port 10/100/1000Base-T LAN Extender



VDTU2A-304

4x 10/100Base-TX LAN Extender

The VDTU2A-304 LAN Extender is a long reach Ethernet extender with four Ethernet ports and two phone jacks, in which one is for VDSL2 connection and the other is for POTS (Plain Old Telephone Service) connection. It has built-in POTS splitter to share the existing phone line with POTS eliminating the need for replacing the existing copper wiring. It is ideal for use as an Ethernet extender to an existing Ethernet network. While accommodating VDSL2 (Very-high-data-rate Digital Subscriber Loop) technology to extend Ethernet service over single-pair phone line, VDTU2A-304 can reach up to 100/75 Mbps bandwidth (line rate) within 300M or 40/10 Mbps bandwidth (line rate) for 1 Km long-range connections. By providing ultra-high speed, VDTU2A-304 LAN Extender makes your telephone line achieve its best performance ever. It has the advantage of minimum installation time (simple as plug-n-play) and minimum expense by allowing video streaming and data to share the same telephone pair without interference. VDTU2A-304 delivers everything needed to quickly deploy a high-speed IP-based network for providing high-speed Internet access, video-on demand services and voice services. The resulting compact, cost-effective form factor offers systems integrators and small business owners an attractive long reach Ethernet solution.

Feature

- Cost effective bridge function to connect two Ethernet LAN
- Easy installation via simple plug-and-play
- Selectable CPE and CO mode : Two working modes are built in the same unit, which keep the flexibility of installation and easy provision of service but lower inventory of service provider.
- Selectable fast and interleaved mode: Fast mode guarantees a minimum end to end latency less than 1 mS. Interleaved mode provides impulse noises protection for any impulse noise with duration less than 250uS. Interleaved mode has a maximum end to end latency of 10mS.
- Selectable target band plan : VDSL2 defines multiple band plans and configuration modes to allow asymmetric and symmetric services in same binder for data transmission.
- Asymmetric is selected that provides better downstream performance. Symmetric is selected that provides better upstream performance.
- Selectable target SNR margin: It has the ability to select fixed SNR margin value on 9 dB or 6db. The systems will maintain the SNR margin at their value across all usable loop length. The higher SNR value gets better line quality, but lower performance.

Specifications

Standards	Compliant with ITU VDSL2 standard G.993.2 Annex A, Annex B and Annex C Supports VDSL2 profile : 8a, 8b, 8c, 8d, 12a, 12b and 17a Band plan profile: symmetric (Plan 997) and asymmetric (Plan 998) Supports fast and interleaved mode Target SNR Margin : Selectable Built-in POTS splitter to share voice and data (Optional)	Interfaces	Ethernet : 4x RJ-45 connectors for Ethernet 10/100Mbps ports with Auto-MDI/MDIX VDSL : 1x RJ-11 connector for VDSL2 port Phone : 1x RJ-11 connector for POTS Splitter (Optional) General : PWR and SYS WAN (VDSL2) : CO, CPE, LINK and ALM LAN (Ethernet) : 1, 2, 3, 4 LNK/ ACT
Management	Web-based GUI for quick setup, configuration and management Firmware upgradable from Web	Indicators	General : PWR and SYS WAN (VDSL2) : CO, CPE, LINK and ALM LAN (Ethernet) : 1, 2, 3, 4 LNK/ ACT
LAN	Filtering functions for MAC/IP/Port QoS for Port/VLAN/DSCP/TCP-UDP Port number Port Based VLAN & IEEE 802.1q VLAN Tagging Port configuration for Bandwidth/Duplex/Speed/Flow control/Broadcast storm	Power	Input : AC 90~240V/50 ~ 60Hz ; Output : DC 12V/1A
		Power consumption	9 watts maximum
		Environment	Temperature : 0 ~ 45°C Humidity : 0% ~ 95% (non-condensing)
		Dimensions	131.5 x 180 x 36.5 mm (D x W x H)
		Weight	300g

Application

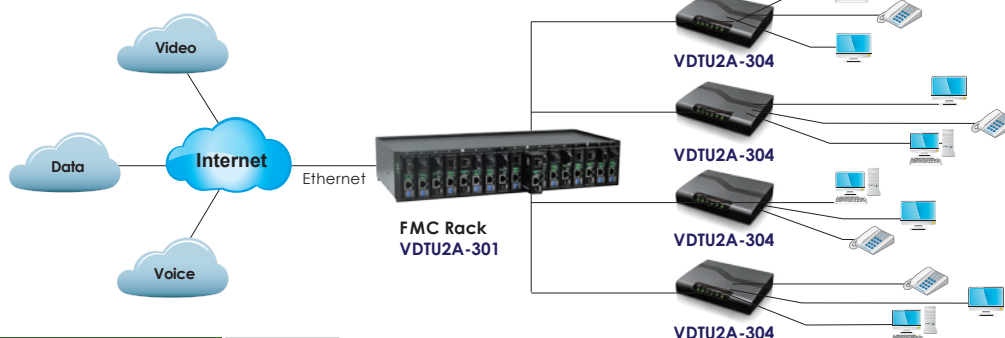

Ordering Information

Model Name	Description
VDTU2A-304/US	4-port 10/100Base-TX LAN Extender with splitter 600 ohm



VDTU2A-301

10/100Base-TX LAN Extender

The VDTU2A-301 is our lowest cost LAN extension solution using the G993.1/993.2 VDSL2 technology and providing up to 100Mbps throughput with only a single copper wire pair. A LAN extender is a device that forwards traffic between LANs transparently to higher network-layer protocols over distances that far exceed the distance limitations of standard Ethernet. A LAN is a high-speed data network (usually employing Ethernet technology) that connects computer workstations, printers, servers, and other devices. Designed specifically for LAN to LAN extension and supporting both symmetrical and asymmetrical transmission at up to 100/75Mbps within 300 meters or 10/10Mbps rate at 1000 meters, this is a perfect solution to extend a LAN to an adjacent building, garage or any location outside of the 100 meter reach of Ethernet UTP.

Feature

- Cost effective bridge function to connect two Ethernet LANs
- 100/75Mbps @ 300m (980 Ft)
- 10/10Mbps @ 1km (3300 Ft)
- Supports flow control via Pause frame or back pressure
- 802.1Q VLAN tag transparent
- Selectable CPE and CO mode via DIP switch
- Selectable fast and interleaved mode
- Selectable target band plan
- Selectable target SNR margin 9dB or 6dB

Specifications

LAN Interface	Complies with IEEE 802.3 10Base-T and 802.3u 100Base-TX Connector : RJ45 MTU : 1536 Bytes	Power Consumption	4.2W
VDSL2 Interface	Complies with ITU-T G993.1/993.2/ G997.1 Connector : RJ45 DMT encoding On-board surge protection	Dimensions	97 x 73 x 23mm (D x W x H)
4-position DIP Switch	Selectable CO or CPE mode Selectable fast or interleave mode (Impulse noise protection) Selectable Band plan (Symmetric or Asymmetric) Selectable target SNR margin (6dB or 9dB)	Weight	80g
Indicator	LAN : Act/Link, 10/100Mbps, Half/Full duplex VDSL : CO/CPE, Idle/Trained/Link, Power	Temperature	0 ~ 50°C (Operating), -10 ~ 70°C (Storage)
Standard	ITU-T G.993.1, 993.2, IEEE802.3, 802.3u	Humidity	10 ~ 90% non-condensing
Power	DC 12V via AC switching adapter	Certification	CE, FCC, RoHS compliant
		MTBF	50,000 hrs
		Emission	EN 55022: 2006 + A1:2007, Class B AS/NZS CISPR 22: 2006, Class B EN 61000-3-2: 2006 + A1: 2009 + A2: 2009, Class A EN 61000-3-3: 2008
		Immunity	EN 55024: 1998 + A1: 2001 + A2:2003 IEC 61000-4-2: 2008 ED.2.0 IEC 61000-4-3: 2006+A1: 2007 ED.3.0 IEC 61000-4-4: 2004+A1: 2010 ED.2.0 IEC 61000-4-5: 2005 ED.2.0 IEC 61000-4-6: 2008 ED.3.0 IEC 61000-4-8: 2009 ED.2.0 IEC 61000-4-11: 2004 ED.2.0

Application

Rack to Standalone Solution

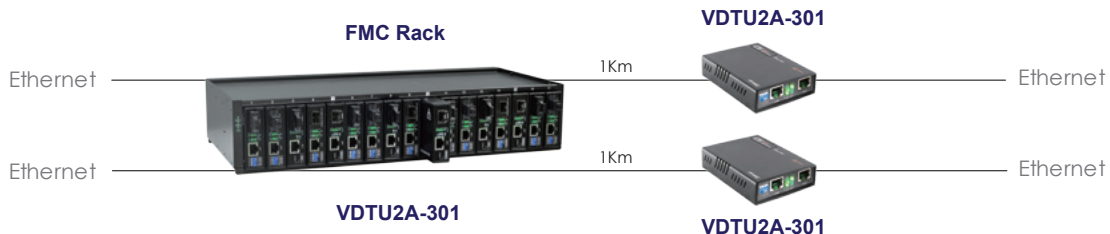

Standalone to Standalone Solution

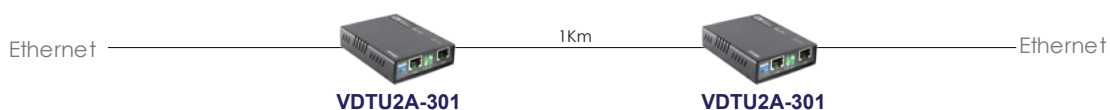

Ordering Information

Model Name	Description
VDTU2A-301	1x 10/100Base-TX LAN Extender
FMC-CH17-AC/DC/AD	2U, 17-slot FMC converter Chassis with AC, DC or AD Power

VDTU2A -
 Example: VDTU2A - 301

Chassis Power Type
 FMC-CH17 -
 Example: FMC-CH17 - AD



EFM-10/20/40

G.SHDSL bis EFM Modem with 4 Ports Ethernet

EFM is an Ethernet Network Extender designed to provide bonded high-speed Ethernet First Mile services over SHDSL on existing copper infrastructure. It is a bridge mode modem that delivers Ethernet services with symmetrical bandwidth at rates up to 22.8 Mbps (4 Pairs, Standard mode with TC-PAM 32) and 61 Mbps (4 Pairs, Enhanced mode with TC-PAM 128). Implemented on IEEE 802.3ah EFM standards for advanced performance and management features. EFM ensures high reliability, low expense and maximum throughput. The introduction of EFM copper bonding technology allows delivery of higher bandwidth to longer distances over multiple copper pairs, enabling a good alternative in place where fiber is not economical to deploy. This Ethernet-pure solution provides a seamless integration into today and tomorrow's networks. Designed with standard-based EFM technology (2BASE-TL), deployment of Ethernet services with EFM is quick and simple on the existing copper plant.

Feature

- Extending Ethernet Services to sites with existing copper infrastructure
- Supports TC-PAM 32 for 5.7 Mbps over single pair copper
- EFM Bonding up to 61 Mbps (4 pairs, TC-PAM 128)
- Flexible and Rapid Service Deployment
- Flexible configuration as CPE or CO
- Supports EFM OAM complying IEEE 802.3ah
- Low Delay, Jitter and packet loss for delay sensitive applications
- Comprehensive and easy OAM & P functions in provisioning and management
- QoS feature for guaranteed Ethernet service
- Future-proof Ethernet traffic management and QoS features

Specifications

Standards	LAN	4-Port switching hub 10/100Base-T auto-negotiation & sensing Auto MDI/MDI-X	Management Interface	Easy to use web-based GUI for quick setup, configuration and management Menu-driven interface for local console and telnet access Password protected management and access control list for administration SNMP v1/v2 (RFC1157/1901/1905) agent and MIB II (RFC1213/1493) EFM OAM (IEEE 802.3ah) Software upgrade via web-browser / TFTP
	WAN	ITU-T G.991.2.(2004) EFM bonding (IEEE 802.3ah OAM) 2BASE-TL Data Rate: • Nx 64 Kbps (N=3~89) using TC-PAM 16/32 • Max. 5.696Mbps (1-Pair) • Max. 11.392Mbps (2-Pair) • Max. 22.784Mbps (4-Pair) • N x 64 Kbps (N=3~239) using TC-PAM 64/128 • Max. 15.296 Mbps (1-Pair) • Max. 30.592 Mbps (2-Pair) • Max. 61.184 Mbps (4-Pair) • Supports of Annex A, Annex B, Annex AF & Annex BG		VLAN Support
LAN Protocols	802.1d Transparent Bridging Up to 2K MAC Address learning bridge		QoS Support	Rate limiting by rule-based/port-based Traffic classification based on port/802.1p/ DSCP WRR (Weighted Round Robin) / SPQ (Strict Priority Queuing) scheduling algorithm, IPv6 (RFC 5430) pass through
Hardware Interface	DSL : RJ-45 x 1, LAN : RJ45 x 4, Console Port x 1 MGMT : RJ45 x1, DC Power Jack x 1 Reset Button : Load Factory Default		Environment	Operating Temperature : 0 ~ 50°C Storage Temperature : -40 ~ 85°C Relative Humidity : 98%, non-condensing
Indicator	LAN : Link/Act, 10/100 per port System : Power, Alarm, MGMT WAN : Link per loop		Regulatory	ISO 9001 Quality Management, CE Approval
			Physical / Electrical	Dimension : 195 x 48 x 168mm (D x W x H) AC Power Adapter (100 ~ 240VAC) Weight : 1.3kg
			Memory	2MB Flash Memory, 8MB SDRAM

Application

Bandwidth Aggregation up to 22.8Mbps Over 4 pair of Copper wires

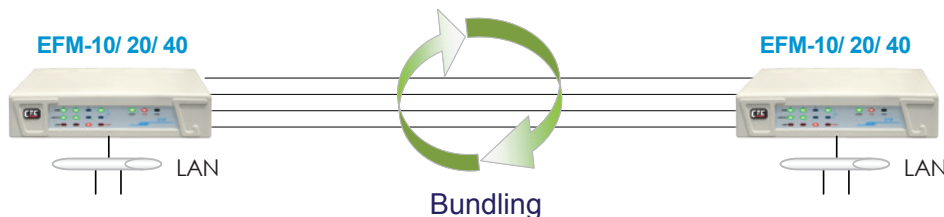

Ordering Information

Model Name	Description
EFM-10	2W, 2Base-TL, 4x10/100Base-TX G.SHDSL.bis EFM modem
EFM-20	4W, 2Base-TL, 4x10/100Base-TX G.SHDSL.bis EFM modem
EFM-40	8W, 2Base-TL, 4x10/100Base-TX G.SHDSL.bis EFM modem

EFM - □□
Example: EFM - 10



VDSM2-1524

24x VDSL2 IP DSLAM

VDSM2-1524 is a 24-port VDSL2 IP DSLAM with 2 Gigabit Ethernet Combo interfaces built-in a 1.5U height design. VDSM2-1524 offers the fastest data rate over the existing copper infrastructure. In order to connect with the growing broadband applications, VDSM2-1524 provides the idea solution in the last mile. VDSM2-1524 is able to provide a faster data transmission easily with the latest VDSL2 technology in order to handle the rapidly growing demands of triple-play media. VDSM2-1524 supports the switch management functions, such as port speed configuration, port link aggregation, IEEE 802.1Q VLAN, Q-in-Q VLAN, and ACL security. In addition, it is featured with advanced functions, such as IGMP snooping, QoS, bandwidth control and etc. VDSM2-1524 allows its users to provide a better secured network service with enforcing security policies, such as MAC filter, Static MAC, IP/MAC binding and port security.

Feature

- 1.5U design, 24 VDSL2 ports splitter
- Supports VDSL2 Profiles, 8a, 8b, 8c, 8d, 12a, 12b, 17a and 30a
- Supports Traffic Classification, such as QoS, ToS, DSCP, etc
- Supports L2/L3 Content Filtering
- Configuration backup and restoration
- Supports, Port-Based VLAN, Protocol-Based VLAN, VLAN Mapping, etc
- Supports L2 Bridge Functions (IEEE 802.1d) and Multicast.
- DHCP Server/Relay/Client
- DNS Proxy
- Flexible Deployment and Maintenance.
- Web-based management with a user friendly interface
- Supports MTU 1790 bytes

Specifications

Chassis	1.5U High
Interfaces	24 VDSL2 Ports Two RJ-45 100/1000Mbps Ethernet Combo Ports Management Ethernet 1 x RS-232 Serial Console POTS Splitter
LED Indicators	SYS, ALM, LINK, ACT 24 x VDSL LEDs
Standards	VDSL2 ITU-T G.993.2 VDSL2 Profiles: 8a, 8b, 8c, 8d, 12a, 12b, 17a and 30a 802.1d L2 Bridging DHCP Server/Client/Relay IEEE 802.1Q VLAN (Port-based VLAN and Protocol-Based VLAN) VLAN Stacking (Q-in-Q) IEEE 802.1p Spanning Tree Protocol (STP) IEEE 802.3ad Link Aggregation
Protocols	IGMP Snooping/Proxy v1 and v2 Multicast Forwarding with IGMP Snooping v1 and v2 (RFC 1112 and RFC 2236)

Protocols	Up to 512 Multicast Channels Fast and Normal Leave Modes
Security	L2 Frame Filtering by MAC Addresses L3 Frame Filtering by IP Addresses, protocol ID, and TCP/UDP DHCP and ARP Broadcasting Frames Filtering Supports Secured Forwarding
Management	Supports OAM&P Functions Supports VLAN Priority Queue (IEEE 802.1p) Supports CoS, ToS, DSCP, etc. Supports SNMP v1/v2/v3 and MIB I/II Web-based Graphical User Interface, Telnet, CLI and SSH
Environment	Operating Temperature : -10 ~ 50°C Storage Temperature : -40 ~ 70°C Relative Humidity : Up to 95% (non-condensing)
Power	100-240V AC, 50-60Hz
Power Consumption	90Watts (max.)
Dimensions	435x260x67mm, 1.5U height
Regulatory Compliance	CE, FCC Part 15 Subpart B, VCCI, EN60950

Application

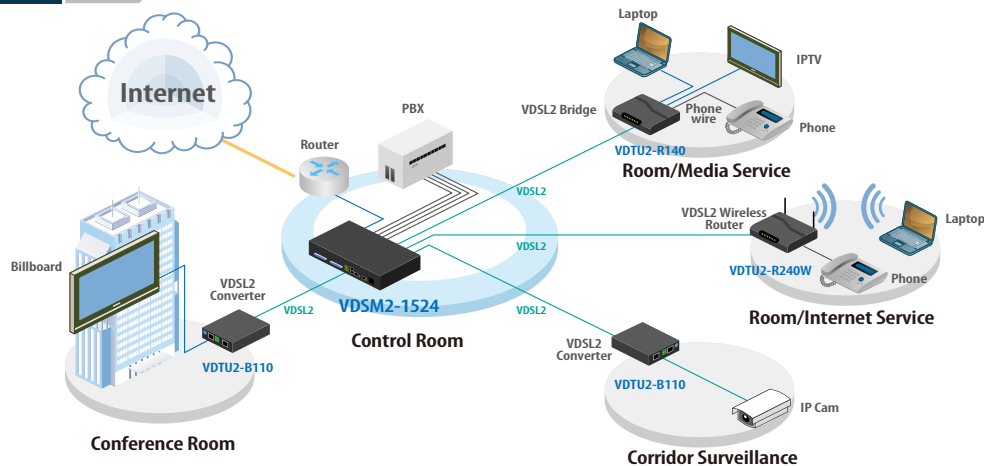

Ordering Information

Model Name	Description
VDSM2-1524	24-Port VDSL2 IP DSLAM with POTS Splitter (600 ohm)



VDSM2-1008

8x VDSL2 IP DSLAM

VDSM2-1008 is a compact 8-port VDSL2 IP DSLAM with 2 Gigabit Ethernet Combo interfaces and built-in POTS splitter. It is compliant to ITU-T G.993.2 standard and supports VDSL2 30a profile that features 100Mbps of symmetric data rate over the existing copper wires. VDSM2-1008 is an ideal choice for ISPs and System Integrators that are looking for a high performance broadband solution for their triple play (Video, Voice and Data) applications. VDSM2-1008 is designed to connect with the growing Carrier Ethernet infrastructure, it provides great flexibility for service providers to customize their services and brings them reliable, secure and high quality network access at low cost. In addition, VDSM2-1008 offers user-friendly management interfaces that allow service providers to monitor and control their services in a highly secure and efficient way. It features the supports for Port-based/ Protocol-based VLAN, Q-in-Q, VLAN Mapping, VLAN translation, L2/L3 frame filtering and secured forwarding. Furthermore, VDSM2-1008 supports traffic classification including CoS (802.1), VLAN ID, ToS and DSCP. With all these powerful and advanced features, VDSM2-1008 VDSL2 Mini IP DSLAM is the perfect solution for service providers to deploy their broadband access, IP Surveillance, Hospitality and MTU/MDU applications.

Feature

- 1U design, 8 VDSL2 ports with POTS splitter
- Provides 3-FAN cooling mechanism and support low/middle/full speed based on programming temperature
- Supports VDSL2 profiles 8a/8b/8c/8d/12a/12b/17a/30a
- Supports traffic classification, such as QoS, ToS and DSCP
- Supports Port Security with MAC address filtering
- Supports Port-Based VLAN, Protocol-Based VLAN and VLAN Mapping
- Supports IEEE 802.1d STP/IEEE802.1w RSTP & IEEE-802.1s MSTP
- DHCP /Client/Relay/Option82, DNS Proxy
- Flexible deployment and maintenance
- Web-based management with a user friendly interface
- Configuration backup and restoration
- Supports MTU 1790 bytes

Specifications

Interfaces	RJ-11 x 8 VDSL2 Ports / RJ-11 x 8 POTS Ports 2x Gigabit Ethernet Combo ports (100/1000Base-T and SFP) 1x RJ-45 Console Port 1x RJ-45 Alarm Port for 4 Alarm Inputs	Power Consumption	30Watts maximum
LED Indicators	System : PWR Gigabit Port : LINK/ACT, SPEED 1000/100 Alarm : RUN/ALARM VDSL : VDSL Link/Sync	Protocols	IGMP Snooping/Proxy v1, v2 and v3 Multicast Forwarding with IGMP Snooping v1 and v2 (RFC 1112 and RFC 2236) Multicast MAC address mapping Up to 512 Multicast Channels Profile-based Multicast Access Control (up to 8 profiles) Fast and Normal Leave Modes
Standards	VDSL2 ITU-T G.993.2 VDSL2 Profiles: 8a, 8b, 8c, 8d, 12a, 12b, 17a and 30a 802.1d L2 Bridging DHCP/Client/Relay/Option82 IEEE 802.1q VLAN Tag base VLAN Stacking (Q-in-Q) IEEE 802.1d Spanning Tree Protocol (STP) IEEE 802.3ad Link Aggregation	Security	L2 Frame Filtering by MAC Addresses L3 Frame Filtering by IP Addresses, protocol ID, and TCP/UDP DHCP and ARP Broadcasting Frames Filtering Supports Secured Forwarding
Certification	CE, FCC Part 15 Subpart B, VCCI, EN60950	Management	Local Management: RS-232 and Telnet CLI, Web/SNMP management Remote in-band Management: Web/SNMP/Telnet Supports SNMP v1/v2/v3
Dimensions	174 x 404 x 44.5 mm (D x W x H)	Environment	Operating Temperature : -10°C to 50°C Storage Temperature : -40°C to 70°C Humidity : 10% - 95% (non-condensing)
Power	100-240 V AC, 50-60 Hz		

Application

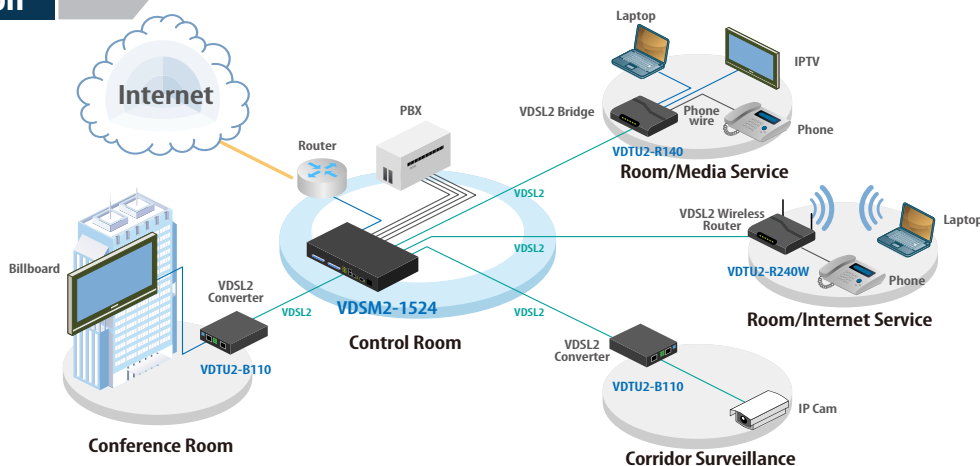

Ordering Information

Model Name	Description
VDSM2-1008	8-Port VDSL2 IP DSLAM with POTS Splitter (600 ohm)



VDTU2-R240W

VDSL2 802.11n Wireless Router

VDTU2-R240W is a VDSL2/ADSL2+ 802.11n Wireless router with four fast Ethernet LAN ports and USB Host. It is compliant to ITU-T G.993.2 standard and supports VDSL2 30a profile that features 100Mbps of symmetric data rate over local loop. With built-in 802.11n technology, VDTU2-R240W can deliver wireless speed up to 300 Mbps and is perfectly suitable for triple play applications (video, voice and data). VDTU2-R240W VDSL2 Router is designed to meet the requirements of ISPs and carriers that intend to use one DSL device to cover end users in different loop range areas, it provides a great flexibility for their end-users to comply today's rapid-changing Internet demands. VDTU2-R240W VDSL2 is a cost-effective and high-speed Internet access solution that can provide users a smooth and reliable wireless connection.

Feature

- Automatically switches from VDSL2 to ADSL2+
- Supports VDSL2 profiles 8a/8b/8c/8d/12a/12b/17a/30a
- Equipped with a one-click Wi-Fi Protected Setup (WPS) button
- Security protection with firewall
- Supports MTU 1790 bytes
- Web-based management with user friendly interface.
- Configuration backup and restoration
- TR-069 Remote Management (Optional)

Specifications

Interfaces		WLAN	Compliant with IEEE 802.11b, 802.11g, and IEEE 802.11n standards 2.4 GHz configurable (5 GHz Optional) Up to 300 Mbps wireless operation rate RF Output Power: 15 ± 1.5 dBm in 2.4 GHz 64/128-bit Wireless security with WPA/WPA-PSK, PA2/WPA2-PSK, Mixed WPA/WPA2 support WPS (WiFi Protected Setup) for easy setup
LAN	4x RJ-45 10/100Base-TX Auto-sensing and Auto-MDIX switch, supports IPv6	USB	File Sharing 3G backup support
USB	USB host x 1	VPN	VPN Pass-through
Wi-Fi	802.11b/g/n and 2 External antennas	Management	Web-based GUI for remote and local management (HTTP/HTTPS) Quick Start Wizard Configuration Backup and Restoration Firmware upgrade through TFTP/FTP and HTTP SNMP management with SNMP agent and MIB II Supports Syslog TR-069 (Optional)
RST	"Factory reset" button & reboot button	QoS	ATMQoS : UBR (Default), CBR, VBR-rt, VBR-nrt 802.1p IP DSCP
WPS	WPS push button	Firewall	IPv6 Firewall Packet filtering URL filtering Parental control
Power	ON/OFF switch	Routing	Static routing and RIP v1/v2 (RFC 1058/2453) Supports IP/TCP/UDP/ARP/IGMP IP multicast and IGMP proxy (RFC 1112/2236) Network Address Translation (NAT/PAT) DNS relay and caching (RFC 1034/1035) DHCP server IP precedence (RFC 791) (Firewall router)
DSL Compliance		Power	AC Adapter : 100V-240V± / 10% Output : DC 12VDC
ADSL	G.dmt (ITU G.992.1) Annex A, B G.lite (ITU G.992.2) Annex A, B G.hs (ITU G.994.1) G.bond (ITU G.998.1) Maximum rate : 8 Mbps for downstream / 1 Mbps for upstream G.dm.bist + A196 (ITU G.992.3) Annex A, B G.lite.bis (ITU G.992.4) Annex A, B Maximum rate : 12 Mbps for downstream / 1 Mbps for upstream G.dmt.bisplus (ITU G.992.5) Annex A, B Maximum rate : 24 Mbps for downstream / 1,2 Mbps for upstream	Certification	CE, FCC, RoHS compliant
ADSL2+	Up to 8 PVCs Supports encapsulation of bridged Ethernet over AAL5 (RFC 2684, formerly RFC1483) Supports encapsulation of routed IP over Ethernet over AAL5(IPoE) Supports encapsulation of routed IP over AAL5 (IPoA) Supports Classical IP according to RFC 2225 (formerly RFC1577) Supports PPPoA according to RFC 2364 Supports PPPoE(default) according to RFC 2516 Supports multiple levels of QoS		
VDSL2	ITU G993.2 Annex A, B, C VDSL2 (ITU G993.2) Annex A,B,C, support Band plans 997, 998 refer to Annex B Up to 17 Mhz profile (POTS/ISDN) Supports VDS2 profile 8a, 8b, 8c, 8d, 12a, 12b, 17a, 30a Supports ATM and PTM transparent (dual-priority & dual latency) for user data		

Application

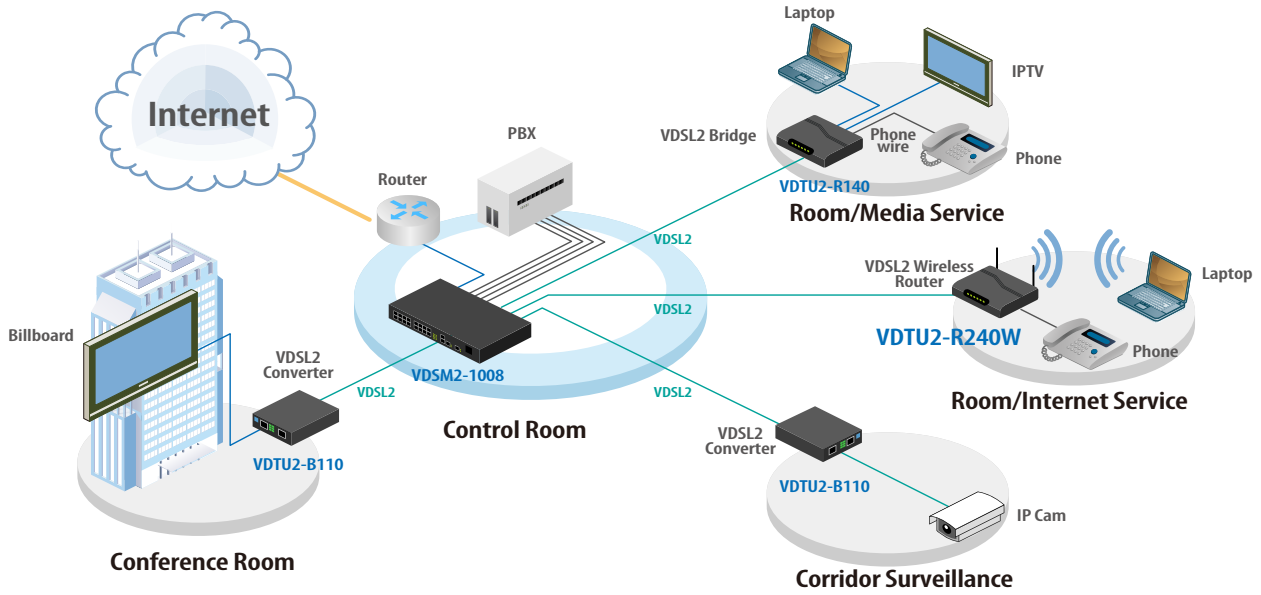

Ordering Information

Model Name	Description
VDTU2-R240W	VDSL2 Wi-Fi Router with 4-Port 10/100-TX Ethernet



VDTU2-R140

VDSL2 Router with 4-Ports Ethernet

VDTU2-R140 is a single-VDSL2-port router with 4x 10/100Mbps Ethernet ports. It adopts the latest VDSL2 technology (ITU G.922.3), which has the extraordinary bandwidth and supports up to VDSL2 profile 30a, and it is perfectly suitable for triple play applications (video, voice and data). VDTU2-R140 is a cost effective solution that delivers high-speed Internet access to end-users over existing copper wire infrastructure. Also, it is designed to meet the requirements of ISPs and carriers that intend to use one DSL device to cover end users in different loop range areas. In addition, it provides great flexibility for their end-users to comply today's rapid-changing Internet demands. Based on the latest VDSL2 technology, VDTU2-R140 presents a cost-effective solution with high-speed Internet access over standard copper telephone cable.

Feature

- Supports point-to-point mode (support both CO and CPE modes)
- Interoperable with major VDSL2 chipset solutions including Ikanos, Infineon, and Broadcom
- Supports up to VDSL2 profile 30a
- Supports up to 100Mbps for both Upstream and Downstream
- Built-in UPnP available, which allows automatic discovery and the broadband router's configuration
- IP/MAC address filtering
- Static route/RIP/RIP v2 routing functions
- Dynamic IP assignment
- Supports QoS to enhance traffic efficiency
- Supports NAT, which allows multiple users access the Internet with only one single external IP address
- IGMP Proxy and fast leave
- DHCP Server/Relay/Client. DNS Proxy, DDNS
- Embedded SNMP agent
- Web-based management with a friendly graphical user interface
- Configuration MTU backup and restoration
- Supports MTU 1790 bytes

Specifications

Standards	Compliant with ITU VDSL2 standard G.993.2 Annex A, Annex B and Annex C Supports VDSL2 profile: 8a, 8b, 8c, 8d, 12a, 12b, 17a and 30a Band plan profile: symmetric (Plan 997) and asymmetric (Plan 998) Built-in POTS splitter to share voice and data (Optional)
Management	Web-based GUI for quick setup, configuration and management Firmware upgradable from Web SNMP management with SNMP agent and MIB II
Interfaces	Ethernet: 4 X RJ-45 connectors for Ethernet 10/100Mbps ports with Auto-MDI/MDIX VDSL: 1 X RJ-11 connector for VDSL2 port
QoS	Port Based 802.1p ToS/DSCP 4 priority queues per port WRR/WFQ/SP/BE
Power	AC Adapter : 100V-240V± / 10% Output : DC 12VDC

LAN	Filtering functions for MAC/IP/Port. Port Based VLAN & IEEE 802.1q VLAN Tagging Port configuration for Bandwidth/Duplex/Speed/Flow control
Routing	Static routing and RIP v1/v2(RFC 1058/2453) Support IP/TCP/UDP/ARP/IGMP IGMP snooping and proxy (RFC 1112/2236) NAT ALGs for ICQ/NetMeeting/MSN/Yahoo Messenger DNS relay and caching (RFC 1034/1035) DHCP server, client and relay (RFC 2131/2132) Dynamic DNS IP precedence (RFC 791) (Firewall router)
Firewall	DMZ host Virtual server mapping (RFC1631) VPN pass-through for PPTP/ L2TP/ IPSec tunneling NAT firewall User access control
Weight	300g
Dimensions	131.5 x 180 x 36.5 mm (D x W x H)

Application

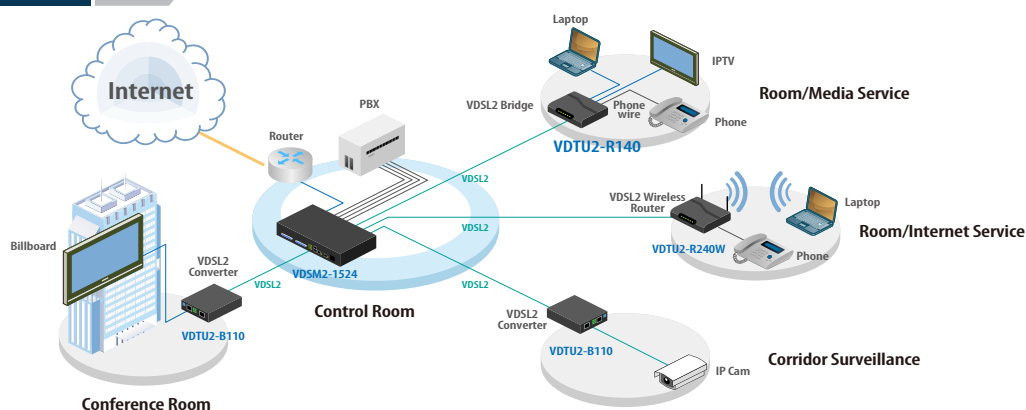

Ordering Information

Model Name	Description
VDTU2-R140	VDSL2 Router with 4-Port Ethernet and POTS splitter (600 ohm)



VDTU2-B110

VDSL2 Ethernet Bridge

VDTU2-B110 Ethernet Extender is a high-speed Ethernet Extender with one Ethernet port (RJ-45 connector) and one VDSL port (RJ-45 connector). It is a bridge mode modem, well accommodating VDSL2 (Very-high-data-rate Digital Subscribe Loop) technology to extend Ethernet service over single-pair phone line. It is compliant to ITU-T G.993.2 standard and supports VDSL2 30a profile that features 100Mbps of symmetric data rate over the existing copper wires. Supporting both symmetric and asymmetric transmission, it can reach up to 100/100 Mbps bandwidth (line rate) within 300M or 10/10 Mbps (line rate) for 1 Km long range connections. By providing ultra-high speed, VDTU2-B110 Ethernet Extender makes your telephone line achieve its best performance than before. It has the advantage of minimum installation time (simply as plug-n-play) and minimum expense by allowing video streaming and data to share the same telephone pair without interference.

VDTU2-B110 Ethernet Extender delivers everything needed to quickly deploy a high-speed IP-based network for providing high-speed Internet access, video-on demand services and voice services. The resulting compact, cost-effective form factor offers Systems Integrators, small business owners an attractive Long Reach Ethernet solution.

Feature

- Cost effective bridge function to connect two Ethernet LAN
- Supports flow control on Fast Ethernet port via PAUSE frame or Back Pressure
- IEEE 802.1Q VLAN tag transparent
- Easy installation via simple plug-and-play
- Selectable CPE and CO mode via DIP switch: Two working modes are built in the same unit, which keep the flexibility of installation and easy provision of service but lower inventory of service provider
- Selectable VDSL2 profile mode (17a or 30a): Support up to VDSL2 30a profile to ensure high data rate.
- Selectable target band plan:
Symmetric: Support the band plan G.997 and provide the symmetric transmission on both downstream and upstream.
Asymmetric: Provides highest line rate in short range in asymmetric mode.
- Selectable target SNR margin

Specifications

4-Pole DIP Switch	Selectable CO or CPE mode Selectable 30a or 17a (VDSL2 Profile) Selectable Band plan (Symmetric or Asymmetric) Selectable target SNR margin (6dB or 9dB)	VDSL Interface	RJ-45 connector DMT Encoding Complies with ITU-T G993.1/993.2/G.997.1 On-board surge protection
LAN Interface	RJ-45 connector Complies with IEEE 802.3/802.3u/802.3x 10/100 Base-T Auto-Negotiation, Auto-MDI/MDI-X	Dimensions	73.4 x 96.2 x 22.8 mm (D x W x H)
LED	LAN : ACT/LNK, 10/100Mbps, Half/Full Duplex VDSL : Power On/Off, CO/CPE, Idle/Trained/Link	Temperature	0°C ~45°C
Power supply	DC 12 Volt over 3.5mm DC jack ; 4.2 Watt maximum	Humidity	0%~95%RH (non-condensing)
		Certification	CE FCC Part 15 Class B EN60950

Application



Ordering Information

Model Name	Description
VDTU2-B110	VDSL2 10/100-TX Ethernet Bridge
FMC-CH17-AC/DC/AD	2U, 17-slot FMC converter Chassis with AC, DC or AD Power

VDTU2 -
 Example: VDTU2 - B110
 Chassis Power Type
 FMC-CH17 -
 Example: FMC-CH17 - AD

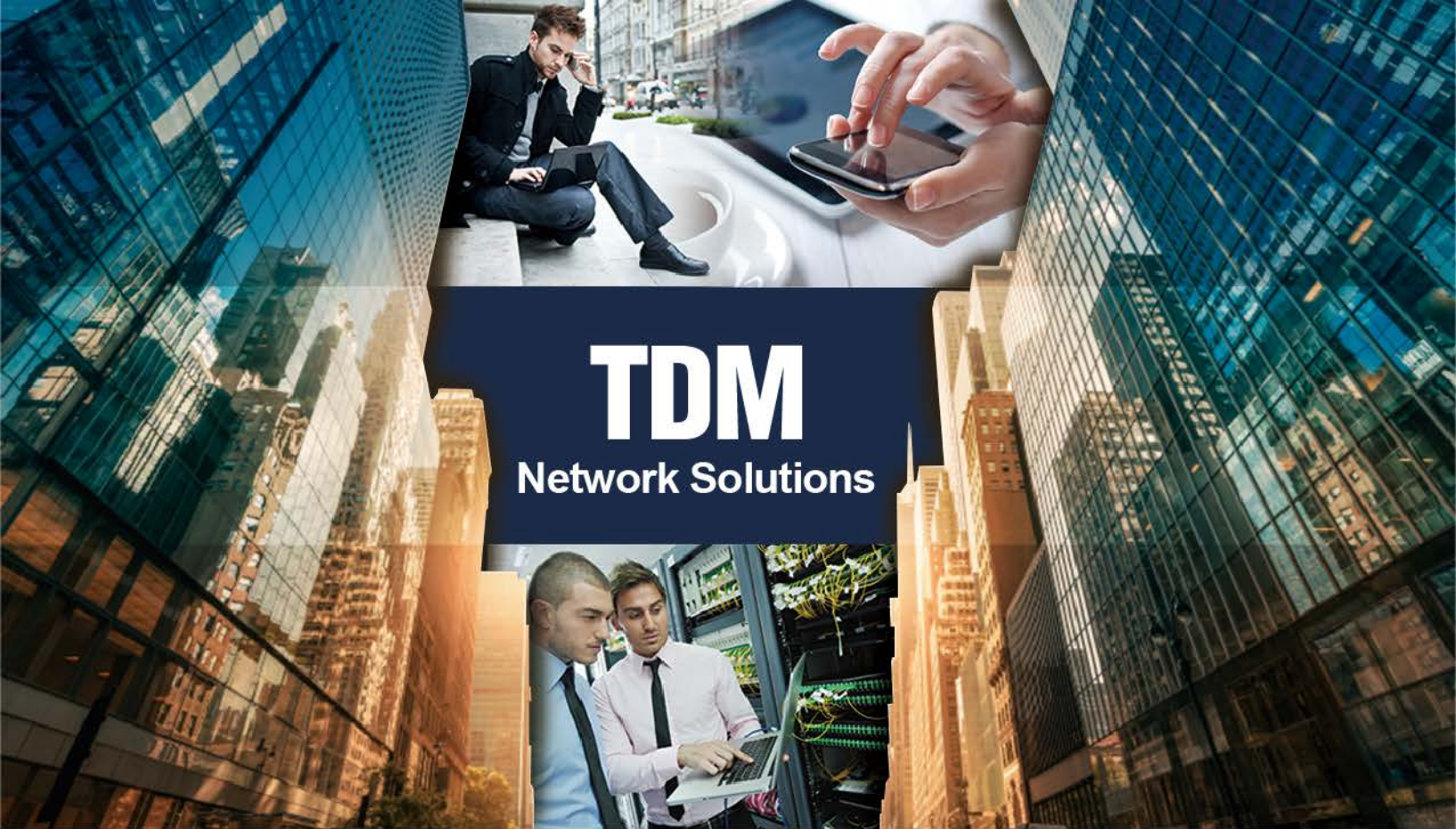

TDM

Network Solutions

STM1/E1 Access Multiplexer
E1 Access Unit/Multiplexer
Ethernet Bridge

VDSL2 IP DSLAM
VDSL2 Bridge/Router
EFM LAN Extender

E1 TDM over IP
Ethernet Serial Server





iSAP5100

STM1/E1, Data, Ethernet, Voice Managed Multiplexer (4.5U)

The iSAP5100 is a 5U 19" 20 slots rack type STM1 / E1 Time Division Multiplexer for fractional E1 network access, which is designed for non-stop operation. There are 18 slots available for hot-swappable iSAP5100 I/O cards. Two slots are provided for CPU Controller cards and two slots are provided for power supplies. Uplink supports STM1 fiber and E1 copper, two types of connection, maximum up to 144x E1 cross connect for Voice and Data. The iSAP5100 accommodates up to two separate power supplies, which may derive power from AC (110/220) or DC (-36~72V) power sources. When two power supplies are installed, the modules provide complete power redundancy and are hot swappable even during the E1 cards' transmission. The iSAP5100 provides STM1 fiber and E1 copper uplink with a the maximum E1 support of up to 96 E1 channels with cross connection for Voice and Data or interface including RS232, V.35, G64K, FXS, FXO, ET100 and E&M.

Interface Cards

- Control card: 5100-MS-DM-96, 5100-MS-DM-155
- E1 card: 5100-8E1, 5100-16E1
- Power modules: 5100-AC240, 5100-DC240
- I/O cards: 5100-RS232, 5100-RS232/C, 5100-G64K, 5100-V35, 5100-ET100, 5100-E&M, 5100-FXS, 5100-FXO

Feature

- Supports MAX. 96x E1 with full cross-connect, Supports DS0 cross-connect
- Supports 16 channel Main E1 LTU card
- Supports E1 time slot broadcast function
- Modular design for Voice I/O card, the voice I/O card has two sub-module, each sub-module supports 4-port FXO/FXS
- All modules and cards support hot-swapping
- DCE card types included N x 64K, RS232(Sync/Async), G703-64K, ET100, E&M, FXO, FXS...etc.
- Supports Console, Telnet, SNMP and GUI management
- Available types of power built-in : AC+AC, AC+DC, DC+DC
- Modular design, 5U 19", 18-slot for I/O cards

Specifications

5100-MS-DM-96	
Interface	10/100Base-TX Ethernet RJ45 port
Console	RS232
E1 Cross Connect	144xE1 Transparent cross connect , Supports E1 time slot mapping / broadcast function
CAS Cross Connect	Supports 16 time slot CAS follow voice time cross connect
5100-MS-DM-155	
Interface	Supports 1-port STM-1 155M SFP Slot on CPU card, CPU redundancy (1+1)
NMS	10/100Base-TX
Console	RS232
E1 Cross Connect	155M fiber to 63E1 and 144xE1 cross connect, supports E1 /time slot mapping/broadcast function
CAS Cross Connect	Supports time slot 16 CAS follow voice time cross connect
STM-1/E1 Drop / Insert	Supports STM-1 63E1 x 32TS to E1/IO slot 128E1 x 32TS connection
5100-8E1 / 5100-16E1	
Interface	Supports 8E1/16E1 interface
Line Impedance	120 / 75 ohms
Frame format	CAS (PCM30)/CCS (PCM31)
Connector	RJ45
5100-RS232	
Data rate	≤38.4kbps Async or 64/128kbps Sync
Ports	6-port
Interface	RS232
5100-V35	
Interface types	V.35
Connector	HD68F (female) with cable adapter
Line code	NRZ
Data rate	Nx64kbps
5100-RS232/C	
Data rate	9600bps, 19.2Kbps Sync/Async
Ports	6-port

Interface	RS232
5100-G64K	
Data rate	64Kbps, Co-directional/Contra-directional and Centra-directional
Ports	4-port
Connector	RJ45
5100-ET100	
Standards	IEEE 802.3, 802.3u
MDI/MDIX	Auto
Data rate	10/100Mbps
Encapsulation	HDLC
Ports	4-port
Connector	RJ45
5100-E&M	
Loop current	25 mA, maximum 70mA
Ports	8-port
Connector	RJ45
5100-FXS	
ITU-T Standard	G.712/G.713/G.714
Line resistance	600Ω
Off-hook current	25mA
Line distance	2km
Ports	8-port
On-hook current	10mA+/-3mA
Effective Ring	Frequency: 25Hz, Voltage: 75V, peak to peak110V MAX line resistance: 1500Ω
Connector	RJ45
Electrical & Mechanical	
Dimensions	350 × 440 × 187 mm (D x W x H)
Environmental	Operating: 0~60°C Storage:-25~70°C Humidity: 10~90%, non-condensing
Power	AC 220V : 165~265V, 50~60Hz, DC -48V:-36~-76VDC
Power Consumption	< 90W



iSAP2000

E1, Data, Ethernet, Voice Managed Multiplexer (2U)

The iSAP2000 is a 2U 19" 6 slots rack type E1 Time Division Multiplexer for fractional E1 network across, which is designed for non-stop operation. There are 6 slots available for hot-swappable I/O cards and two slots are provided for power supplies. Uplink supports E1 copper connection, maximum up to 96x E1 cross connect for Voice and Data. The iSAP2000 optionally accommodates up to two separate power supplies, which may derive power from AC (110/220) or DC (-36~72V) power sources. When two power supplies are installed, the modules provide complete power redundancy and are hot swappable even during the E1 cards' transmission. The iSAP2000 provides E1 copper uplink, the maximum E1 supports up to 96 E1 channels with cross connection for Voice and Data, the interface included RS232, RS485, G64K, V35, FXS, FXO, ET100 & E&M.

Interface Cards

- E1 card: 5100-8E1, 5100-16E1
- Power modules: 2000-AC240, 2000-DC48
- I/O cards: 5100-RS232, 5100-RS232/C, 5100-N*64K/V35, 5100-G64K, 5100-ET100, 5100-E&M, 5100-FXS, 5100-FXO, 5100-RS485

Feature

- Supports MAX. 96xE1 with full cross-connect, Supports DS0 cross-connect
- Supports 16 channel Main E1 LTU card
- Supports E1 time slot broadcast function
- Modular design for Voice IO card, the voice IO card has two sub-module, each sub-module supports 4-port FXO/FXS
- All modules and cards support hot-swapping
- DCE card types included N*64K, RS232(Sync/Async), G703-64K, ET100, E&M, FXO, FXS...etc.
- Supports Console, Telnet, SNMP and GUI management
- Available types of power built-in : AC+AC, AC+DC, DC+DC
- Modular design, 2U 19", 6-slot for I/O cards

Specifications

Management	
NMS	10/100Base-TX
Console	RS232
5100-8E1, 5100-16E1	
Interface	Supports 8E1, 16E1 two types interface
E1 Cross connect	96xE1 transparent cross connect, supports E1, time slot
CAS cross connect	Supports 16 time slot CAS follow voice time cross connect
Line Impedance	120 / 75 ohms
Frame format	CAS(PCM30)/CCS(PCM31)
Connector	RJ45
5100-RS232	
Data rate	≤38.4kbps Async or 64/128kbps Sync
Ports	6-port
Interface	RS232
5100-RS232/C	
Data rate	9600bps, 19.2Kbps Sync/Async
Ports	6-port
Interface	RS232
5100-N*64K/V35	
Data rate	Nx64kbps(N=1~30 or 31)
Ports	4-port
Connector	V35 Interface
5100-G64K	
Data rate	64Kbps, Co-directional, Contra-directional and Centra-directional
Ports	4-port
Connector	RJ45
5100-ET100	
Standards	IEEE 802.3, 802.3u
MDI/MDIX	Auto
Data rate	10/100Mbps
Ports	4-port
Connector	RJ45

5100-E&M	
Loop current	5~30 mA, maximum 70mA
Ports	8-port
Connector	RJ45
5100-FXS	
ITU-T Standard	G.712, G.713, G.714
Line resistance	600Ω
Off-hook current	25mA
Line distance	2km
Ports	8-port
On-hook current	10mA+/-3mA
Effective Ring	Frequency: 25Hz Voltage: 75V, peak to peak110V MAX line resistance: 1500Ω
Connector	RJ45
5100-FXO	
ITU-T Standard	G.712, G.713, G.714
Line resistance	600Ω
Line distance	2km
Ports	8-port
Caller ID	Supports DTMF, FSK Standard
Connector	RJ45
Electrical & Mechanical	
Dimensions(WxDxH)	440mmx300mmx88mm
Environmental	Operating: 0~60°C Storage: -25~70°C Humidity:10~90%, non-condensing
Power	AC 220V: 165~265V, 50~60Hz DC -48V:-36~-76VDC
Power Consumption	< 40W

Application

Connection with PBX (Private Branch Exchange)

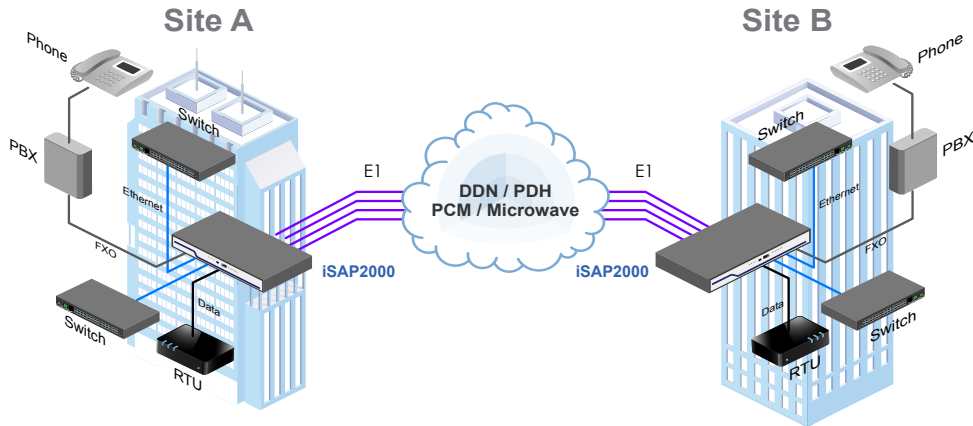

The extension and expansion of DDN (Distributed Data)

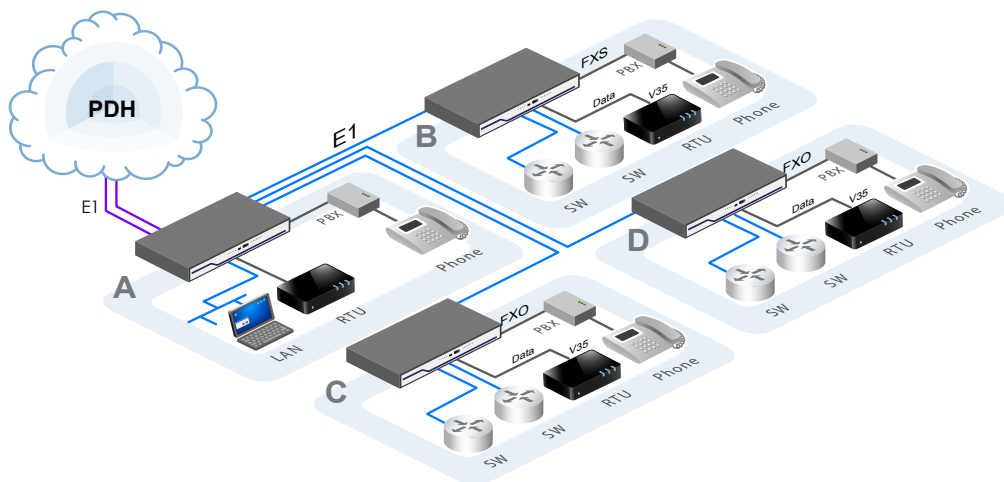

Ordering Information

Model Name	Type	Description
iSAP2000-CH	Chassis	2U 19" 6 slots Chassis with built-in CPU card, power modules not included
iSAP2000/AC	Power	AC power plug-in module (165 to 265 VAC)
iSAP2000/DC	Power	DC power plug-in module (± 36 to ± 76 VDC)
iSAP-EMS	Software	EverLink2000 EMS software for iSAP5100 and iSAP2000
iSAP5100-8E1R	Main E1 card	8 channels Main-E1 LRU card: Fractional E1 RJ45
iSAP5100-16E1R	Main E1 card	16 channels Main-E1 LRU card: Fractional E1 RJ45
iSAP5100-CAB-RJ45/4BNC	Cable	2ch E1 RJ45 to 4BNC cable (1.5 meter)
iSAP5100-FXO	Voice Card	8 channels FXO interface card
iSAP5100-FXS	Voice Card	8 channels FXS interface card
iSAP5100-E&M	Voice Card	8 channels 2/4 wires E&M voice interface card
iSAP5100-RS232	RS-232 card	6 channels RS-232 interface card (V4.0), Low speed: 128kbps 19.2kbps Async
iSAP5100-RS232C	RS-232 card	6 channels RS-232 (V.24) interface card, Low speed: 128kbps, 19.2kbps Async with Multi-Clock function
CAB-DB62DB25F6-232-LS	Cable	RS-232 adapter cable for low speed: DB62 Male to 6x DB25 Female, 1M
iSAP5100-ET100	FE Card	4 channels 10/100Base-TX Ethernet Bridge card
iSAP5100-DATA	Data card	4 channels V.35/X.21/RS530/RS449 cards
CAB-HP68MB34F4-V35	Cable	V35 adapter cable for High speed: HP68 Male to 4x MB34 Female, 1M
CAB-HP68DB25F4-530	Cable	RS530 adapter cable for High Speed: HP68 Male to 4x DB25 Female, 1M
CAB-HP68DB15F4-X.21	Cable	X21 adapter cable for High speed: HP68 Male to 4x DB15 Female, 1M
CAB-HP68DB37F4-449	Cable	RS449 adapter cable for High Speed: HP68 Male to 4x DB37 Female, 1M
iSAP5100-G64K	64K co-directional Card	4 channels G.703 64kbps co-directional card

Chassis
iSAP2000 –
 Example: iSAP2000 – CH

Card Type
iSAP2000 –
 Example: iSAP2000 – 8E1R



iSAP1000

STM1/E1 Access Multiplexer

iSAP1000 is 1U 19" rack type STM-1/E1 terminal multiplexer which delivers traditional PDH services over SDH networks. iSAP1000 provides connectivity for up to 16E1. The product complies with SDH standards and interfaces with existing SDH backbones through a single or 1+1 protection STM-1 interface. iSAP1000 supports a variety of management access over console, and SNMP. iSAP1000 provides two Gigabit Combo ports (2-port 10/100/1000Base-T and 2-port 1000Base-X SFP slot) with 16x E1 or 2x STM-1 fiber interfaces. The two GE combo ports support Link aggregation, port based VLAN and 802.1Q VLAN function.

Feature

- Provides 2-port STM-1 fiber with 1+1 protection.
- Supports Internal clock and recovery clock modes
- Supports Single E1 fractional and unframed E1 service; Multiple E1, fractional E1
- Supports PCM31, FAS+CRC4, CRC self-test
- Supports HDLC/GFP bridge operation, 16x VCG with total 16 remote device, 16E1 Per VCG, MAX 63E1 non-blocking matrix
- Supports 16E1 balanced RJ45 or unbalanced BNC connectors
- Maximum 220ms delay variance between E1 links
- Supports 2x GbE Combo ports
- Supports IEEE 802.1Q VLAN and QinQ, Link aggregation
- Fiber port support ALS(Auto Laser Shutdown) function
- Built-in BERT for performing local and remote loopback
- Supports Console, GUI and SNMP management
- Supports local and remote FTP/TFTP f/w upgrade
- Support for LCAS according G.7042
- Support according to G.7043 VCAT
- Hot Standby mode for power supply
- E1 ports faults statistics monitoring
- Complies with ITU-T G.8040 standard
- Supports MTU 1522 bytes

Specifications

Ethernet Interface	Supports 2x GE combo ports Auto Negotiation, AUTO-MIDX, 10M/100M/1000M, Full/Half Duplex Connector : RJ45	Management port	One console port with RJ45 connector One SNMP Ethernet port with RJ45 connector
Optical Interface	Supports 802.3x flow control 1000FX, SFP Connector : LC	LED Indicators	SYS, PWR, PWR1, PWR2, GE(LNK/ACT, SD), E1(LOS, SYNC)
E1 Interface	Up to 16x E1(ITU-T G.703) Line Impedance : 75ΩBNC or 120ΩRJ45 Bit rate : 2048kbps±50ppm Line code : HDB3	Standards	IEEE802.3 Ethernet, IEEE802.3u, IEEE802.3Z, IEEE802.3X, IEEE802.1Q, IEEE802.1ad, SNMPv1/v2c/v3, ITU-T G.703, ITU-T G.704, ITU-T G.823
STM-1 Interface	Supports 2x STM-1 optical fiber port with SFP slot Supports 1+1 optical fiber protection	Dimensions	310 x 440 x 44mm (D x W x H)
		Power	AC: 90-265V, DC: -48V, Supports AC+AC, DC+DC, AC+DC
		Power Consumption	<24W
		Temperature	Operating: -5 ~ 50°C Humidity : ≤90% non-condensing

Application

P to P, GE over 16E1 application

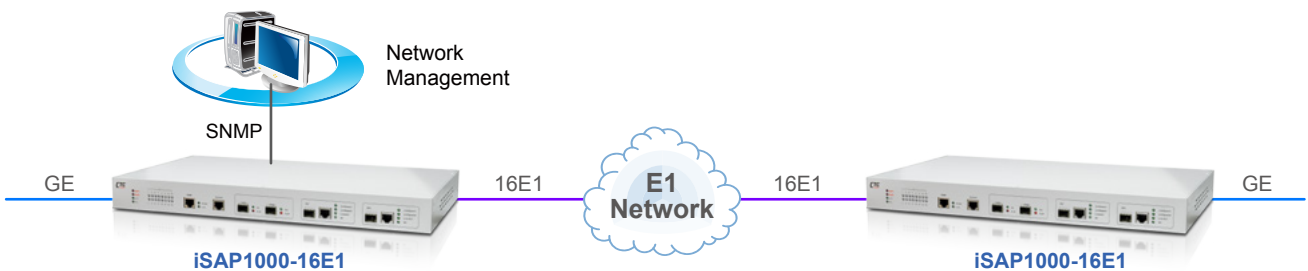

STM1/E1 Access Multiplexer

Point to Multi-points 16E1 aggregation

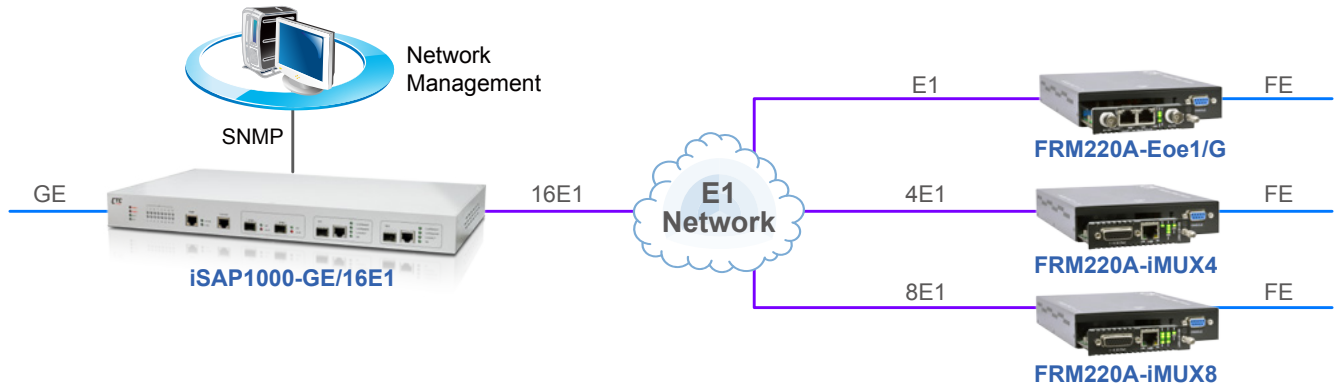

Point to Multi-points 63E1 aggregation over STM-1

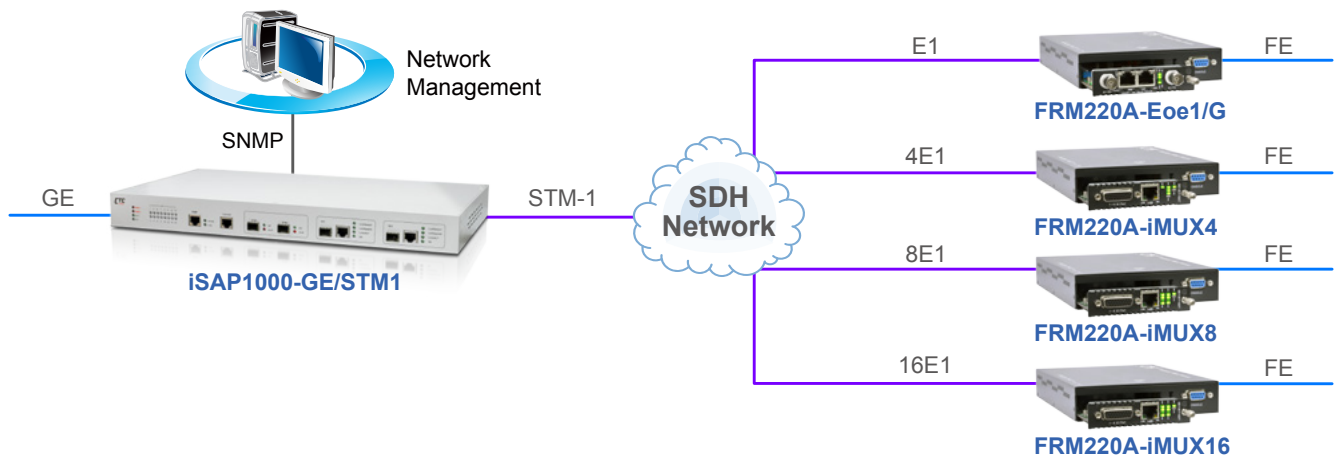

GE + 16E1 over STM-1 Application

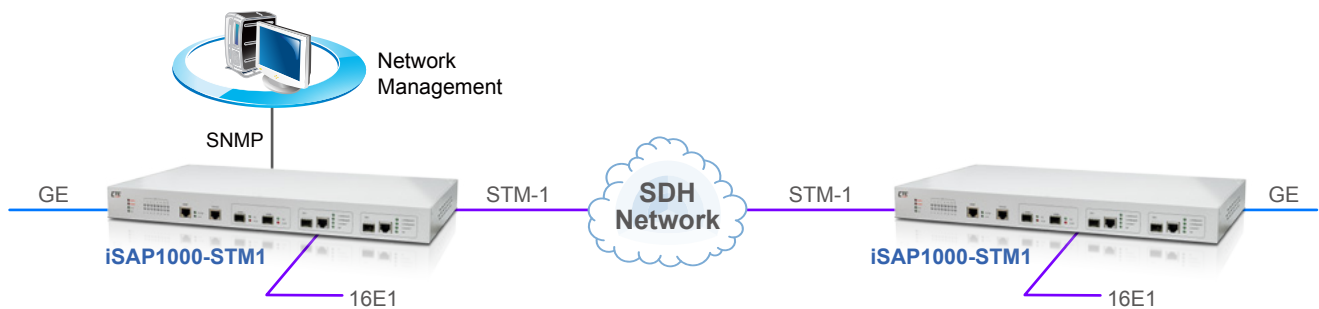

Ordering Information

Model Name	Description
iSAP1000-16E1B-AD	2x GbE Combo over 16E1 BNC, P to P, 1U 19" Rack, AC+DC power
iSAP1000-16E1R-AD	2x GbE Combo over 16E1 RJ45, P to P, 1U 19" Rack, AC+DC power
iSAP1000-GE/16E1B-AD	2x GbE Combo over 16E1 BNC, P to M, 1U 19" Rack, AC+DC power
iSAP1000-GE/16E1R-AD	2x GbE Combo over 16E1 RJ45, P to M, 1U 19" Rack, AC+DC power
iSAP1000-GE/STM1-AD	2x GbE Combo over STM1, P to M, 1U 19" Rack, AC+DC power
iSAP1000-STM1B-AD	2x GbE Combo + 16E1 BNC over STM1, P to P, 1U 19" Rack, AC+DC power
iSAP1000-STM1R-AD	2x GbE Combo + 16E1 RJ45 over STM1, P to P, 1U 19" Rack, AC+DC power

Example: iSAP 1000 – –
Connector Power Type



ERM-MUX-Plus

4x E1 Multiplexer

The ERM-Mux-plus is a 4U 19(23)" 14-slot rack type E1 Time Division Multiplexer for Fractional E1 network access which is designed for non-stop operation. There are 10 slots available for hot-swappable ERM-Mux-plus-I/O cards. Two slots are provided for Mux-E1 cards, which may be configured for redundant 1+1 operation of the E1 lines, safe guarding against expensive network down time. Two slots are also available for CPU cards, with the second CPU card acting as a hot standby in case of primary card failure. Each Mux-E1 card may be linked to another ERM-Mux-plus Rack to provide a point-to-point variety of datacom, Ethernet & voice over E1 network services. The ERM-Mux-plus optionally accommodates up to two separate power supplies, which may derive power from AC (110/220) or DC (-48V) power sources. When two power supplies are installed, the modules provide complete power redundancy and are hot swappable even during the E1 cards' transmission. The ERM-Mux-plus provides all interface connections on the front panel. BNC and RJ-45 are used for E1 Line interface connections, RJ-45 connections are used for all voice (FXO, FXS, E&M), for 10/100 Ethernet Bridge and G.703-64K co-directional / contra-directional / center. Optional cable adapters are used to convert the DB-62F DCE ports of the I/O cards to 6xRS-232, HP68F DCE port of I/O card to 4x V.35, RS-232, RS-530, RS-449, RS-422 and X.21 or 5x X.50 channels.

Feature

- CPU redundancy (1+1)
- E1 redundancy (1+1) and E1 card redundancy
- Power redundancy (1+1) [2AC, 2DC, AC+DC]
- Drop & Insert function
- Console, NMP, SNMP, management
- DCE hot swappable card types
 - 6ch FXS voice
 - 6ch FXO voice
 - 6ch E&M voice
 - 6ch RS232
 - 4ch V.35 (nx64K)
 - 4ch G.703 64K co-directional /contra-directional / center mode
 - 2ch Ethernet bridge

Specifications

Connectors	Console port (RJ45, RS232C)	Environmental	Operating 0°C ~ 60°C
Physical	WAN port RJ45 Jack (2-wire, 4-wire)	Specifications	Storage 0°C ~ 70°C Relative humidity 0% ~ 90% non-condensing Predicted MTBF : 65,000 hrs (25°C)
Specifications	Dimensions: 350 x 438 x 176mm (W x D x H)	Certification	CE
Power Characteristics	Weight: 8kg (chassis+dual power+8 I/O cards) 0.45kg per card		

Application

Connection with PBX (Private Branch Exchange)

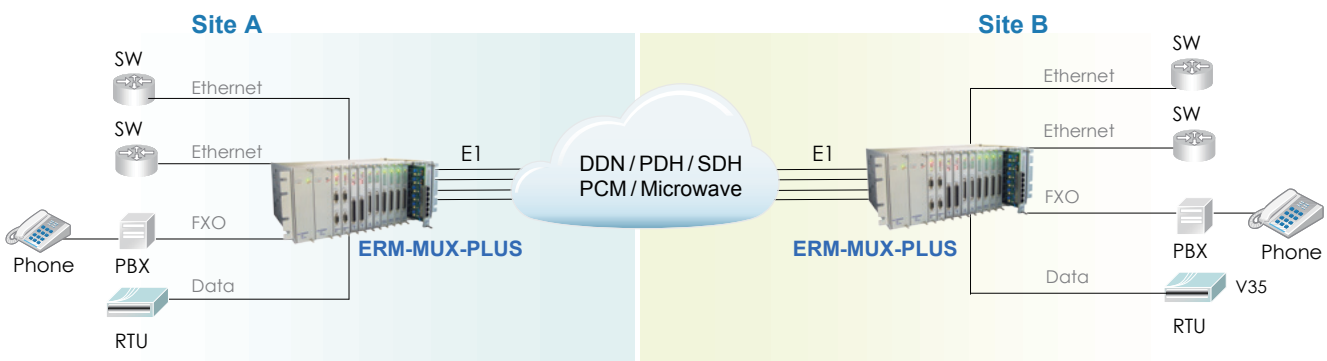

The extension and expansion of DDN (Distributed Data)

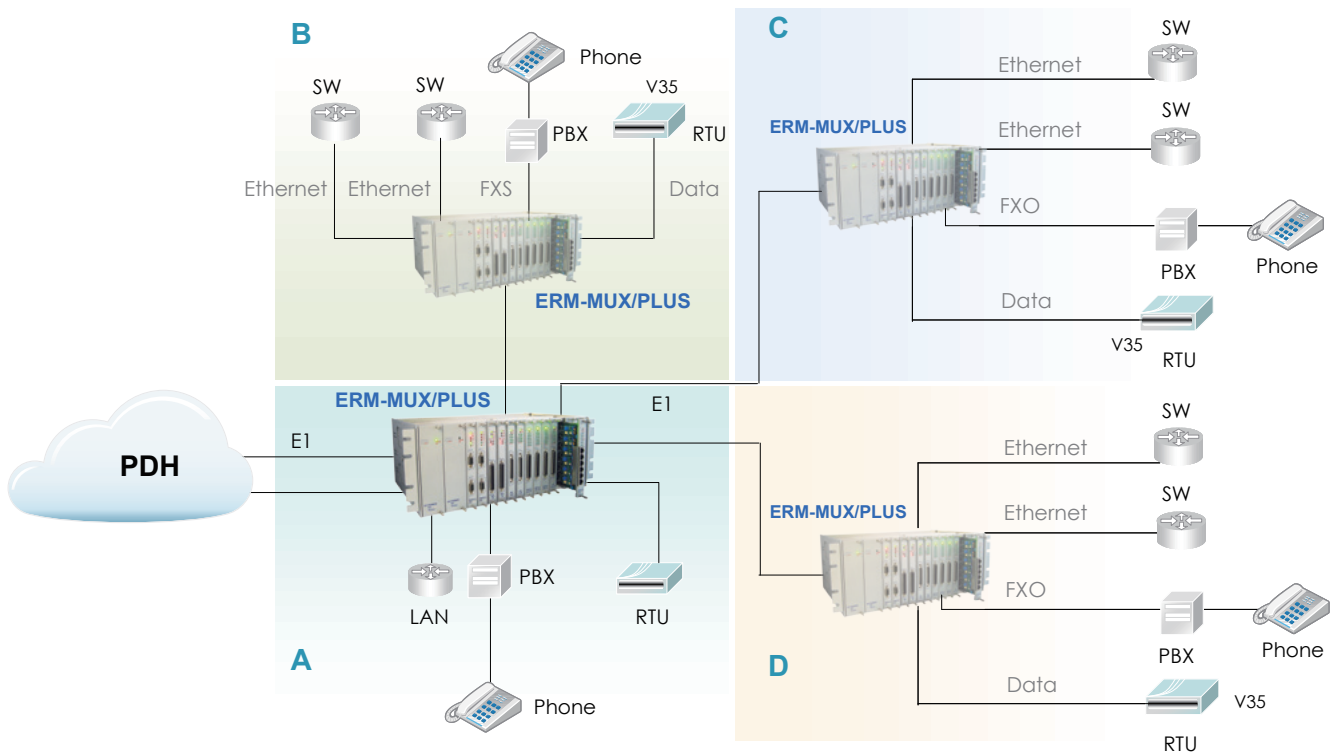

Ordering Information

Model Name	Type	Description
ERM-MUX-PLUS/AA-CH	Chassis	4U 19" 14 slot Chassis for AC+AC power
ERM-MUX-PLUS/DD-CH	Chassis	4U 19" 14 slot Chassis for DC+DC power
ERM-MUX-PLUS/AD-CH	Chassis	4U 19" 14 slot Chassis for AC+DC power
ERM-MUX/AC	Power	AC Power plug-in module (90 to 250 VAC)
ERM-MUX/ACV	Power	AC Power plug-in module (90 to 250 VAC) with Voice support
ERM-MUX/DC	Power	DC Power plug-in module (± 36 to ± 76 VDC)
ERM-MUX/DCV	Power	DC Power plug-in module (± 36 to ± 72 VDC) with Voice support
ERM-MUX-PLUS/GUI	Management	GUI for ERM; support Windows 95, 98, 2000, XP
ERM-MUX-PLUS-2E1R	Card	2-Ch Main-E1 LTU card(V1.2); w/DB37M to 2xRJ45 cable
ERM-MUX-PLUS-2E1B	Card	2-Ch Main-E1 LTU card(V1.2); w/DB37M to 2xBNC cable
ERM-MUX-PLUS-8E1R	Card	8-Ch Main-E1 LTU card(V1.2); w/DB37M to 8xRJ45 cable
ERM-MUX-PLUS-8E1B	Card	8-Ch Main-E1 LTU card(V1.2); w/DB37M to 8xBNC cable
ERM-MUX-PLUS-CPU	Card	CPU card (V4.3) for NMP management
ERM-MUX-PLUS-SNMP	Card	SNMP card (V2.2) for NMP management
ERM-MUX-PLUS-FXO	Card	6-Ch FXO interface card(V2.1)
ERM-MUX-PLUS-FXS	Card	6-Ch FXS interface card(V4.1)
ERM-MUX-PLUS-E&M	Card	6-Ch 2/4 wires E&M voice interface card (V4.1) (Tx/Rx range -20dB ~ +8dB)
ERM-MUX-PLUS-E&M+	Card	6-Ch 2/4 wires E&M voice interface card (V4.1) (Tx range -12dB ~ +16dB, Rx range -20dB ~ +8dB)
ERM-MUX-PLUS-RS-232	Card	6-Ch RS-232 interface card, 64k/128kbps(Sync), 19.2k/38.4kbps(Async)
ERM-MUX-PLUS-ASYNC	Card	6-Ch RS-232 interface card, 9.6k/19.2kbps(Sync), 19.2k/38.4kbps(Async) with multi rate clock function.
ERM-MUX-PLUS-G64K	Card	4-Ch G.703 64k interface card (V4.0)
ERM-MUX-PLUS-HS-SERIAL	Card	4-Ch V.35/X.21/RS-449/RS-530 interface card
ERM-MUX-PLUS-RS485	Card	6-Ch RS-485 / RS-422 Interface card
ERM-MUX-PLUS-ET100	Card	2-Ch Ethernet(10/100Base-TX) interface card (V4.0)

Card Type
ERM - MUX- PLUS -
 Example: ERM - MUX- PLUS - 2E1R



ETU02-MUX

E1 Multiplexer

The ETU02-MUX is a 1U 19(23)" 4 slot rack mountable multiplexing solution for Fractional E1 network services. Up to four DTE devices may be linked to this model at data rates of 64Kbps to 2048Kbps. There is also provision for one optional E1 sub-link which will perform drop & insert with user-defined timeslot connections from a PABX or other E1 equipment to E1 network services. The Fractional E1 2 or 4 port multiplexer supports local control and diagnostics via an LCD display and LED status indicators located on the front panel or via a serial console port. These features enable users to easily configure the unit, execute the in-service diagnostics and monitor the network status. The ETU02-MUX provides for optional SNMP Network Management System, which allow the user to remotely control and manage the system via SNMP protocol. This model fully meets all of the E1 specifications including ITU-T G.703, G.704, G.706, G.732, and G.823.

Feature

- Provides 4 slots, removable interfaces: V35, X21, RS530, RS449, RS232, G.703 Co-directional, NRZ, Ethernet Bridge and Router.
- Optional drop and insert E1 port (Sub E1)
- Built-in BERT with V.54 diagnostic capabilities for performing local and remote loopback
- Setup and Control via front Panel with LCD display or RS-232 terminal
- Multiple clock source selection (Internal or External: E1 recovery, DTE or DCE)
- Optional SNMP management

Specifications

E1 and Sub-E1	Framing: Unframed / Framed CCS(PCM31) Framed: CAS(PCM30) Bit rate: 2.048Mbps±0 ppm Line code: AMI / HDB3 Line impedance: 75 ohm (BNC) / 120 ohm (DB-15, RJ-45)
Transmitter level	Relative receive level: 0 to -43dB Pulse: Nominal 2.37V ±10% for 75ohm Amplitude: Nominal 3.00V ±10% for 120ohm Zero amplitude: ±0.1V Transmit frequency: Internal timing±100 ppm Tracking: Recovery timing±100 ppm External timing: ±100 ppm Jitter performance: According to ITU-T G.823 Return loss: 12dB for 51 ~ 102KHz 18dB for 102 ~ 2048KHz, 14dB for 2048 ~ 3072KHz
User Data Channel	Interface connector: 15-pin D-type F, BNC Data rate: Nx56Kbps or Nx64Kbps Control signals: CTS constantly on DSR constantly on, except during test loops DCD constantly on or follows RTS, except during signal loss Loopback: Line, Payload, local, DTE loopback

User Data Channel	BERT Test Patterns: 511, 2047, 2e15-1, 2e20-1, QRSS, 2e23-1, All 1, All 0, Alt, 0011, 3 in 24, 1 in 16, 1 in 8, 1 in 4 test pattern.
Clock modes	Clock mode 0 (DCE1) Receive and transmit clock (recovered) to the sync DTE Clock mode 0 (DCE2) Receive and transmit clock (internal oscillator) to the sync DTE Clock mode 0 (DCE3) Receive and transmit clock from the sync DCE (from ETC and ERC pin) Clock mode 0 (DCE4) Receive and transmit clock from the sync DCE (all from ETC pin)
Key Pad	4 operation keys
LCD	16 x 2 character backlit LCD
Indications	Signal loss, Sync loss, Alarm (AIS, MRAI, RAI), TD, RD, Error, Test
Standard	ITU-T G.703/G.704/G.706, G.732 & G823
Power Input	AC: 90 ~250V, DC24: -18 ~-36VDC, DC48: -36 ~-72VDC
Power Consumption	10W
Dimensions / Weight	235 x 438 x 45mm (D x W x H) / 2.9kg
Temperature	0~50°C (Operating), -10~70°C (Storage)
Humidity	10~90% non-condensing
Certification	CE, FCC
MTBF	57,000 hrs

Application

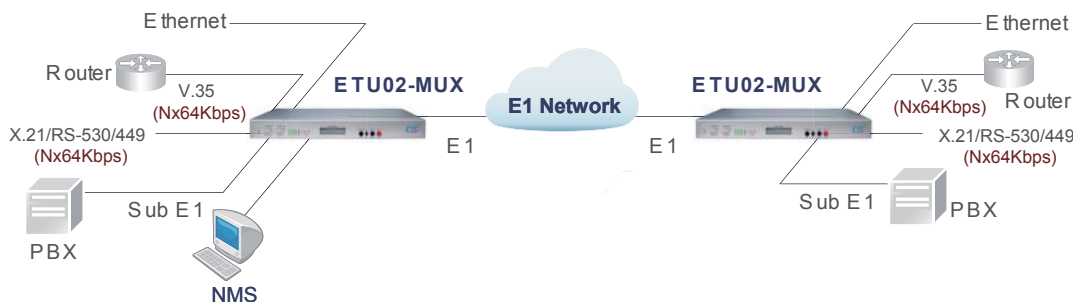

Ordering Information

Model Name	Type	Description
ETU02-Mux4-AC	Power	E1 Mux with 4 data ports, AC power
ETU02-Mux4-DC	Power	E1 Mux with 4 data ports, DC power
ETU02-Mux4-AD	Power	E1 Mux with 4 data ports, AC+DC power
ETU02-Mux2-AC	Power	E1 Mux with 2 data ports, AC power

ETU02-Mux2-DC	Power	E1 Mux with 2 data ports, DC power
ETU02-Mux2-AD	Power	E1 Mux with 2 data ports, AC+DC power

Example: ETU02 – MUX4 – AC



ETU01A

Single Modular Port E1 CSU/DSU w/ LCD and SNMP

The ETU01A single port stand-alone CSU/DSU provides our best digital access solution for E1 and Fractional E1 network services termination. A DTE device may be linked to an ETU01A at data rates of 56Kbps to 2048Kbps. The ETU01A features user replaceable dataport modules for a number of interface standards; including Ethernet bridge, router, V.35, X.21, RS-530, RS-449, RS-232, G.703 Co-directional and RS-232. The ETU01A supports local control and diagnostics via LCD display, keypad and LED status indicators located on the front panel as well as via a menu driven RS-232 console port in conjunction with a standard terminal.

These features enable users to easily configure the unit, execute the in-service diagnostics and monitor the network status. The ETU01A provides optional SNMP (Simple Network Management Protocol), which allows the user to remotely control, diagnose and monitor the system using industry standard SNMP protocol, our proprietary MIB and any network management software.

Feature

- Supports Fractional E1 and Unframed E1 service with EOC control
- Removable interfaces, support V.35, X.21, RS-530, RS-449, RS-232, G.703 Co-directional, NRZ, Ethernet Bridge and Router
- I/O connectors on rear panel
- Multiple clock source selection (Internal or External: E1 recovery, DTE or DCE)
- Supports Console, Telnet and SNMP management
- Menu keys and LCD display
- SNMP V1, V2C, V3 supported
- Supported by Smart View EMS
- Built-in BERT with V.54 diagnostic capabilities for performing local and remote loopback

Specifications

G.703 E1	Framing	Framed CCS (PCM31) CAS (PCM30) / Unframed CRC4 on/off
	Line Code	AMI/ HDB3
	LCD display	16 x 2 character LCD with backlight
	Bit rate	N x 56K or N x 64Kbps, where N=1~31 in CCS or 1~30 in CAS
	Relative receive level	0 to -43dB
	Transmit level:	
	Pulse	Nominal 2.37V ±10% for 75ohm
	Amplitude	Nominal 3.00V ±10% for 120ohm Zero amplitude ±0.1V
	Jitter performance	According to ITU-T G.823
	Connectors	BNC(unbalanced), RJ-48(balanced)
	Clock modes:	
	Clock mode 0	Receive & transmit clock (DCE1) (recovered) to the sync DTE
	Clock mode 1	Receive & transmit clock (DCE2) (internal oscillator) to the sync DTE

G.703 E1	Clock mode 2	Receive clock to the sync and transmit (DTE1) clock from the sync device
	Clock mode 3	Receive and transmit clock from the (DTE2) sync DCE (from ETC and ERC pin)
	Clock mode 4	Receive and transmit clock from the (DTE3) sync DCE (all from ETC pin)
Diagnostics	local loopback, Digital remote loopback, Test pattern	
Indicators	LEDs (Power, TD, RD, Signal loss, Sync loss, Error and test)	
Standards	ITU-T G.703/G.704/G.706 & G.732	
Power Input	AC: 90-250VAC, DC: 18-72 VCD	
Power Consumption	10W	
Dimensions	250 x 195 x 45 mm (D x W x H)	
Weight	1.5kg	
Temperature	0 ~ 50°C (Operating), -1 ~ 70°C (Storage)	
Humidity	10 ~ 90% non-condensing	
Certification	CE, FCC	
MTBF	65,000 hrs	

Application

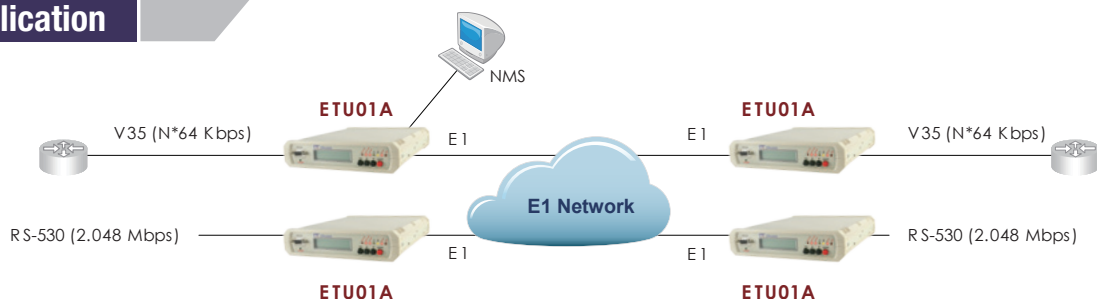

Ordering Information

Model Name	Type	Description
ETU01A/AC	Power	1U, 19/2", Data port to framed E1 with 100 ~240VAC
ETU01A/DC	Power	1U, 19/2", Data port to framed E1 with -48VDC
Interface Module	Description	
ETU/TTU-V35	V.35 interface module	
ETU/TTU-X21	X.21 interface module	
ETU/TTU-530	RS-530 interface module	

ETU/TTU-449	RS-449 interface module
ETU/TTU-232	RS-232 ASYN/SYNC interface module
ETU/TTU-G64	G.703 64Kbps co-directional interface module
ETU/TTU-NRZ	NRZ interface module (4 * BNC)
ETU/TTU-ET100	10/100 Base-Tx Ethernet E1 Bridge interface module
ETU/TTU-ET100R	10/100 Base-Tx Ethernet Routing interface module

Power Type
ETU01A/□□
 Example: ETU01A/AC



ETU011

Single Modular Port E1 CSU/DSU

The ETU011 stand-alone DSU/CSU is a digital access unit for Unframed E1, Fractional E1, or Fractional cascaded E1 service. The ETU011 data channel supports user-selectable transmission rates via randomly selected E1 timeslots, which provides integral multiples of 64kbps, up to a maximum 2.048Mbps (unframed), for a line attenuation of up to 43 dB on twisted pair or coax cable. This provides an approximate operating range up to 2km (using 22AWG). The ETU011 packs the data channels into the E1 link in user-selected time slots. The unused time slots can insert IDLE code (in frame mode). The ETU011 front panel sports status LEDs for monitoring both the CSU and DSU conditions and push button switches for initiating local and remote loopback with integral BERT.

Feature

- Supports Fractional E1 and Unframed E1 service
- Removable interfaces, support V.35, X21, RS-530, RS-449, RS-232, G.703 Co-directional, NRZ, Ethernet Bridge and Router
- I/O connectors on rear panel
- Multiple clock source selection
- (Internal or External: E1 recovery, DTE or DCE)
- Built-in BERT with V.54 diagnostic capabilities for performing local and remote loopback

Specifications

G.703 E1	Framing	Framed CCS (PCM31) CAS (PCM30)/ Unframed CRC4 on/off
	Line Code	AMI/ HDB3
	Bit rate	N x 56K or N x 64Kbps, where N=1~31 in CCS or N equal 1~30 in CAS
	Relative receive level	-43dB
	Transmit level:	
	Pulse Amplitude	Nominal 2.37V ±10% for 75 ohm Zero amplitude ±0.1V
	Jitter performance	According to ITU-T G.823
	Connectors	BNC(unbalanced), RJ-48(balanced)
	Clock modes:	
	Clock mode 0	Receive & transmit clock (DCE1) (recovered) to the sync DTE
	Clock mode 1	Receive & transmit clock (DCE2) (internal oscillator) to the sync DTE

G.703 E1	Clock mode 2	Receive clock to the sync. and transmit (DTE1) clock from the sync device
	Clock mode 3	Receive and transmit clock from the (DTE2) sync DCE (from ETC and ERC pin)
	Clock mode 4	Receive and transmit clock from the (DTE3) sync DCE (all from ETC pin)
	Indicators	LEDs (Power, TD, RD, RTS, DCD, Signal loss, Sync loss, Alarm)
Standards	ITU-T G.703/G.704/G.706 & G.732	
Power Input	AC: 90-250VAC, DC: -18 ~ -75VDC	
Power Consumption	10W	
Dimensions	250 x 195 x 45 mm (D x W x H)	
Weight	0.51kg	
Temperature	0°C ~ 50°C (Operating), -10°C ~ 70°C (Storage)	
Humidity	10 ~ 90% non-condensing	
Certification	CE, FCC	
MTBF	57,000 hrs	

Application

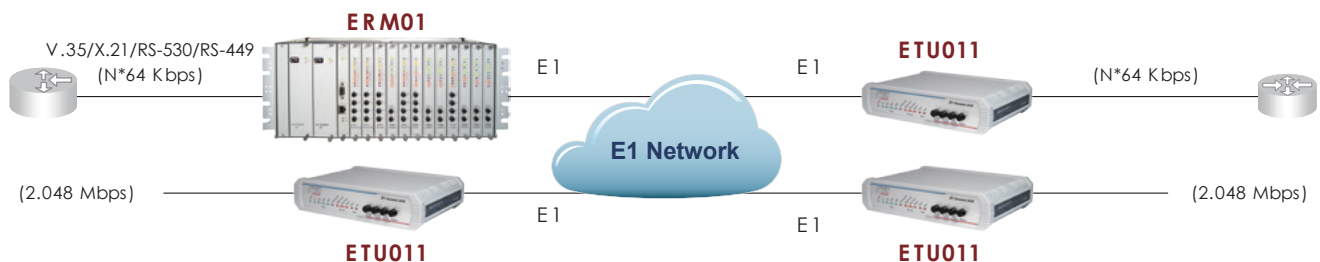

Ordering Information

Model Name	Description
ETU/TTU-V35	V35 interface module
ETU/TTU-X21	X21 interface module
ETU/TTU-530	RS-530 interface module
ETU/TTU-449	RS-449 interface module
ETU/TTU-232	RS-232 ASYN/SYNC interface module
ETU/TTU-G64	G.703 64Kbps co-directional interface module
ETU/TTU-NRZ	NRZ interface module (4 * BNC)
ETU/TTU-ET100	10/100 Base-TX Ethernet E1 Bridge interface module
ETU/TTU-ET100R	10/100 Base-TX Ethernet Routing interface module

Model Name	Description
Stand Alone Types	
ETU011-AC	Single port to fractional E1 unit with built-in AC 90 ~ 250V
ETU011-DC	Single port to fractional E1 unit with built-in DC -18 ~ -72V
Rack Mount Types	
ETU011-R-AC	Single port to fractional E1 Rack Mount unit with built-in AC 90 ~ 250V
ETU011-R-DC	Single port to fractional E1 Rack Mount unit with built-in DC -18 ~ -72V

Power Type
ETU011 –
 Example: ETU011 – AC

Interface Module for ETU01A & ETU011

ETU/TTU-V35

V.35 Interface

Features :

- Compliant with ITU-T V.35 standards
- Winchester type 34-pin MB34 M-Block female connector
- Synchronous data rate at Nx64 (where N=1 to 32)
- Data Communications Equipment interface electrically compatible to ITU-T V.11 (RS-422)

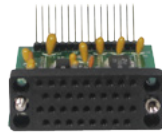

ETU/TTU-232

RS-232 Interface

Features :

- Compliant with EIA RS-232-C (Unbalanced)
- Compatible to ITU-T V.24 25-pin D Sub female connector
- Synchronous data rate at 64 or 128Kb/s Asynchronous (transparent) at up to 19.2K or 38.4K Data Communications Equipment interface

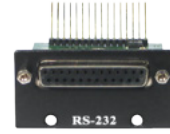

ETU/TTU-X21

X.21 Interface

Features :

- Compliant with ITU-T X.21 standard (Balanced)
- 15-pin D Sub female connector
- Synchronous data rate at Nx64 (where N=1 to 32)
- Data Communications Equipment interface electrically compatible to V.11



ETU/TTU-530

RS-530 Interface

Features :

- Compliant with Category 1 EIA-530 (Balanced) 25-pin D Sub female connector
- Synchronous data rate at Nx64 (where N=1 to 32)
- Data Communications Equipment interface electrically compatible to RS-422



ETU/TTU-NRZ

Non-Return to Zero Interface

Features :

- 4 BNC connectors: TxD, TxC, RxD and RxC (Data&Clock)
- NRZ line coding Logic "1" 0V +/- 0.3V Logic "0" -1.5V +/- 0.3V
- Synchronous data rate Nx64 (where N=1 to 32)



ETU/TTU-449

RS-449(V.36) Interface

Features :

- Compliant with EIA/TIA-530-A (Balanced)
- 37-pin D Sub female connector
- Synchronous data rate at Nx64 (where N=1 to 32)
- Data Communications Equipment interface electrically compatible to RS-422



ETU/TTU-G64

G.703 64K Co-directional Interface

Features :

- Pulse shape compliant with ITU-T G.703
- Clock frequency: 64KHz
- Pulse Amplitude: 1.0V
- Zero Amplitude: 0V
- Impedance: 120 Ohms
- 15-Pin D Sub connector
- Range: up to 800m with 24AWG



ETU/TTU-ET100R

10/100 Base-TX Ethernet Router

Features :

- Ethernet port IP Address/subnet mask
- Dynamic Routing RIP I & II, Send or Receive on Ethernet or WAN
- PPP, HDLC and Cisco® HDLC WAN protocol encapsulation

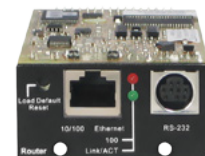

ETU/TTU-ET100

10/100 Base-TX Ethernet Bridge

Features :

- High performance bridge for 10Base-T or 100Base-TX Ethernet extension
- Transparent half / Full duplex support on WAN / LAN interface
- Provides Ethernet over E1 economically



Ordering Information

Model Name	Description
ETU/TTU-V35	V.35 interface module
ETU/TTU-X21	X.21 interface module
ETU/TTU-530	RS-530 interface module
ETU/TTU-449	RS-449 interface module

Model Name	Description
ETU/TTU-232	RS-232 ASYN/SYNC interface module
ETU/TTU-G64	G.703 64Kbps co-directional interface module
ETU/TTU-NRZ	NRZ interface module (4 * BNC)
ETU/TTU-ET100	10/100Base-TX Ethernet E1 Bridge interface module
ETU/TTU-ET100R	10/100Base-TX Ethernet Routing interface module

Interface
ETU/TTU - □□□□
 Example: ETU/TTU - V35



ETU01-Plus

Single V.35 Port E1 CSU/DSU

The ETU01-Plus stand-alone CSU/DSU is a digital access unit for Unframed E1 or Fractional E1 service. The ETU01-Plus data channel supports user-selectable transmission rates via randomly selected E1 timeslots, which provides integral multiples of 64kbps, up to a maximum 2.048Mbps (unframed), for a line attenuation of up to 43 dB on twisted pair or coax cable. This provides an approximate operating range up to 2km (using 22AWG). The ETU01-Plus packs the data channels into the E1 link in user-selected time slots. The ETU01-Plus front panel sports status LEDs for monitoring the CSU and DSU conditions and pushbutton switches for initiating local and remote loopback with integral BERT. The ETU01-Plus features a fixed on-board V.35 interface.

Feature

- Supports Fractional E1 and Unframed E1 service with EOC control
- Model with fixed V.35 interface for price critical applications
- Multiple clock source selection (Internal or External: E1 recovery, DTE or DCE)
- Built-in BERT with V.54 diagnostic capabilities for performing local and remote loopback
- Fixed V.35 port with MB34F connector
- I/O connectors all located on rear panel

Specifications

G.703 E1	Framing	Framed CCS (PCM31) CAS (PCM30)/ Unframed CRC4 on/off
	Line Code	AMI/ HDB3
	Data rate	N x 56K or N x 64Kbps, where N=1~31 in CCS or N equal 1~30 in CAS
	Relative receive level	-43dB
	Transmit level:	
	Pulse Amplitude	Nominal 2.37V ±10% for 75 ohm Nominal 3.00V ±10% for 120 ohm Zero amplitude ±0.1V
	Jitter performance	According to ITU-T G.823
	Connectors	BNC(unbalanced), RJ-48(balanced)
	Clock modes:	
	Clock mode 0	Receive & transmit clock (DCE1) (recovered) to the sync DTE
	Clock mode 1	Receive & transmit clock (DCE2) (internal oscillator) to the sync DTE

G.703 E1	Clock mode 2	Receive clock to the sync. and transmit (DTE1) clock from the sync device
	Clock mode 3	Receive and transmit clock from the (DTE2) sync DCE (from ETC and ERC pin)
	Clock mode 4	Receive and transmit clock from the (DTE3) sync DCE (all from ETC pin)
Indications	LEDs (Power, TD, RD, RTS, DCD, Signal loss, Sync loss, Alarm)	
Standards	ITU-T G.703/G.704/G.706 & G.732	
Power Input	AC: 90-250VAC , DC: -18 ~ -75 VDC	
Power Consumption	10W	
Dimensions	195 x 160 x 45 mm (D x W x H)	
Weight	0.51kg	
Temperature	0°C ~ 50°C (Operating), -10°C ~ 70°C (Storage)	
Humidity	10 ~ 90% non-condensing	
Certification	CE, FCC	
MTBF	55,000 hrs	

Application

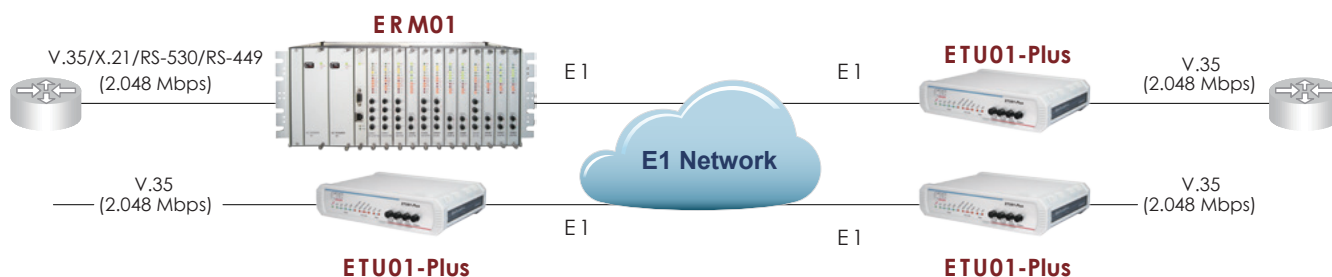

Ordering Information

Model Name	Description
Stand Alone Types	
ETU01/Plus-AC	V.35/MB34F port, fractional E1 unit with built-in AC 90 ~ 250 VAC
ETU01/Plus-DC	V.35/MB34F port, fractional E1 unit with built-in DC -18 ~ -75 V
Rack Mount Types	
ETU01/Plus-R-AC	V.35/MB34F port, fractional E1 Rack Mount type unit w/ built-in AC 90 ~ 250 VAC
ETU01/Plus-R-DC	V.35/MB34F port, fractional E1 Rack Mount type unit w/ built-in DC -18 ~ -75 V

Power Type
ETU01/Plus –
 Example: ETU01/Plus – AC



Eoe1A

Ethernet over E1 with SNMP Management

The Eoe1A is a Channel Service Unit for unframed ITU-T G.703 E1 that features a built-in Ethernet bridge. The CSU has a built-in Network Terminating Unit (NTU) and may connect to either 75 Ohm unbalanced, BNC connectors or to 120 Ohm balanced, unframed E1 via twisted pairs and a shielded RJ-45 connector. The Eoe1A Ethernet Bridge uses HDLC encapsulation to transport Ethernet packets across the WAN and supports 10/100 auto-negotiation or manual settings for 10M, 100M, Full or Half Duplex Ethernet. The Ethernet port also supports a standard auto-MDIX feature that will completely eliminate Ethernet cross-over cables or the guessing that is sometimes involved in choosing a cable when connecting to a HUB or a PC. The Eoe1A is very easy to configure by a menu driven serial console interface. SNMP and proprietary MIB add the ability to manage the Eoe1A centrally through third party network management software or via CTC Union's EMS management system.

Feature

- Supports 10/100Base-TX Ethernet over Unframed E1
- Automatic address learning, aging and deletion after 5 minutes
- Auto padding of undersized packets to meet the minimum Ethernet packet size requirement
- Buffering modes can be selected according to the setting of WAN and LAN line speeds
- Forwarding and filtering rate at WAN speed with throughput latency of 1 frame
- Auto MDI / MDIX
- Real-time filtering with 256 MAC address table
- Supports Console, SNMP and Web management
- Adjustable pay load rates of: 10K, 32K, 64K, 128K, 256K, 512K, 1024K & 2048K

Specifications

G.703 E1 Specifications

Framing	Unframed
Line code	AMI/ HDB3
Bit rate	2.048Mbps (clear channel)
Relative receive level	0 to -43dB
Transmit level	Pulse Nominal 2.37V ±10% for 75ohm Amplitude Nominal 3.00V ±10% for 120ohm Zero amplitude ±0.1V
Jitter performance	According to ITU-T G.823
Connector	BNC(unbalanced), RJ-48(balanced)
Clock modes	Clock mode 0: Receive & transmit clock (DCE1)(recovered) to the sync DTE Clock mode 1: Receive & transmit clock (DCE2)(internal oscillator) to the sync DTE
Diagnostics	
Test Switches	Digital local loopback, Analog local loopback, Digital local and remote loopback, 2047 Test pattern
Ethernet Specifications	
Connector	RJ-45

Data Rate	10/100Mbps; Half Duplex / 20/ 200Mbps; Full duplex
Filtering & Forwarding	90,000 packets/sec
Delay	1 frame
Frame Buffer	340 frames
MAC Table	256 MAC address
Protocols	Synchronous HDLC
Indications	LEDs (Power, Signal Loss, Alarm, Link, TD, RD, 100, Full, Error, Error, Test)
Standards	ITU-T G.703, G.706 and G.732, IEEE 802.3/802.3u
Management	Console, Web, SNMP
Power Input	AC: 90-250VAC ; DC: 18-72 VCD
Power Consumption	20W
Dimensions	250 x 195 x 45mm (D x W x H)
Weight	1.5kg
Temperature	0°C ~ 50°C (Operating), -10°C ~ 70°C (Storage)
Humidity	10 ~ 90% non-condensing
Certification	CE, FCC
MTBF	57,000 hrs

Application

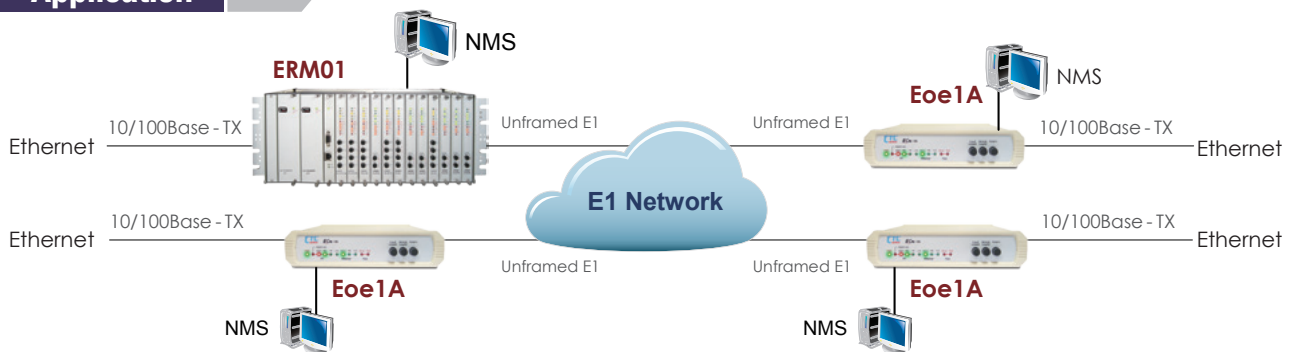

Ordering Information

Model Name	Description
Eoe1A/AC	1U half 19" Ethernet over unframed E1 SNMP with AC power (100 ~ 240V)
Eoe1A/DC	1U half 19" Ethernet over unframed E1 SNMP with DC power (18 ~ 75V)
Eoe1A/AD	1U half 19" Ethernet over unframed E1 SNMP with AC (100~240V) and DC (18 ~ 75V)

Power Type
Eoe1A -
 Example: **Eoe1A** - AD



ET100A (v2)

Ethernet to WAN (V.35/RS530/449/232/X.21) Bridge

The ET100A Network Bridge is a high performance remote, self-learning, Ethernet bridge. Its compact size and low cost makes it ideal for cost-sensitive bridging applications, or as a LAN extender or segmenter over bit stream type infrastructures. The built-in n x 64 (56)Kbps timing clock generator makes it easy to connect to other n x 64 (56)Kbps related data equipment. Several options of data interfaces, including V.35, RS-530, RS-449, RS-232, and X.21 make this unit's connection between 10Base-T or 100Base-TX LAN and various data port interfaces convenient.

Feature

- Protocol : Synchronous HDLC (ISO 13239), PPP, CISCO® HDLC
- 10Base-T or 100Base-TX Ethernet bridge
- Auto MDI/MDIX
- Supports IEEE 802.3x flow control
- Selectable data port : V.35, RS-530, RS-449, RS-232, X.21
- Transparent half / Full duplex support on WAN, LAN interface
- Nx64, Nx56 timing clock generator for Sync WAN link
- LEDs indication for LAN, WAN status

Specifications

WAN	Interface:	Selectable RS-232(Sync), V.35, RS-530, RS-449, RS-232, X.21with Adapter Cable	LAN	Compliant with IEEE 802.3, 802.3u, 802.3x		
	Protocol:	Synchronous PPP, HDLC (ISO 13239), CISCO® HDLC		Connector: RJ-45		
	Connector:	DB25M		Speeds: 10/100Base-TX, Full/Half duplex		
	Type:	DTE		Frames: Support 64 ~ 2044 byte packet lengths		
	Configuration:	All Configuration by Dip switch (Protocol, interface, Clock mode, data rate)		Bridge Specifications	MAC Address learning, aging and deletion after 5 minutes	
	Data rate:	Nx56Kbps, Nx64Kbps RS-232 up to 128Kbps V.35, X21, RS-530, RS-449 up to 10Mbps		256 addresses MAC table, 1763 packet buffer	Power	12VDC
	Clock source:	Tx/Rx internal or external		Power Consumption	< 5 W	
	Handshake (DCD)	Follow CTS/RTS or Always On		Dimensions	135 x 79 x 25mm (D x W x H)	
	Indications	LEDs (PWR, WAN Rx/Tx, LAN Tx/Rx/Link/Err/Speed)		Weight	180g	
				Temperature	0°C ~ 50°C (Operating), -10°C ~ 70°C (Storage)	
		Humidity	10 ~ 90% non-condensing			
		Certification	CE, FCC			

Application

Ethernet over TDM, Point to Point

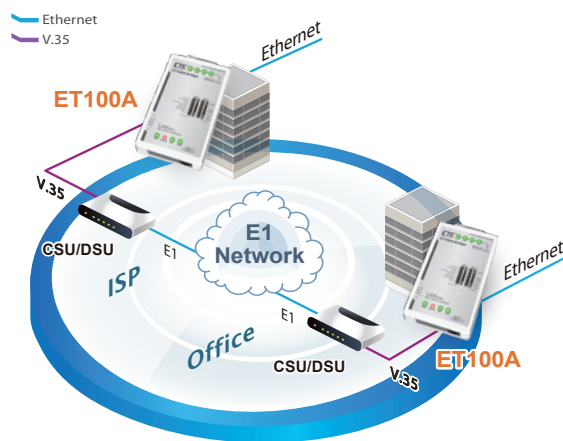

HDLC Bridge Application

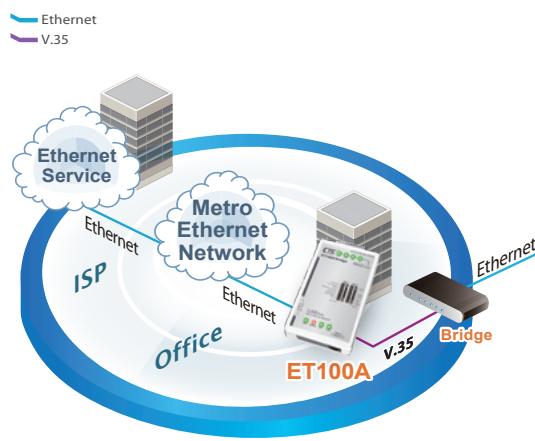

Ordering Information

Model Name	Description
ET100A/V35M	Ethernet to V35 WAN Bridge with V.35 cable: DB25F to MB34M, 1 meter
ET100A/X21M	Ethernet to X21 WAN Bridge with X21 cable: DB25F to DB15M, 1 meter
ET100A/RS530M	Ethernet to RS530 WAN Bridge with RS530 cable: DB25F to DB25M, 1 meter
ET100A/RS449M	Ethernet to RS449 WAN Bridge with RS449 cable: DB25F to DB37M, 1 meter
ET100A/RS232M	Ethernet to RS232 WAN Bridge with RS232 cable: DB25F to DB25M, 1 meter



IPM-1SE/V35

E1/V.35 over Ethernet Access Unit

IPM-1SE/V35 is designed as a multi-service access platform for PDH and V.35 over Ethernet applications. Structured/unstructured E1 and V.35 data can be mapped/de-mapped into/from Ethernet packets. An adaptive clock recovery method for Ingress PDH (PSN -> TDM) clock generation is implemented to support E1 (ITU-T G.824) Jitter performance.

Cost-effective LAN deployment (PDH and V.35 over ethernet)

IPM-1SE/V35 provides cost-effective applications of traditional circuit-switched system over Ethernet. With IPM-1SE/V35, it is easy to interconnect with existing phone systems and V.35 over Ethernet that are used to carry data, voice and video.

Transparent transmission

IPM-1SE/V35 can transparently transport proprietary signaling that are required to support PBX features, including call conference, call forwarding and SS7. Customer can easily apply and enjoy better integration of TDM, V.35 and Ethernet devices with lower network expense.

Bypass international toll

With a pair of IPM-1SE/V35 and guaranteed internet bandwidth, it is sure to save cost dramatically, and to ensure the QoS of voice based on interconnections of TDM telecommunications equipment.

Feature

- Supports IEFTRFC4533 Structure-Agnostic TDM over Packet (SAToP), Metro Ethernet Forum MEF8.
- One E1 NRZ Serial Interface with LOS/AIS detection.
- One V.35 (Nx64K) interface.
- Use Raw Encapsulation method for PDH payload over Ethernet packet.
- Supports Circuit Emulation Service over Ethernet (CESoE) transport over Ethernet networks.
- Comply with IEFTRFC4533 standard for CESoPSN and SAToP; Metro Ethernet Forum MEF8 IA.
- Supports both Point-to-Point and Point-to-Multipoint operation.
- Supports Adaptive Clock recovery block for Ingress PDH (PSN -> TDM) clock generation. Recovered clock jitter is compliant to ITU-T G.824 (E1 Jitter Control).
- Configurable jitter buffer depth to compensate up to 40ms of Packet Delay Variation.
- Lost packets processing/compensation via PW (Pseudo Wire) control field Sequence Number.
- Provides Subscriber side data traffic bandwidth control to guarantee enough TDM payload bandwidth.
- PDH LOS detection triggered PW L field or payload AIS generation at Egress direction (TDM -> PSN).
- Configurable IEEE 802.3 DA/SA assignment.

Specifications

Line interface (CPE side)	Port: One E1 (ITU-T G.703) and one V.35. Interface: RJ-48c (120 Ohm), BNC (75 Ohm) and M/34 female (V.35, DCE). E1 Line Coding: HDB3
Ethernet interface (CPE/CO side)	Port: two 100 Base-T Ethernet. One is for downlink and the other is for uplink Interface: RJ-45
Dimensions	44 x 370 x 215 mm (D x W x H)

Power	AC: 110 ~ 240V @ 47 ~ 65Hz DC: -72V ~ -36V
Environment	Ambient temperature: 0°C ~ 50°C (0°C ~ 65°C, optional) Storage temperature: 0°C~ 85°C Relative humidity: 5 ~ 95% non condensing
Management	Console port (CLI) or SNMP-based / Web GUI management

Application

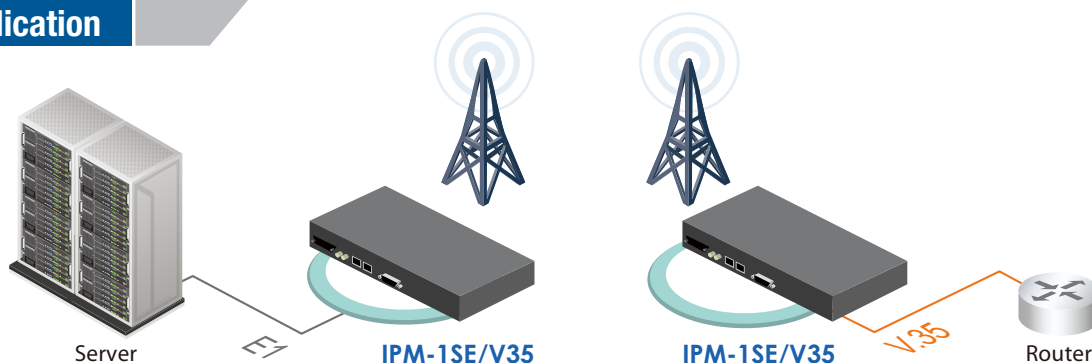

Ordering Information

Model Name	Description
IPM-1SE/V35-AD	E1/V.35 over Ethernet access unit with AC+DC Power



IPM-E1/IPM-4E1

E1/4x E1 over Ethernet

IPM-E1/4E1 is designed as a multi-service access platform for PDH over IP applications. E1 frames can be mapped/de-mapped into/from IP packets. An adaptive clock recovery method for Ingress PDH (PSN->TDM) clock generation is implemented to support E1 (ITU-T G.823) Jitter performance.

IPM-E1/4E1 provides cost-effective applications of traditional circuit-switched system over IP. It is easy to interconnect existing phone systems over IP that are used to carry data, voice and video. With high precision clock recovery technology, IPM-E1/4E1 is capable of supporting 2G/3G/4G backhaul and provides smooth services. IPM-E1/4E1 can transparently transport proprietary signaling that are required to support PBX features, including call conference, call forwarding and SS7. Customer can easily apply and enjoy better integration of TDM and IP devices with lower network expense. With a pair of IPM-E1/4E1 and guaranteed internet bandwidth, it is sure to save cost dramatically, and to ensure the QoS of voice based on interconnections of TDM equipment.

Feature

- Supports Web Management
- Supports IETF RFC4553 Structure-Agnostic TDM over Packet (SAToP), Metro Ethernet Forum MEF8
- Use Raw Encapsulation method for PDH payload over Ethernet packet
- Supports Circuit Emulation Service over Ethernet networks
- Comply with IETF draft standard for CESoPSN and SAToP; Metro Ethernet Forum MEF8 IA
- Supports both Point-to-Point and Point-to-Multipoint operation
- Supports Adaptive Clock recovery block for Ingress PDH (PSN -> TDM) clock generation. Recovered clock jitter is compliant to ITU-T G.823 (E1 Jitter Control)
- Configurable jitter buffer depth to compensate PDV (Packet Delay Variation) with the flexible setting of 11ms, 23ms, 40ms, 75 ms
- Lost packets processing / compensation via PW (Pseudo Wire) control field Sequence Number
- Provide Subscriber side Data traffic bandwidth control to guarantee enough TDM payload bandwidth
- PDH LOS detection triggered PW L field or payload AIS generation at Egress direction (TDM->PSN)
- Configurable IEEE 802.3 DA/SA assignment
- LED alarm display for E1 Power failure status
- E1 NRZ Serial Interface with LOS/AIS detection

Specifications

E1 Interface	Standards	ITU-T G.703, G.704, G.706, G.732
	Ports	1 or 4-Port
	Data Rate	2.048Mbps ±50ppm
	Connector	RJ-48c for 120 ohm
	Line Coding	HDB3
Ethernet Interface	WAN Port	100 Base-TX Ethernet
	Interface	RJ-45
	LAN port	100 Bases-TX Ethernet
	Interface	RJ-45

Dimensions	125 x 320 x 44 mm (D x W x H)
Power	AC: 85 ~ 264V @ 47 ~ 63Hz
	DC: -72V ~ -36V
Environment	Ambient temperature: 0° ~ 50°
	Storage temperature: 0°~ 85°
	Humidity: 5 ~ 95% non-condensing
Management	Console or Telnet / Web / SNMP management (via Ethernet)

Application

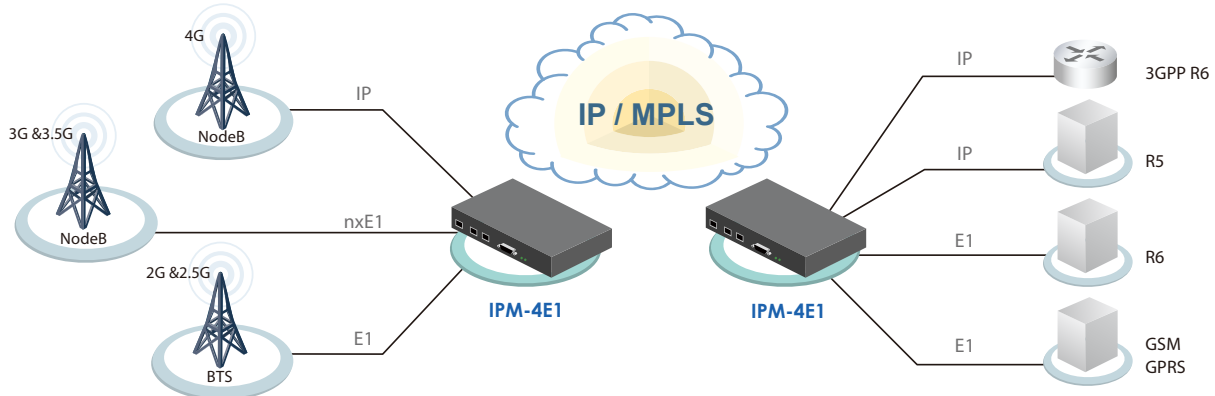

Ordering Information

Model Name	Description
IPM-E1-AD	E1 over Ethernet with built-in AC+DC Power
IPM-4E1-AD	4E1 over Ethernet with built-in AC+DC Power

Port Number Power Type
IPM - □□□□ - □□
 Example: IPM - 4E1 - AD



IPM-8E1/IPM-16E1

8/16x E1 over Ethernet

IPM-8E1 & IPM-16E1 is designed as a multi-service access platform for PDH over IP applications. E1 frames can be mapped/de-mapped into/from IP packets. An adaptive clock recovery method for Ingress PDH (PSN->TDM) clock generation is implemented to support E1 (ITU-T G.823) Jitter performance.

IPM-8E1 & IPM-16E1 provides cost-effective applications of traditional circuit-switched system over IP. It is easy to interconnect existing phone systems over IP that are used to carry data, voice and video. With high precision clock recovery technology, IPM-8E1 & IPM-16E1 is capable of supporting 2G/3G/4G backhaul and provides smooth services. IPM-8E1 & IPM-16E1 can transparently transport proprietary signaling that are required to support PBX features, including call conference, call forwarding and SS7. Customer can easily apply and enjoy better integration of TDM and IP devices with lower network expense. With a pair of IPM-8E1 & IPM-16E1 and guaranteed internet bandwidth, it is sure to save cost dramatically, and to ensure the QoS of voice based on interconnections of TDM equipment.

Feature

- Supports Web Management
- Supports IETF RFC4553 Structure-Agnostic TDM over Packet (SAToP), Metro Ethernet Forum MEF8
- 8 /16 x E1 NRZ Serial Interface with LOS/AIS detection
- Use Raw Encapsulation method for PDH payload over IP packet
- Supports Circuit Emulation Service over IPE
- Comply with IETF draft standard for CESoPSN and SAToP; Metro Ethernet Forum MEF8 IA
- Supports both Point-to-Point and Point-to-Multipoint operation
- Configurable IEEE 802.3 DA/SA assignment
- Supports 8/16 independent Adaptive Clock recovery block for Ingress PDH (PSN->TDM) clock generation. Recovered clock jitter is compliant with ITU-T G.823 (E1 Jitter Control)
- Independent configurable jitter buffer depth to compensate up to 250ms of Packet Delay Variation
- Lost packets processing / compensation via PW (Pseudo Wire) control field Sequence Number
- PDH LOS detection triggered PW L field or payload AIS generation at Egress direction (TDM->PSN)
- LED alarm display for E1 Power failure status

Specifications

E1 Interface	Standards	ITU-T G.703, G.704, G.706, G.732
	Ports	8 or 16-Port
	Data Rate	2.048Mbps ±50ppm
	Connector	RJ-45 for 120 ohm
	Line Coding	HDB3
Ethernet Interface	WAN Port	1 x 100Base-TX Ethernet
	Interface	RJ-45
Dimensions	268 x 290 x 44 mm (D x W x H)	

Power	AC:	85 ~ 264V @ 47 ~ 63Hz
	DC:	-72V ~ -36V
Environment	Ambient temperature:	0° ~ 50°
	Storage temperature:	0° ~ 85°
	Humidity:	5 ~ 95% non-condensing
Management	Console port or Telnet/ Web / SNMP-based management via NMS port	

Application

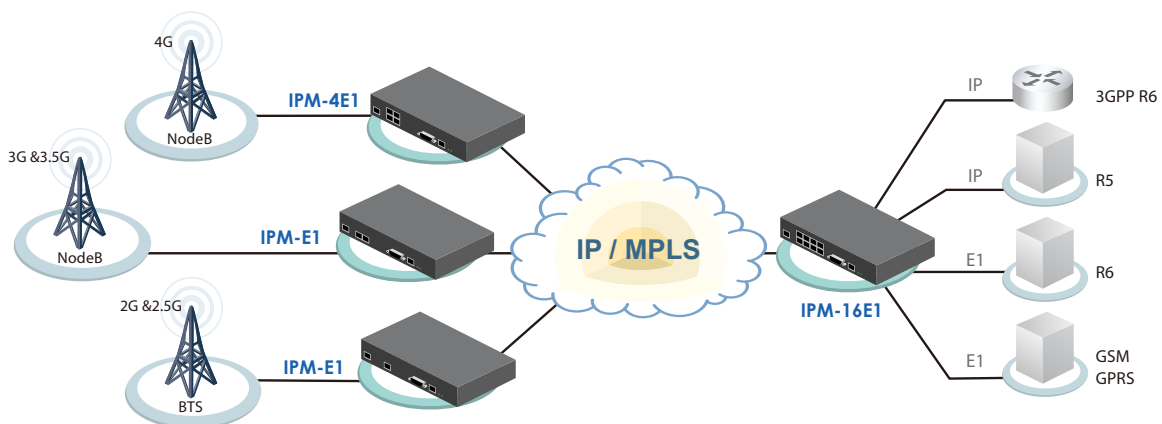

Ordering Information

Model Name	Description
IPM-8E1-AD	8E1 over Ethernet with built-in AC+DC Power
IPM-16E1-AD	16E1 over Ethernet with built-in AC+DC Power

Port Number Power Type
IPM - **-**
 Example: IPM - 16E1 - AD



STE100A-232

RS232 Serial Server

STE100A-Serial

RS485/232 Serial Server

The IP Device Server provides the serial device server for hosts to control RS-232, 2 or 4 wire asynchronous RS-422/485 serial devices located virtually anywhere through a TCP/IP or UDP/IP connection. The Device Server has the DB9 port connection on one side, and a 10/100 Mbps Ethernet connection on the other side. It connects serial devices such as PLC, alarm sensors and PTZ camera control to IP networks. Applications include industrial/factory automation, public safety and surveillance systems. The IP Device Server Windows driver is designed to control the IP Serial Server devices. The driver installs a virtual COM on Windows which maps the virtual COM port to the IP address of the IP Serial Server device across the network, enabling the Windows applications to access remote serial devices over Ethernet. IP Device Server can function as a UDP or a server or client for TCP connection. The application scenarios are direct IP mode, virtual COM mode, and paired mode.

Feature

- Supports Web Management
- Supports IETF RFC4553 Structure-Agnostic TDM over Packet (SAToP), Metro Ethernet Forum MEF8
- 8 /16 x E1 NRZ Serial Interface with LOS/AIS detection
- Use Raw Encapsulation method for PDH payload over IP packet
- Supports Circuit Emulation Service over IPE
- Comply with IETF draft standard for CESoPSN and SAToP; Metro Ethernet Forum MEF8 IA
- Supports both Point-to-Point and Point-to-Multipoint operation
- Configurable IEEE 802.3 DA/SA assignment
- Supports 8/16 independent Adaptive Clock recovery block for Ingress PDH (PSN->TDM) clock generation. Recovered clock jitter is compliant with ITU-T G.823 (E1 Jitter Control)
- Independent configurable jitter buffer depth to compensate up to 250ms of Packet Delay Variation
- Lost packets processing / compensation via PW (Pseudo Wire) control field Sequence Number
- PDH LOS detection triggered PW L field or payload AIS generation at Egress direction (TDM->PSN)
- LED alarm display for E1 Power failure status

Specifications

General	LED	Ready, TP Link/Act, Data TX/RX
	OS supported	Windows XP / 2000 / 2003 / 2008 / VISTA / WIN7 / WIN8
Serial Interface	STE100A-Serial I : RS-232/422/485 STE100A-232 : RS-232	
Serial Connector	DB9 Male	
Baudrate	110 to 230.4Kbps	
Data bits	5, 6, 7, 8	
Stop bits	1, 1.5 for Data bits 5 mode; 1, 2 for data bits 6, 7, 8 mode	
Parity	None, Even, Odd	
Flow Control	None or RTS / CTS for RS-232 Full Duplex(4-Wire) or Half Duplex(2-Wire) for RS-422/485	
Data Packing Delimiter	1,2	

LAN Interface	RJ-45 connector, IEEE802.3 10/100Base-TX
Communication Modes	TCP Server, TCP Client, Virtual COM mode, UDP
Protocols	TCP, UDP, IP, ARP, ICMP, HTTP, DHCP
Management	Web pages, Firmware upgrade
Security	Password Access
Power	12VDC
Operating Temperature	0 ~ 60°C
Storage Temperature	-10 ~ 70°C
Humidity	0 – 90% non-condensing
DIN rail mount	Yes
Panel mount	Yes
Dimensions	85.8 x 84.2 x 22mm (D x W x H) with DIN-Rail Mounting Kit
Certifications	CE, FCC

Application

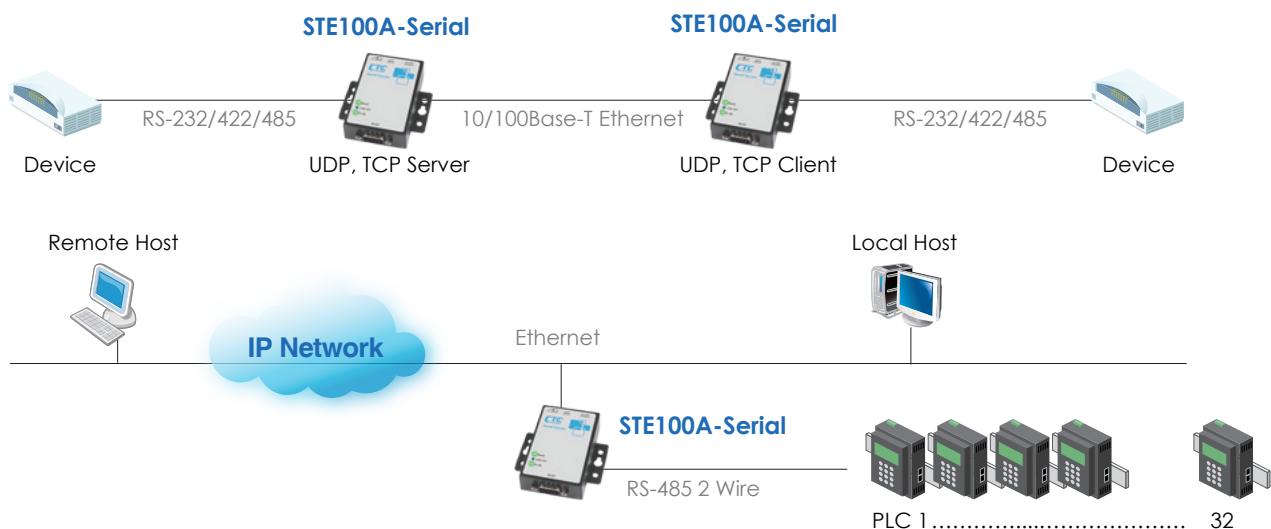

Appearance



Dimensions

STE100A-232

Unit: mm (inch)

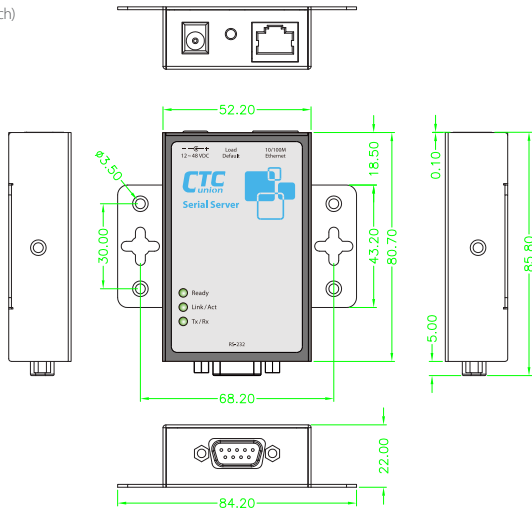

STE100A-Serial

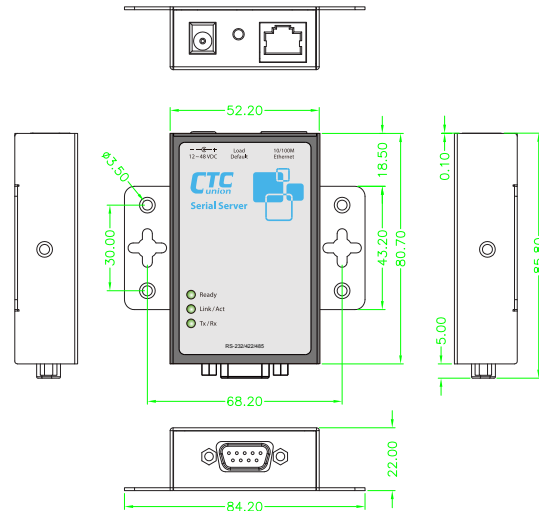

Ordering Information

Model Name	Description
STE100A-232	1-port RS232 device server with AC power adapter
STE100A-Serial	1-port RS232/422/485 device server with AC power adapter
Optional accessories	
STE100A-Serial-WT	STE100A-Serial DB9 wiring terminal
STE100A/DRK01	STE100A/RS232,STE100A/Serial DIN-Rail Mounting Kit
Optional Power	
DC-APT/12V	-48VDC to 12VDC Adapter - 0.83 Amp, 10 Watts , Output 12VDC, Input -48VDC



Appendix

- FRM220 Standalone Selection Table

Model Name	Slot	NMC Card Slot	Console Port	Adapter Type	Power Built-In Type			Cooling Fan	Fan-less	Power Module
				100~240VAC to 12VDC	100~240VAC	18~72VDC	Dual Power 100~240VAC & 18~72VDC			
CH01	1			✓					✓	12W
CH01-AC	1				✓				✓	12W
CH01-DC	1					✓			✓	12W
CH01-AD	1						✓		✓	12W/12W
CH01M-AC	1		✓		✓				✓	12W
CH01M-DC	1		✓			✓			✓	12W
CH01M-AD	1		✓				✓		✓	12W/12W
CH02	2			✓					✓	30W
CH02M-AC	2		✓		✓			✓		30W
CH02M-DC	2		✓			✓		✓		30W
CH02M-AD	2		✓				✓	✓		30W/30W
CH02M-2-AC	2		✓		✓				✓	12W
CH02M-2-DC	2		✓			✓			✓	12W
CH02M-2-AD	2		✓				✓		✓	12W/12W
CH02/NMC-AC	2	✓			✓			✓		30W
CH02/NMC-DC	2	✓				✓		✓		30W
CH02/NMC-AD	2	✓					✓	✓		30W/30W
CH04A-AC	4	✓			✓			✓		65W
CH04A-DC	4	✓				✓		✓		50W
CH04A-AD	4	✓					✓	✓		65W/50W

How to order

- DIP Switch Configuration Order : CH01 and CH02
- Local Console Management Order : CH01M, CH02M and CH02M-2. "M" means the chassis with Console Management.
- Remote Web / SNMP Management Order : CH02 / NMC, CH04A
- Power Type : AD = AC + DC Power

Appendix

- Slide-in Card vs Standalone Chassis Compatible Table

Card Name	Product Name	Page	FRM220-CH20	CH08	CH04A	CH02/NMC
FRM220-NMC	Network Management Controller	2-?	✓	✓	✓	✓
FRM220-40G-1Q4S	40G QSFP to 4x10G SFP+ Transponder	2-?	✓	✓	✓	✓
FRM220-16G-3R	16G Multi Rate Transponder (3R)	2-?	✓	✓	✓	✓
FRM220-10G-FEC	SFP+ STM-64/10G Ethernet FEC Transponder	2-?	✓	✓	✓	✓
FRM220-10G-SXX	10G 3R Transponder SFP+ to XFP Fiber Protection	2-?	✓	✓	✓	✓
FRM220-10G-SS	10G 3R Transponder SFP+ to SFP+	2-?	✓	✓	✓	✓
FRM220-4G-3S	4G Multi-Rate 2R Transponder SFP to SFP Fiber Protection	2-?	✓	✓	✓	✓
FRM220-2.7G-3S	2.7G Multi-Rate 3R Transponder SFP to SFP Fiber Protection	2-?	✓	✓	✓	✓
FRM220-OAB15	Single Channel EDFA Booster NIC	2-?	✓	✓	✓	✓
FRM220-DWDM	DWDM Mux/DeMux	2-?	✓	✓	✓	
FRM220-CWDM	CWDM Mux/DeMux	2-?	✓	✓	✓	
FRM220-OP52	Fiber Optical Protection Switch	2-?	✓	✓	✓	✓
FRM220-OP51	Fiber Optical Protection Switch	2-?	✓	✓	✓	✓
FRM220-10GC-TS	10G Ethernet Converter 10G Base-T to SFP+	2-?	✓	✓	✓	✓
FRM220-MSW404	4x GbE, RJ45 + 4x Dual Rate L2+ OAM Managed Switch	2-?				
FRM220-MSW202	2x GbE, RJ45 + 2x Dual Rate L2+ OAM Managed Switch	2-?	✓	✓	✓	
FRM220-MX210	2-Port Gigabit Ethernet Multiplexer	2-?	✓	✓	✓	✓
FRM220A-1002ES	2x 10/100/1000Base-T + 2x 100/1000Base-X SFP GbE Switch	2-?	✓	✓	✓	✓
FRM220A-1000EAS/X	2-Port 10/100/1000Base-T + 2-Port 1000Base-X OAM/IP Managed Switch	2-?	✓	✓	✓	✓
FRM220-10/100	10/100Base-TX to 100Base-FX Media Converter	2-?	✓	✓	✓	
FRM220-1000DS	1000Base-X to 1000Base-X SFP media converter	2-?	✓	✓	✓	✓
FRM220-1000TS	1000Base-T to 1000Base-X SFP Media Converter	2-?	✓	✓	✓	✓
FRM220-1000M	10/100/1000Base-T to 1000Base-X Web Smart OAM/IP Managed Converter	2-?	✓	✓	✓	✓
FRM220-1000MS	10/100/1000Base-T to 100/1000Base-X SFP Web Smart OAM/IP Managed Converter	2-?	✓	✓	✓	✓
FRM220-1000EAS/X-1	OAM/IP-Based Managed Gigabit Ethernet Media Converter	2-?	✓	✓	✓	✓
FRM220-100EAS/X-1	10/100Base-TX to 100Base-FX Media Converter	2-?	✓	✓	✓	
FRM220-10/100i	10/100Base-TX to 100Base-FX In-band Managed Converter	2-?	✓	✓	✓	✓
FRM220-10/100iS-2	Dual Channels 10/100Base-TX to 100Base-FX In-Band Managed Converter	2-?	✓	✓	✓	✓
FRM220-FXO-4&FXS-4	4x POTS over Fiber	2-?	✓	✓	✓	✓
FRM220-FXO/FXS	POTS over Fiber	2-?	✓	✓	✓	✓
FRM220A-iMux16	Ethernet to 16 E1 Mux NIC	2-?	✓	✓	✓	✓
FRM220A-iMux8	Ethernet to 8 E1 Mux NIC	2-?	✓	✓	✓	✓
FRM220A-iMux4	Ethernet to 4 E1 Mux NIC	2-?	✓	✓	✓	✓
FRM220-GFOM08	8-Port E1/T1+10/100/1000M Ethernet Fiber Multiplexer	2-?	✓	✓	✓	
FRM220-GFOM04	4-Port E1/T1+10/100/1000M Ethernet Fiber Multiplexer	2-?	✓	✓	✓	✓
FRM220-FOM04	4-Port E1/T1+100M Ethernet Fiber Multiplexer	2-?	✓	✓	✓	✓
FRM220-FOM01	E1/T1+100M Ethernet Fiber Multiplexer	2-?	✓	✓	✓	✓
FRM220-DS3/E3	DS3/E3 over Fiber	2-?	✓	✓	✓	✓
FRM220-Serial	RS485/232 Media Converter	2-?	✓	✓	✓	✓
FRM220-FTEC	E1/T1 Cross Rate Converter	2-?	✓	✓	✓	✓
FRM220-E1/Data	E1 to Data	2-?	✓	✓	✓	✓
FRM220A-Eoe1	Ethernet Bridge over E1	2-?	✓	✓	✓	✓
FRM220-E1/T1	E1/T1 Fiber Modem	2-?	✓	✓	✓	✓
FRM220-Data	V.35/X.21/RS530/449/232 Fiber Modem	2-?	✓	✓	✓	✓
FRM220-ET100	Ethernet over E1 Fiber Modem	2-?	✓	✓	✓	✓

- Power Type vs Standalone Chassis Compatible Table

Power Type (option)	AC: AC Power	DC: DC Power	AC, DC	AC, DC	AC, DC
	AD: AC+DC Power	AA: AC+AC Power	AD, AA, DD	AD, AA, DD	AD, AA, DD
		DD: DC+DC Power			

Appendix

- Slide-in Card vs Standalone Chassis Compatible Table

Card Name	Product Name	Page	CH02M	CH02M-2	CH02	CH01M	CH01
FRM220-NMC	Network Management Controller	2-?					
FRM220-40G-1Q4S	Gigabit Ethernet Aggregate Switch Card	2-?	✓				
FRM220-16G-3R	16G Multi Rate Transponder (3R)	2-?	✓			✓	✓
FRM220-10GFEC	10G 3R Transponder SFP+ to XFP Fiber Protection	2-?	✓				
FRM220-10G-SXX	10G 3R Transponder SFP+ to SFP+	2-?	✓				
FRM220-10G-SS	4G Multi-Rate 2R Transponder SFP to SFP Fiber Protection	2-?	✓				
FRM220-4G-3S	2.7G Multi-Rate 3R Transponder SFP to SFP Fiber Protection	2-?	✓			✓	
FRM220-2.7G-3S	1000Base-X to 1000Base-X SFP media converter	2-?	✓				
FRM220-OAB15	10G Ethernet Converter 10G Base-T to SFP+	2-?	✓				
FRM220-DWDM	10G Ethernet Converter 10G Base-T to XFP	2-?			✓		✓
FRM220-CWDM	4 and 8-ch DWDM Mux/DeMux	2-?			✓		✓
FRM220-OP52	4 and 8-ch CWDM Mux/DeMux	2-?				✓	✓
FRM220-OP51	Optical Add-Drop Multiplexer	2-?				✓	✓
FRM220-10GC-TS	1+1 Fiber Optical Protection Switch	2-?	✓				
FRM220-MSW404	2x 10/100/1000Base-T + 2x 100/1000Base-X SFP GbE Switch	2-?	✓				
FRM220-MSW202	3x10/100Base-TX + 1x100Base-FX SFP Switch	2-?	✓			✓	✓
FRM220-MX210	2-Port 10/100/1000Base-T + 2-Port 1000Base-X OAM/IP Managed Switch	2-?				✓	✓
FRM220A-1002ES	2x GbE, RJ45 + 2x Dual Rate L2+ OAM Managed Switch	2-?				✓	✓
FRM220A-1000EAS/X	4x GbE, RJ45 + 4x Dual Rate L2+ OAM Managed Switch	2-?				✓	✓
FRM220-10/100	2-Port Gigabit Ethernet Muxponder	2-?					✓
FRM220-1000DS	10/100Base-TX to 100Base-FX Media Converter	2-?	✓				✓
FRM220-1000TS	1000Base-T to 1000Base-X SFP Media Converter	2-?					✓
FRM220-1000M	10/100/1000Base-T to 1000Base-X Web Smart OAM/IP Managed Converter	2-?				✓	✓
FRM220-1000MS	10/100/1000Base-T to 100/1000Base-X SFP Web Smart OAM/IP Managed Converter	2-?				✓	✓
FRM220-1000EAS/X-1	10/100/1000Base-T to 100/1000Base-X SFP OAM/IP GbE Media Converter	2-?				✓	✓
FRM220-100EAS/X-1	10/100Base-TX to 100Base-FX Media Converter	2-?				✓	✓
FRM220-10/100i	10/100Base-TX to 100Base-FX In-band Managed Converter	2-?				✓	✓
FRM220-10/100iS-2	10/100Base-TX to 100Base-FX SFP In-band Managed Converter	2-?				✓	✓
FRM220-FXO-4&FXS-4	E1/T1 Fiber Modem	2-?				✓	✓
FRM220-FXO/FXS	V.35/X.21/RS530/449/232 Fiber Modem	2-?				✓	✓
FRM220A-iMux16	Ethernet over E1 Fiber Modem	2-?	✓	✓			
FRM220A-iMux8	DS3/E3 over Fiber	2-?				✓	
FRM220A-iMux4	RS485/232 Media Converter	2-?				✓	
FRM220-GFOM08	4xPOTS over Fiber	2-?	✓	✓			
FRM220-GFOM04	POTS over Fiber	2-?	✓	✓			
FRM220-FOM04	Ethernet Bridge over E1	2-?	✓	✓	✓		
FRM220-FOM01	Ethernet Bridge over E1 (GFP)	2-?				✓	
FRM220-DS3/E3	Ethernet to 16 E1 Mux NIC	2-?				✓	✓
FRM220-Serial	Ethernet to 8 E1 Mux NIC	2-?				✓	✓
FRM220-FTEC	Ethernet to 4 E1 Mux NIC	2-?				✓	
FRM220-E1/Data	8-Port E1/T1+10/100/1000M Ethernet Fiber Multiplexer	2-?				✓	
FRM220A-Eoe1	4-Port E1/T1+10/100/1000M Ethernet Fiber Multiplexer	2-?				✓	
FRM220-E1/T1	4-Port E1/T1+100M Ethernet Fiber Multiplexer	2-?				✓	✓
FRM220-Data	E1/T1+100M Ethernet Fiber Multiplexer	2-?				✓	✓
FRM220-ET100	E1/T1 Cross Rate Converter	2-?				✓	✓

- Power Type vs Standalone Chassis Compatible Table

Power Type (option)	DC12: AC Adapter AD: AC+DC Power	AC: AC Power AA: AC+AC Power	DC: DC Power DD: DC+DC Power	AC, DC, AD	AC, DC, AD	DC12	DC12, AC, DC, AD, AA, DD	AC, DC, AD
---------------------	-------------------------------------	---------------------------------	---------------------------------	---------------	---------------	------	-----------------------------	---------------